

premium rotary instruments

Zahnmedizin/Zahntechnik
Dentistry/Dental Technique
Odontologie/Prothese Dentaire
Odontologie/Protesis Dental





Inhalt



Index



Index



Indice



Push®

There is no substitute for quality

Zahnmedizin • Dentistry
Odontologie • Odontologia

Zahntechnik • Dental Technology
Prothese Dentaire • Protesis Dental

Diamant

Diamond
Diamant
Diamante

4-35



78-95

**Hartmetall**

Carbide
Carbure
Carburo

36-55



96-123

**Keramik**

Ceramic
C eramique
Cer mica

124-127

**Stahl**

Steel
Acier
Acero

56-61



128-137

**Polierer**

Polishers
Polissoirs
Pulidores

62-73



138-149

**Schleifk rper**

Abrasives
Abrasifs
Abrasivos

74-77



150-161

**Set, Bohrerst nder, Sonstiges**

Set, Bur bloc, Miscellaneous
Set, Porte-fraises, Autres
Set, Fresero, Otros

162-173

**Basisinformationen**

Basic information
Informations de base
Informaciones b sicas

174-187

**Inhaltsverzeichnis**

Index
Index
 ndice

188-192

Inhaltsverzeichnis nach USA-Nr.

Index according to US-No.
Index par num ro US
 ndice por n meros US

193



Christian Rothe

Gert Busch

There is no substitute for quality

„Qualität hat keine Alternative“ – diese Überzeugung prägt seit Gründung des Unternehmens im Jahre 1905 unsere Unternehmensphilosophie.

Unsere Innovationen und alle Prozesse der Entwicklung, Produktion und des Vertriebs folgen dieser Philosophie.

„There is no substitute for quality“ this conviction has committed our company's philosophy since the foundation in 1905.

Our innovations and all processes of research & development, production and distribution meet with the demands of this philosophy.

„Il n'y a pas d'alternative à la qualité“ c'est bien notre conviction depuis la création de la société Busch en 1905.

Nos innovations ainsi que tous les processus du développement, de la production et de la vente correspondent à cette philosophie.

„Calidad no tiene alternativa“ – Esta convicción caracteriza nuestra filosofía desde la fundación en 1905.

Nuestras innovaciones y todos los procesos en el desarrollo, en la producción y en la distribución siguen esta filosofía.

Zahnmedizin













Dentistry • Odontologie • Odontologia

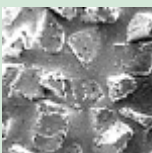



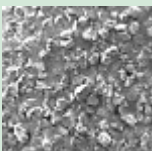

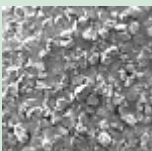



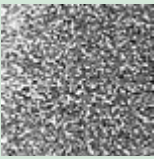

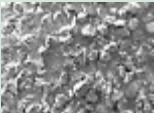





Diamant

Diamond • Diamant • Diamante

Anwendungsbeispiele Examples of application Exemples d'application Ejemplos de aplicaciones	6+7
COOL DIAMANT	8-13
Premium Diamantschleifer Premium diamond instruments Instruments diamantés supérieurs Instrumentos diamantados superiores	14-31
Micro Prep	32+33
ZIRAMANT	34
Dia PERIO-PRO	35

Einsatzgebiet application area domaine d'application uso en sector	Arbeitsgang working process phase de travail fase de trabajo	Körnung R.E.M. (30x) grit D.S.M. (30x) grain M.E.B. (30x) grano M.E.R. (30x)	Instrumentenbeispiel examples of instr. exempl. d'instruments ej. de los instrumentos	ISO-Ø	empf. Drehzahl min ⁻¹ recommended speed vit. de rotation rec. veloc. recomendada
Schmelz, Dentin enamel, dentine email, dentine esmalte, dentina	Zügiges Vorschleifen faster pregrinding dégrossissage rapide rectificado inicial rápido		5831/014 	012 – 023	225.000 – 60.000
Schmelz, Dentin enamel, dentine email, dentine esmalte, dentina	vorschleifen pregrinding dégrossissage rectificado inicial		CD72G/014 	010 – 023	225.000 – 60.000
			6831/014 		
Schmelz, Dentin enamel, dentine email, dentine esmalte, dentina	Formschleifen shape grinding façonnage rectificado de forma		CD34/012 	010 – 023	225.000 – 60.000
Schmelz, Dentin, Füllungen enamel, dentine, fillings email, dentine, obturations esmalte, dentina, obturaciones			CD80/023 		
Schmelz, Dentin enamel, dentine email, dentine esmalte, dentina			831/012 		
Schmelz, Dentin, Füllungen enamel, dentine, fillings email, dentine, obturations esmalte, dentina, obturaciones	Feinschleifen fine grinding abrasion de précision rectificado fino		859/010 	008 – 055	225.000 – 35.000
Schmelz, Dentin, Füllungen enamel, dentine, fillings email, dentine, obturations esmalte, dentina, obturaciones			CD72F/014 		
Schmelz, Dentin, Füllungen enamel, dentine, fillings email, dentine, obturations esmalte, dentina, obturaciones	Feinschleifen fine grinding abrasion de précision rectificado fino		8801/023 	007 – 031	100.000 – 20.000

Einsatzgebiet application area domaine d'application uso en sector	Arbeitsgang working process phase de travail fase de trabajo	Körnung R.E.M. (30x) grit D.S.M. (30x) grain M.E.B. (30x) grano M.E.R. (30x)	Instrumentenbeispiel examples of instr. exempl. d'instruments ej. de los instrumentos	ISO-Ø	empf. Drehzahl min ⁻¹ recommended speed vit. de rotation rec. veloc. recomendada
Schmelz, Dentin, Füllungen enamel, dentine, fillings email, dentine, obturations esmalte, dentina, obturaciones	Finieren finishing finissage acabado		862EF/012 	007 – 029	100.000 – 20.000
Schmelz, Dentin (für Ceramic Inlays) enamel, dentine (for ceramic inlays) email, dentine (pour inlays en céramique) esmalte, dentina (para ceramic inlays)			CI847EF/018 		
Dia PERIO-PRO					
Zahnstein calculus plaque dentaire cálculo	Entfernen removal retrait retracción		8406LF/012 	012	12.000
Wurzelzement root cementum ciment radicaire cemento de raices	Glätten polishing lissage alisado		8407LEF/012 	012	8.000
Micro Prep					
Schmelz, Dentin enamel, dentine email, dentine esmalte, dentina	minimal invasiv minimum contact invasive minimale invasiva minimal	 	MI806 	007 – 014	150.000 – 120.000
			MI8806 	007 – 014	120.000 – 100.000
ZIRAMANT					
Zirkonoxid zirconia oxyde de zirconium óxido de zirconio	Trepanieren/Entfernen trepanation/removal trépanation/retrait trepanación/retracción		6880Z/014 	010 – 018	160.000 – 140.000
	Korrektur von Abutments correction of abutments correction de piliers retoque de pilares		862Z/016 	014 – 016	
	Feinkorrektur fine correction correction de précision retoques precisos		8838LZ/009 	009 – 011	

COOL DIAMANT

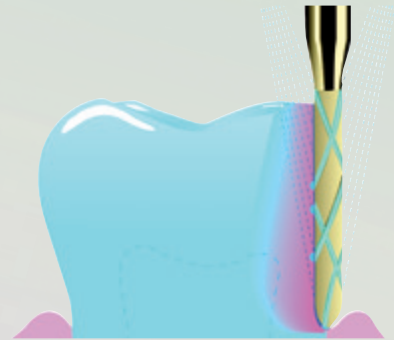

cool

Die Oberfläche der COOL DIAMANT-Schleifer ist durch asymmetrisch sich kreuzende Kanäle unterbrochen. Diese diamantierten Kanäle können zum einen eine erhöhte Menge Kühlflüssigkeit transportieren und unterbrechen zum anderen den Schleifvorgang bis zu 7 mal bei jeder Umdrehung des Schleifers. Beides fördert einen kühlen Schliff.

Asymmetrically intersecting grooves break up the surface of the COOL DIAMANT instruments. These diamond-coated grooves not only transport more cooling medium, but also interrupt the grinding process up to seven times during each rotation of the instrument. These two factors ensure a cool process.

La surface des instruments COOL DIAMANT est sillonnée de canaux qui se croisent selon une structure asymétrique. Ces canaux diamantés sont capables non seulement d'évacuer une quantité plus importante de liquide de refroidissement, mais aussi d'interrompre le meulage jusqu'à sept fois par rotation, deux atouts qui garantissent une abrasion "cool".

La superficie de los instrumentos COOL DIAMANT está demarcada por canales que se cruzan de forma asimétrica. Estos canales diamantados pueden transportar una cantidad de líquido refrigerante relativamente elevada y al mismo tiempo interrumpen el proceso de pulido hasta 7 veces en cada vuelta del instrumento. Ambas características aseguran un pulido "cool".

schnell

**fast
gain de temps
rápido**

Bei umfangreichen prothetischen Präparationsaufgaben ergaben sich bei Einsatz von COOL DIAMANT-Schleifern bereits mit mittlerer Körnung deutliche Zeiteinsparungen. Die original COOL DIAMANT-Schleifer sind zur schnelleren Identifikation in allen drei Körnungen golden.

Extensive prosthetic preparations using COOL DIAMANT instruments in medium grit, turn out to show a considerable saving in time. The original COOL DIAMANT instruments are golden in all three grits for a faster identification.

Pour les préparations prothétiques importantes l'utilisation des COOL DIAMANT grain moyen apporte un gain de temps. Pour une identification rapide, les originaux COOL DIAMANT en 3 différents grains sont tous dorés.

Utilizando instrumentos diamantados COOL DIAMANT de grano medio en numerosas preparaciones protéticas, se han logrado ahorros de tiempo significante. Los instrumentos diamantados originales COOL DIAMANT son dorados en los tres tamaños de grano, para una identificación más rápida.

wirtschaftlich

**economical
économique
económico**

Der hochwertige Diamantbelag mit Panzerschutzschicht, die gleichmäßige stabilitätserhöhende Diamantierung auch in den Kanälen und ständige Fertigungskontrollen garantieren die überlegene BUSCH-Qualität. Der reduzierte Zeitbedarf sowie die Langlebigkeit der COOL DIAMANT-Schleifer ermöglichen wirtschaftliche und zugleich patientenfreundliche Präparationen.

The high-grade diamond coating with armour-protective layer, the consistent stability of the diamond coating also in the cooling grooves and constant controls guarantee the top-class quality of BUSCH instruments. The time-saving as well as the longevity of the COOL DIAMANT instruments make economical and patient-friendly preparations.

La couche diamantée de haute qualité avec protection, le revêtement diamanté symétrique des rainures de refroidissement offrent une stabilité accrue et les contrôles de fabrication constants garantissent la qualité supérieure BUSCH. Le gain de temps et la longévité des COOL DIAMANT permettent des préparations économiques et agréables pour les patients.

El recubrimiento diamantado de alta calidad con capa de protección, el diamantado uniforme, que aumenta la estabilidad también en el interior de los canales de refrigeración, y los continuos controles de fabricación garantizan la superior calidad de BUSCH. El ahorro de tiempo necesario, así como la larga vida útil de los instrumentos diamantados COOL DIAMANT, permiten realizar preparaciones más económicas y al mismo tiempo más agradables para el paciente.

drei Körnungen

**3 grits
3 grains
3 tamaños de grano**

Funktions- und formkongruente Instrumente in drei Körnungen für präzise aufeinander abgestimmte Präparationsschritte.

Congruent instruments in function and shape in three grits for precise coordinating steps in the preparation.

Les instruments d'une congruence de forme et fonction en 3 grains pour une coordination précise des phases de préparations.

Instrumentos congruentes en función y forma, en tres tamaños de grano, para fases de preparación exactamente adaptadas.

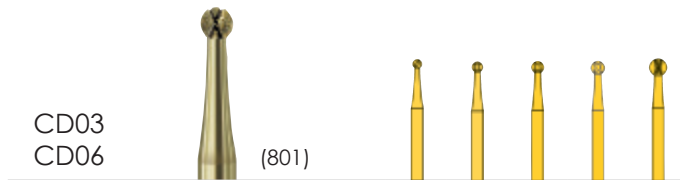

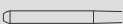
	CD03/...	012				
FG	CD06/...		014	016	018	023

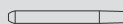

	CD09/...	012			
FG	CD12/...		016	018	
FG	CD15/...				016
L mm		1,5	1,7	1,8	4,0

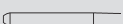

	CD18G/...	012		
● FG	CD18/...	012	014	016
L mm		2,7	2,7	2,7



	CD19G/...	014	016	
● FG	CD19/...	014	016	018
L mm		5,0	5,0	5,0

● grobe Körnung, coarse grit, gros grain, grano grueso
mittlere Körnung, medium grit, grain moyen, grano mediano } 

● feine Körnung, fine grit, grain fin, grano fino } 

CD63 (876)

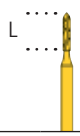
FG

CD63/...	010
L mm	5,0

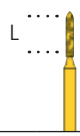

CD66G
CD66
CD66F (877)

FG

CD66G/...	010			
FG	CD66/...	010	012	014
FG	CD66F/...	010		
L mm		6,0	6,0	6,0



CD69G
CD69
CD69F (878)

FG

CD69G/...	012	014	016	
FG	CD69/...	012	014	016
FG	CD69F/...		014	
L mm		8,0	8,0	8,0

CD72G
CD72
CD72F (879)

FG

CD72G/...	012*	014	016	
FG	CD72/...	012*	014	016
FG	CD72F/...	012*	014	016
L mm		10,0	10,0	10,0

*Drehzahlempfehlung/recommended speed/vitesse recommandée/velocidad recomendada CD72, CD72G, CD72F 012 110.000-150.000 min⁻¹/r.p.m.



	● FG	CD27G/...	010		
	FG	CD27/...	010	012	
L mm			4,0	4,0	



	● FG	CD30G/...		012	014
	FG	CD30/...	010	012	014
L mm			6,0	6,0	6,0

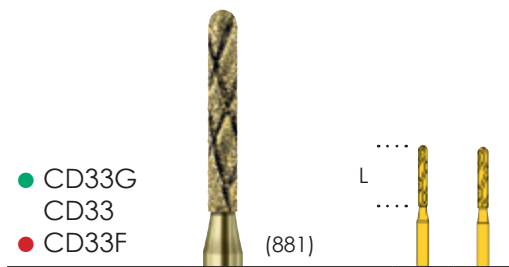

	● FG	CD33G/...	012	014	
	FG	CD33/...	012	014	
	● FG	CD33F/...	012		
L mm			8,0	8,0	

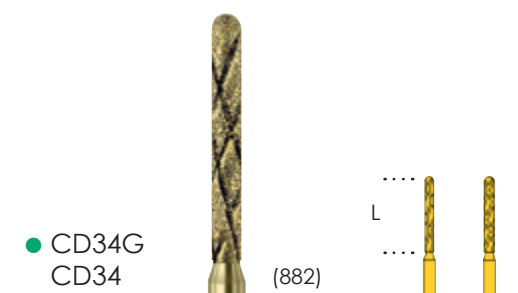

	● FG	CD34G/...	012*	014	
	FG	CD34/...	012*	014	
L mm			10,0	10,0	

*Drehzahlempfehlung/recommended speed/vitesse recommandée/velocidad recomendada CD34, CD34G 012 110.000-150.000 min⁻¹/r.p.m.

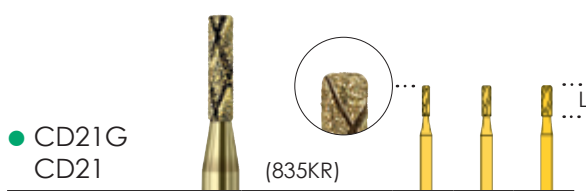

	● FG	CD21G/...	010	012	014
	FG	CD21/...	010	012	014
L mm			4,0	4,0	4,0

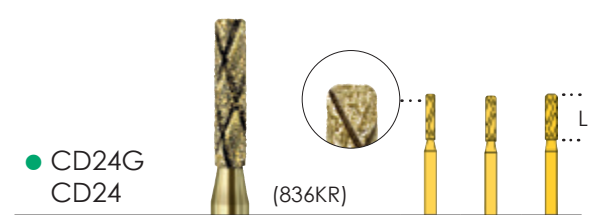

	● FG	CD24G/...	012	014	
	FG	CD24/...	012	014	016
L mm			6,0	6,0	6,0

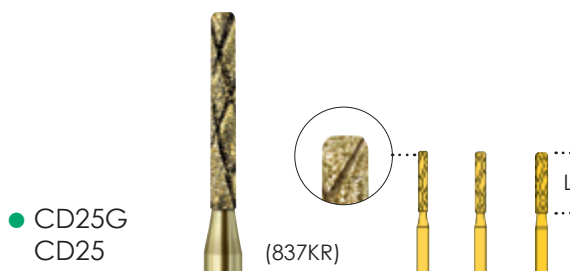

	● FG	CD25G/...	012	014	
	FG	CD25/...	012	014	016
L mm			8,0	8,0	8,0

● grobe Körnung, coarse grit, gros grain, grano grueso }

● mittlere Körnung, medium grit, grain moyen, grano mediano }

● feine Körnung, fine grit, grain fin, grano fino }

CD36 (845KR)

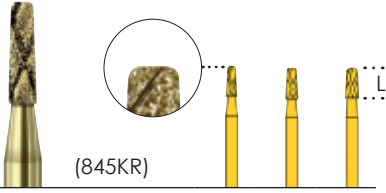

FG

CD36/...	014	016	018
L mm	4,0	4,0	4,0

CD37 (846KR)

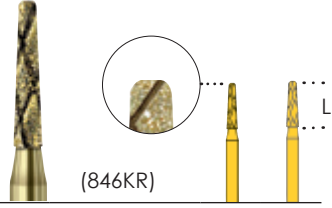

FG

CD37/...	014	016
L mm	6,0	6,0

● CD39G
CD39 (847KR)

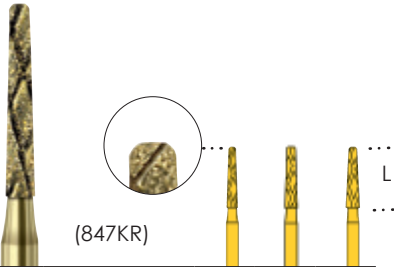

FG

CD39G/...		016		
FG	CD39/...	014	016	018
L mm		8,0	8,0	8,0

● CD42G
CD42 (848KR)

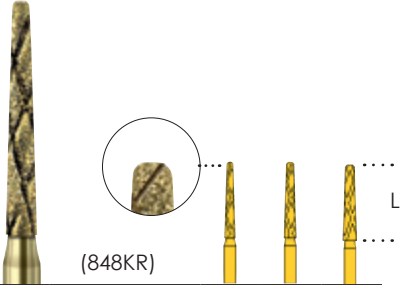

FG

CD42G/...		016	018	
FG	CD42/...	014	016	018
L mm		10,0	10,0	10,0

CD45 (855)

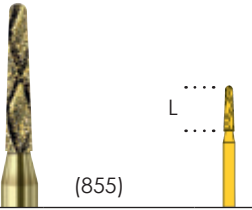

FG

CD45/...	014
L mm	6,0

● CD48G
CD48 (856)

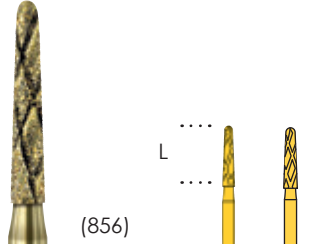

FG

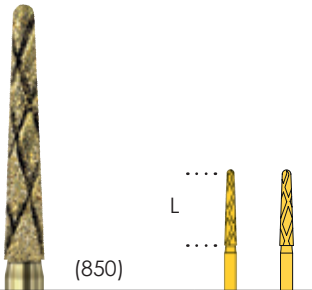

CD48G/...	016	018	
FG	CD48/...	016	
L mm		8,0	8,0

● CD51G
CD51 (850)



FG

CD51G/...	016	018	
FG	CD51/...	016	018
L mm		10,0	10,0

● grobe Körnung, coarse grit, gros grain, grano grueso
 ● mittlere Körnung, medium grit, grain moyen, grano mediano } 
 ● feine Körnung, fine grit, grain fin, grano fino } 

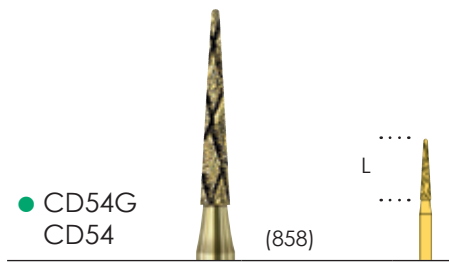

	CD54G/...	014
● FG	CD54/...	014
L mm		8,0

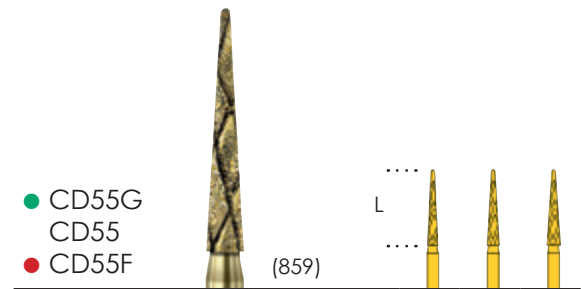

	CD55G/...	014	016	018
● FG	CD55/...	014	016	018
● FG	CD55F/...	014		
L mm		10,0	10,0	10,0



	CD57/...	012	016
FG			
L mm		5,0	5,0



	CD60G/...		014	
● FG	CD60/...	012	014	016
● FG	CD60F/...	012		016
L mm		8,0	8,0	8,0



	CD61G/...	012	016
● FG	CD61/...	012	016
● FG	CD61F/...	012	016
L mm		10,0	10,0



	CD80G/...		023
● FG	CD80/...	016	023
● FG	CD80F/...		023
L mm		3,5	5,0

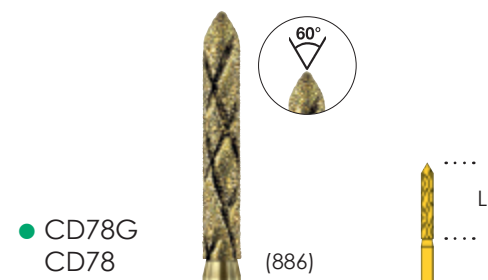

	CD78G/...	016
● FG	CD78/...	016
L mm		10,0

● grobe Körnung, coarse grit, gros grain, grano grueso
● mittlere Körnung, medium grit, grain moyen, grano mediano }

● feine Körnung, fine grit, grain fin, grano fino }

Premium Diamantschleifer

Premium diamond instruments • Instruments diamantés supérieurs • Instrumentos diamantados superiores



Premium Diamantschleifer

Für Ihre anspruchsvolle Patienten-Behandlung.

Mit unseren Premium Diamantschleifern sichern Sie sich höchste Präzision, Effektivität und Leistungsstärke. Modernste Fertigungsanlagen und beste Materialien schaffen diesen hohen Qualitäts-Standard. Produktsicherheit für alle vorkommenden Präparationschritte.

Premium diamond instruments

For your challenging tasks in patient treatment.

With our premium diamond instruments, you can enjoy utmost precision, effectiveness and performance.

An outstanding quality like this can only be achieved with the most advanced production facilities and the finest materials.

Instruments diamantés supérieurs

Pour offrir le meilleur traitement à vos patients.

Avec les instruments diamantés premium, vous êtes certain d'avoir ce qu'il y a de mieux en termes de précision, d'efficacité et de performances. Un standard de qualité obtenu grâce à des équipements de fabrication ultramodernes et à des matériaux de qualité supérieure. Un produit qui offre une sécurité absolue pour toutes les étapes de la préparation.

Instrumentos diamantados superiores

Para el tratamiento de pacientes exigentes.

Con los instrumentos diamantados premium se asegura la máxima precisión, efectividad y productividad.

Este elevado estándar de calidad se debe a las más modernas instalaciones de fabricación y los mejores materiales. Seguridad de producto para todos los posibles pasos de preparación.

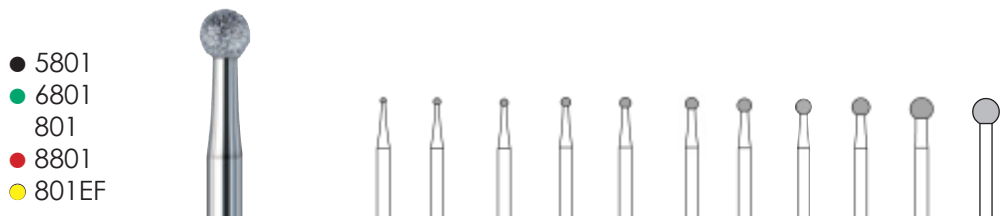

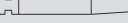
 ● FG ISO 806 314 001 544...	5801/...					014	016	018		023		
● FG ISO 806 314 001 534...	6801/...			010	012	014	016	018	021	023	029	
FG ISO 806 314 001 524...	801/...		009	010	012 ***	014 ***	016 ***	018 ***	021	023 ***	029	035
● FG ISO 806 314 001 514...	8801/...	007				014	016	018		023	029	035
● FG ISO 806 314 001 504...	801EF/...	007				014		018		023	029	
 W/RA/CA ISO 806 204 001 524...	801/...									*023		



● FG ISO 806 314 697 534...	6801L/...	016
FG ISO 806 314 697 524...	801L/...	016



● FG ISO 806 314 002 534...	6802/...	010	012	014	
FG ISO 806 314 002 524...	802/...	010	012	014	018
L mm		2,6	2,6	2,6	2,6

*801 W/RA/CA = 

*** auch als COOL-Diamant-Schleifer lieferbar (siehe Seiten 9-13)
 also available as COOL-Diamond Instruments (see pages 9-13)
 Egalement disponible en instruments COOL Diamonds (voir pages 9-13)
 También disponible como instrumentos COOL Diamonds (ver las páginas 9-13)

● sehr grobe Körnung, very coarse grit, très gros grain, grano muy grueso
 ● grobe Körnung, coarse grit, gros grain, grano grueso
 ● mittlere Körnung, medium grit, grain moyen, grano mediano
 ● feine Körnung, fine grit, grain fin, grano fino
 ● extra feine Körnung, extra fine grit, grain extra fin, grano extra fino



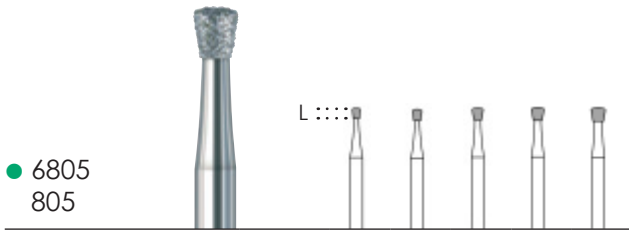

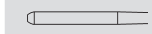
		6805/...	012	014	016	
● FG	ISO 806 314 010 534...					
FG	ISO 806 314 010 524...	805/...	010	012 ***	014 ***	016 ***
L mm			1,4	1,5	1,6	1,7

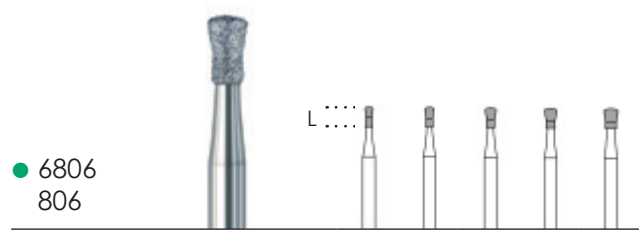

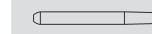
		6806/...	012	014	016	
● FG	ISO 806 314 019 534...					
FG	ISO 806 314 019 524...	806/...	010	012 ***	014 ***	016 ***
L mm			2,6	2,6	2,6	2,6



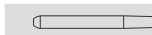

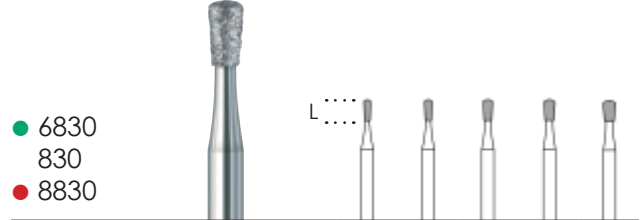
		807/...	012	016 ***
FG	ISO 806 314 225 524...			
L mm			3,5	4,0

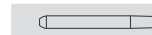

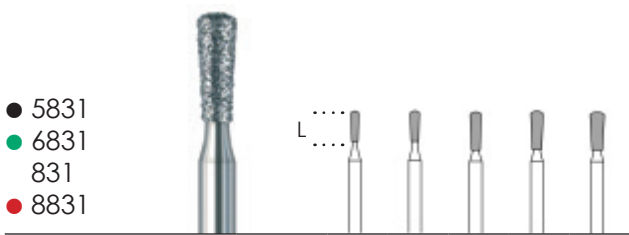

		6830/...	010	012 ***	014	016
● FG	ISO 806 314 233 534...					
FG	ISO 806 314 233 524...	830/...	009	010 ***	012 ***	014 ***
● FG	ISO 806 314 233 514...	8830/...		012 ***	014 ***	
L mm			2,7	2,7	2,7	2,7







		5831/...		014		
● FG	ISO 806 314 234 544...					
● FG	ISO 806 314 234 534...	6831/...	012	014 ***	016 ***	018
FG	ISO 806 314 234 524...	831/...	010	012 ***	014 ***	016 ***
● FG	ISO 806 314 234 514...	8831/...		012 ***	014 ***	
L mm			4,0	4,0	5,0	5,0



		6831R/...	012	014	016	018
● FG	ISO 806 314 238 534...					
FG	ISO 806 314 238 524...	831R/...	012	014	016	018
● FG	ISO 806 314 238 514...	8831R/...	012		016	
L mm			4,0	5,0	5,0	5,0

*** auch als COOL-Diamant-Schleifer lieferbar (siehe Seiten 9-13)
 also available as COOL-Diamond Instruments (see pages 9-13)
 Egalement disponible en instruments COOL Diamonds (voir pages 9-13)
 También disponible como instrumentos COOL Diamonds (ver las páginas 9-13)

● sehr grobe Körnung, very coarse grit, très gros grain, grano muy grueso } 
 ● grobe Körnung, coarse grit, gros grain, grano grueso } 
 ● mittlere Körnung, medium grit, grain moyen, grano mediano } 
 ● feine Körnung, fine grit, grain fin, grano fino } 
 ● extra feine Körnung, extra fine grit, grain extra fin, grano extra fino }

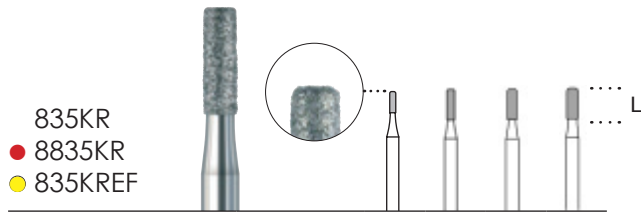

- 835KR
- 8835KR
- 835KREF



	FG	835KR/...	008	010	012	014
	ISO 806 314 156 524..			***	***	***
	● FG	8835KR/...		010	012	
	ISO 806 314 156 514...					
	● FG	835KREF/...			012	
	ISO 806 314 156 504...					
	L mm		3,0	4,0	4,0	4,0

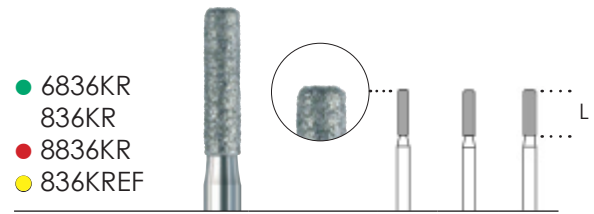

- 6836KR
- 836KR
- 8836KR
- 836KREF



	● FG	6836KR/...	012		
	ISO 806 314 157 534...		***		
	FG	836KR/...	012	014	016
	ISO 806 314 157 524...		***	***	***
	● FG	8836KR/...	012	014	016
	ISO 806 314 157 514...				
	● FG	836KREF/...	012		
	ISO 806 314 157 504...				
	L mm		6,0	6,0	6,0

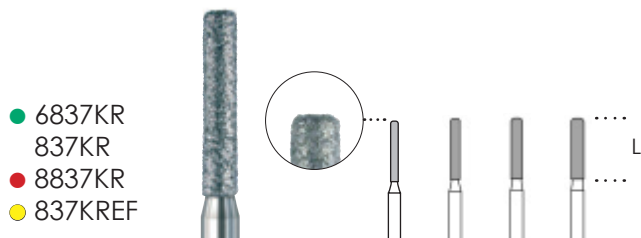

- 6837KR
- 837KR
- 8837KR
- 837KREF



	● FG	6837KR/...		012	014
	ISO 806 314 158 534...				***
	FG	837KR/...	010	012	014
	ISO 806 314 158 524...			***	***
	● FG	8837KR/...	010	012	014
	ISO 806 314 158 514...				016
	● FG	837KREF/...			014
	ISO 806 314 158 504...				
	L mm		8,0	8,0	8,0



- 837LKR
- 8837LKR



	FG	837LKR/...	012*	014
	ISO 806 314 586 524...			
	● FG	8837LKR/...	012*	014
	ISO 806 314 586 514...			
	L mm		10,0	10,0

*Drehzahlempfehlung/recommended speed/vitesse recommandée/velocidad recomendada 837LKR, 8837LKR 012 110.000-150.000 min⁻¹/r.p.m.



- 842KR



	FG	842KR/...	014*
	ISO 806 314 112 524...		
	L mm		12,0

*Drehzahlempfehlung/recommended speed/vitesse recommandée/velocidad recomendada 842KR 014 110.000-150.000 min⁻¹/r.p.m.

*** auch als COOL-Diamant-Schleifer lieferbar (siehe Seiten 9-13)
 also available as COOL-Diamond Instruments (see pages 9-13)
 Egalement disponible en instruments COOL Diamonds (voir pages 9-13)
 También disponible como instrumentos COOL Diamonds (ver las páginas 9-13)

- grobe Körnung, coarse grit, gros grain, grano grueso
- mittlere Körnung, medium grit, grain moyen, grano mediano
- feine Körnung, fine grit, grain fin, grano fino
- extra feine Körnung, extra fine grit, grain extra fin, grano extra fino



- 5836
- 6836
- 836
- 8836

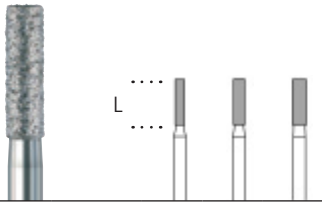

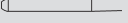
	● FG	5836/...	012			
		ISO 806 314 110 544...				
	● FG	6836/...	012	014	018	
		ISO 806 314 110 534...				
	FG	836/...	012	014	018	
		ISO 806 314 110 524...				
	● FG	8836/...	012			
		ISO 806 314 110 514...				
	L mm		6,0	6,0	6,0	

- 5837
- 6837
- 837
- 8837

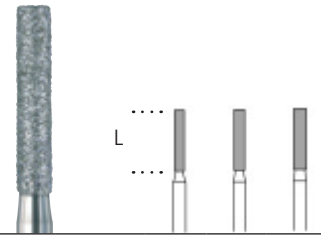

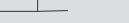
	● FG	5837/...		014		
		ISO 806 314 111 544...				
	● FG	6837/...	012	014	016	
		ISO 806 314 111 534...				
	FG	837/...	012	014	016	
		ISO 806 314 111 524...				
	● FG	8837/...		014		
		ISO 806 314 111 514...				
	L mm		8,0	8,0	8,0	

- 6835
- 835
- 8835

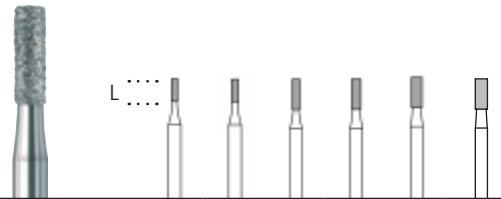

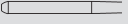
	● FG	6835/...		009	010	012	014	
		ISO 806 314 107 534...						
	FG	835/...	008	009	010	012	014	016
		ISO 806 314 107 524...						
	● FG	8835/...			010		014	
		ISO 806 314 107 514...						
	L mm		3,0	3,0	4,0	4,0	4,0	4,0

837L

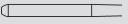

	FG	837L/...	014
		ISO 806 314 112 524...	
	L mm		10,0

842

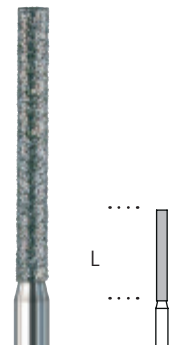

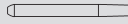
	FG	842/...	014*
		ISO 806 314 112 524...	
	L mm		12,0

*Drehzahlempfehlung/recommended speed/vitesse recommandée/velocidad recomendada 842 014 110.000-150.000 min⁻¹/r.p.m.

- sehr grobe Körnung, very coarse grit, très gros grain, grano muy grueso
- grobe Körnung, coarse grit, gros grain, grano grueso
- mittlere Körnung, medium grit, grain moyen, grano mediano
- feine Körnung, fine grit, grain fin, grano fino





FG	876/...	009	
ISO 806 314 287 524...			
● FG	8876/...	009	
ISO 806 314 287 514...			
L mm		5,0	



● FG	6877/...	010	012	
ISO 806 314 288 534...		***		
FG	877/...	010	012	014
ISO 806 314 288 524...		***	***	***
● FG	8877/...	010	012	014
ISO 806 314 288 514...		***		
L mm		6,0	6,0	6,0



● FG	5878/...			014	
ISO 806 314 289 544...					
● FG	6878/...	010*	012	014	016
ISO 806 314 289 534...			***	***	
FG	878/...	010*	012	014	016
ISO 806 314 289 524...			***	***	***
● FG	8878/...	010*	012	014	016
ISO 806 314 289 514...				***	
● FG	878EF/...		012	014	
ISO 806 314 289 504...					
L mm		8,0	8,0	8,0	8,0

*Drehzahlempfehlung/recommended speed/vitesse recommandée/velocidad recomendada 878 010 110.000-150.000 min⁻¹/r.p.m.
 6878 010 110.000-150.000 min⁻¹/r.p.m.

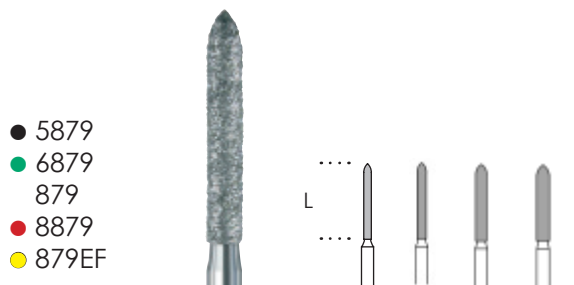

● FG	5879/...			014
ISO 806 314 290 544...				
● FG	6879/...		012*	014
ISO 806 314 290 534...			***	***
FG	879/...	010*	012*	014
ISO 806 314 290 524...			***	***
● FG	8879/...	010	012	014
ISO 806 314 290 514...			***	***
● FG	879EF/...		012	014
ISO 806 314 290 504...				
L mm		10,0	10,0	10,0

*Drehzahlempfehlung/recommended speed/vitesse recommandée/velocidad recomendada 879 010+012 110.000-150.000 min⁻¹/r.p.m.
 6879 012 110.000-150.000 min⁻¹/r.p.m.

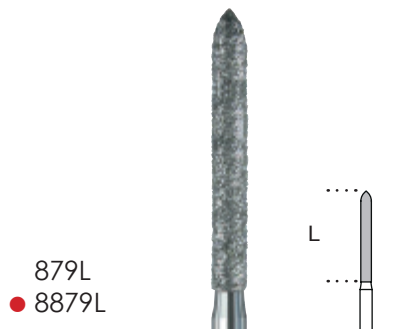

FG	879L/...	014*
ISO 806 314 291 524...		
● FG	8879L/...	014
ISO 806 314 291 514...		
L mm		12,0

*Drehzahlempfehlung/recommended speed/vitesse recommandée/velocidad recomendada 879L 014 110.000-150.000 min⁻¹/r.p.m.

*** auch als COOL-Diamant-Schleifer lieferbar (siehe Seiten 9-13)
 also available as COOL-Diamond Instruments (see pages 9-13)
 Egalement disponible en instruments COOL Diamonds (voir pages 9-13)
 También disponible como instrumentos COOL Diamonds (ver las páginas 9-13)

● sehr grobe Körnung, very coarse grit, très gros grain, grano muy grueso
 ● grobe Körnung, coarse grit, gros grain, grano grueso
 ● mittlere Körnung, medium grit, grain moyen, grano mediano
 ● feine Körnung, fine grit, grain fin, grano fino
 ● extra feine Körnung, extra fine grit, grain extra fin, grano extra fino





885

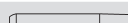

		
FG	885/...	012
ISO 806 314 130 524...		
L mm		8,0

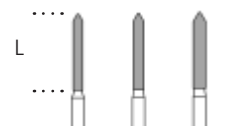

886

● 8886

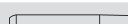

				
FG	886/...	012*	014	016
ISO 806 314 131 524...				***
● FG	8886/...		014	016
ISO 806 314 131 514...				
L mm		10,0	10,0	10,0

*Drehzahlempfehlung/recommended speed/vitesse recommandée/velocidad recomendada 886 012 110.000-150.000 min⁻¹/r.p.m.

*** auch als COOL-Diamant-Schleifer lieferbar (siehe Seiten 9-13)
 also available as COOL-Diamond Instruments (see pages 9-13)
 Egalement disponible en instruments COOL Diamonds (voir pages 9-13)
 También disponible como instrumentos COOL Diamonds (ver las páginas 9-13)

mittlere Körnung, medium grit, grain moyen, grano mediano

● feine Körnung, fine grit, grain fin, grano fino





● FG ISO 806 314 137 534...	6838/...			012
● FG ISO 806 314 137 524...	838/...	008	010 ***	012 ***
● FG ISO 806 314 137 514...	8838/...			012
L mm		3,0	4,0	4,0

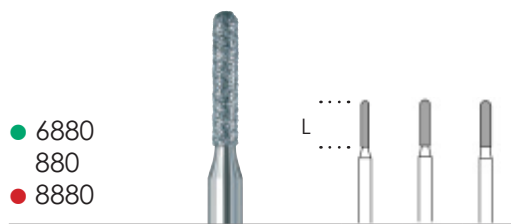

● FG ISO 806 314 140 534...	6880/...		012 ***	014 ***
● FG ISO 806 314 140 524...	880/...	010 ***	012 ***	014 ***
● FG ISO 806 314 140 514...	8880/...		012	014
L mm		6,0	6,0	6,0

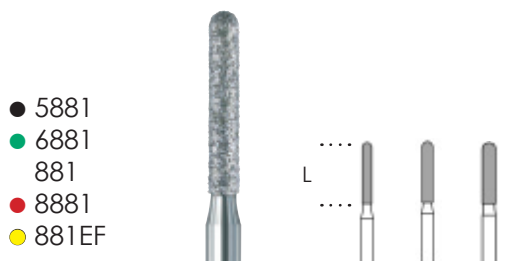

● FG ISO 806 314 141 544...	5881/...		014	
● FG ISO 806 314 141 534...	6881/...	012 ***	014 ***	016
● FG ISO 806 314 141 524...	881/...	012 ***	014 ***	016
● FG ISO 806 314 141 514...	8881/...	012 ***	014	016
● FG ISO 806 314 141 504...	881EF/...	012		
L mm		8,0	8,0	8,0



● FG ISO 806 314 142 534...	6882/...		014 ***	
● FG ISO 806 314 142 524...	882/...	012* ***	014 ***	
● FG ISO 806 314 142 514...	8882/...	012	014	016
L mm		10,0	10,0	10,0

*Drehzahlempfehlung/recommended speed/vitesse recommandée/
 velocidad recomendada 882 012 110.000-150.000 min⁻¹/r.p.m.

*** auch als COOL-Diamant-Schleifer lieferbar (siehe Seiten 9-13)
 also available as COOL-Diamond Instruments (see pages 9-13)
 Egalement disponible en instruments COOL Diamonds (voir pages 9-13)
 También disponible como instrumentos COOL Diamonds (ver las páginas 9-13)

● sehr grobe Körnung, very coarse grit, très gros grain, grano muy grueso
 ● grobe Körnung, coarse grit, gros grain, grano grueso
 ● mittlere Körnung, medium grit, grain moyen, grano mediano
 ● feine Körnung, fine grit, grain fin, grano fino
 ● extra feine Körnung, extra fine grit, grain extra fin, grano extra fino



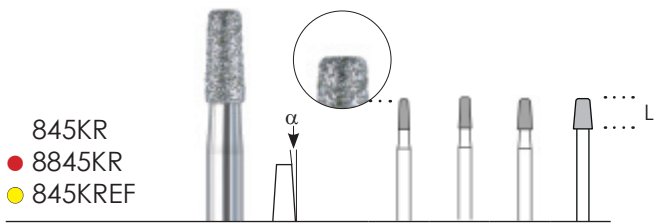

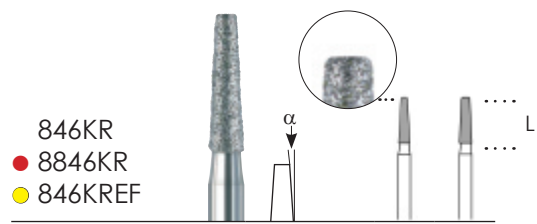

845KR					
● 8845KR					
● 845KREF					
					
FG	845KR/...		016	018	025
ISO 806 314 544 524...			***	***	
● FG	8845KR/...	014	016	018	025
ISO 806 314 544 514...					
● FG	845KREF/...		016		
ISO 806 314 544 504...					
L mm		4,0	4,0	4,0	4,0
α		3°	3°	3°	5°

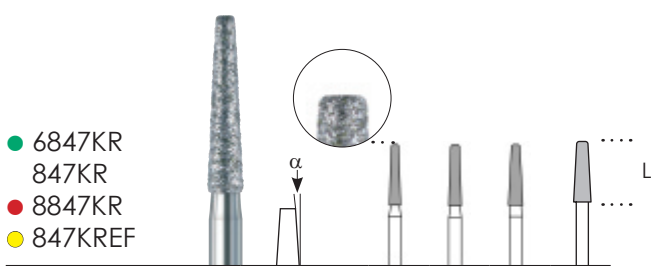

846KR				
● 8846KR				
● 846KREF				
				
FG	846KR/...		014	016
ISO 806 314 545 524...			***	***
● FG	8846KR/...	014	016	
ISO 806 314 545 514...				
● FG	846KREF/...			016
ISO 806 314 545 504...				
L mm			6,0	6,0
α			3°	3°



● 6847KR					
847KR					
● 8847KR					
● 847KREF					
					
● FG	6847KR/...			018	
ISO 806 314 546 534...					
FG	847KR/...	014	016	018	023
ISO 806 314 546 524...		***	***	***	
● FG	8847KR/...	014	016	018	023
ISO 806 314 546 514...					
● FG	847KREF/...		016		023
ISO 806 314 546 504...					
L mm		8,0	8,0	8,0	8,0
α		2°	2°	3°	3°

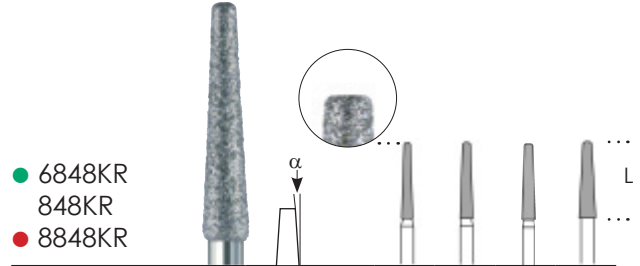

● 6848KR					
848KR					
● 8848KR					
					
● FG	6848KR/...		016	018	
ISO 806 314 553 534...					
FG	848KR/...	014	016	018	021
ISO 806 314 553 524...		***	***	***	
● FG	8848KR/...	014	016		021
ISO 806 314 553 514...					
L mm		10,0	10,0	10,0	10,0
α		2°	2°	2°	3°

*** auch als COOL-Diamant-Schleifer lieferbar (siehe Seiten 9-13)
 also available as COOL-Diamond Instruments (see pages 9-13)
 Egalement disponible en instruments COOL Diamonds (voir pages 9-13)
 También disponible como instrumentos COOL Diamonds (ver las páginas 9-13)

● grobe Körnung, coarse grit, gros grain, grano grueso
 ● mittlere Körnung, medium grit, grain moyen, grano mediano
 ● feine Körnung, fine grit, grain fin, grano fino
 ● extra feine Körnung, extra fine grit, grain extra fin, grano extra fino



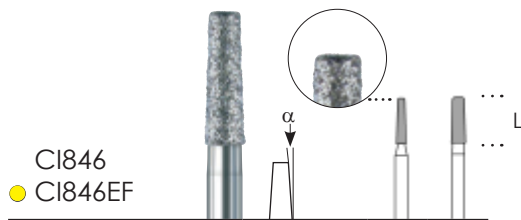

	CI846/...	012	018
FG ISO 806 314 545 524...			
	CI846EF/...	012	018
● FG ISO 806 314 545 504...			
L mm		6,0	6,0
α		1,5°	1,5°

- für Keramik Inlays
- ein Vollwinkel von 3° bietet beste Haftchancen für das Inlay
- for ceramic inlays
- a 3° round angle offers optimal bonding conditions for the inlay
- pour inlays en céramique
- le angle de 3° (angle de 360°) offre les meilleures chances d'adhérence aux inlays
- para ceramic inlays
- el ángulo de 3° (ángulo de 360°) ofrece la mejor adhesión para inlays



	CI847/...	018
FG ISO 806 314 546 524...		
	CI847EF/...	018
● FG ISO 806 314 546 504...		
L mm		8,0
α		1,5°

mittlere Körnung, medium grit, grain moyen, grano mediano



● extra feine Körnung, extra fine grit, grain extra fin, grano extra fino



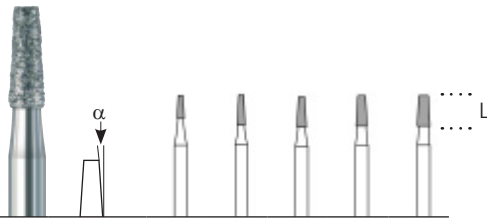

845

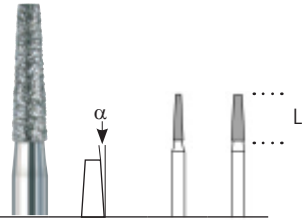

	845/...	009	010	012	014	016
FG ISO 806 314 168 524...						
L mm		3,0	4,0	4,0	4,0	4,0
α		3°	3°	3°	3°	3°

6846
846
8846



	6846/...		016
FG ISO 806 314 171 534...			
FG ISO 806 314 171 524...	846/...	012	016
FG ISO 806 314 171 514...	8846/...	012	
L mm		6,0	6,0
α		3°	3°

6847
847
8847

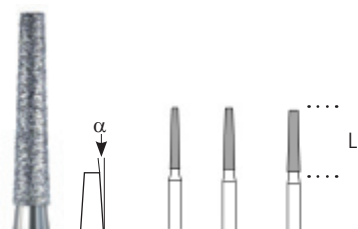

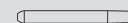

	6847/...	012		016
FG ISO 806 314 172 534...				
FG ISO 806 314 172 524...	847/...	012	014	016
FG ISO 806 314 172 514...	8847/...	012		
L mm		8,0	8,0	8,0
α		2°	2°	2°

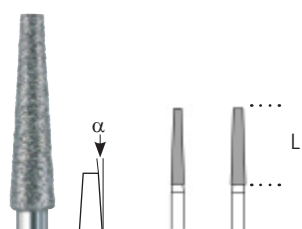
5848
6848
848
8848

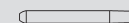

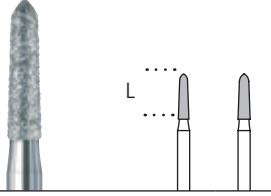

	5848/...	016	
FG ISO 806 314 173 544...			
FG ISO 806 314 173 534...	6848/...	016	018
FG ISO 806 314 173 524...	848/...	016	018
FG ISO 806 314 173 514...	8848/...	016	
L mm		10,0	10,0
α		2°	2°

● sehr grobe Körnung, very coarse grit, très gros grain, grano muy grueso } 
 ● grobe Körnung, coarse grit, gros grain, grano grueso }
 ● mittlere Körnung, medium grit, grain moyen, grano mediano }
 ● feine Körnung, fine grit, grain fin, grano fino } 



877K
 ● 8877K



	877K/...	014	016
FG ISO 806 314 297 524...			
● FG ISO 806 314 297 514...	8877K/...	014	016
L mm		6,0	6,0

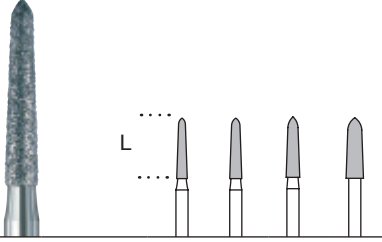

● 5878K
 ● 6878K
 878K
 ● 8878K

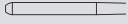

	5878K/...			018	
● FG ISO 806 314 298 544...					
● FG ISO 806 314 298 534...	6878K/...	014	016	018	023
FG ISO 806 314 298 524...	878K/...	014	016		
● FG ISO 806 314 298 514...	8878K/...	014	016		
L mm		8,0	8,0	8,0	8,0

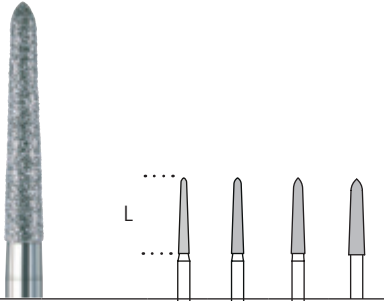



● 5879K
 ● 6879K
 879K
 ● 8879K

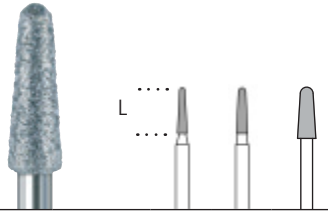

	5879K/...			018	
● FG ISO 806 314 299 544...					
● FG ISO 806 314 299 534...	6879K/...		016	018	021
FG ISO 806 314 299 524...	879K/...	014	016	018	
● FG ISO 806 314 299 514...	8879K/...	014	016	018	
L mm		10,0	10,0	10,0	10,0

- 6855
- 855
- 8855



	6855/...	012		025
● FG ISO 806 314 197 534...				
FG ISO 806 314 197 524...	855/...	012	014 ***	025
● FG ISO 806 314 197 514...	8855/...	012		
L mm		6,0	6,0	7,0

- 5850
- 6850
- 850
- 8850

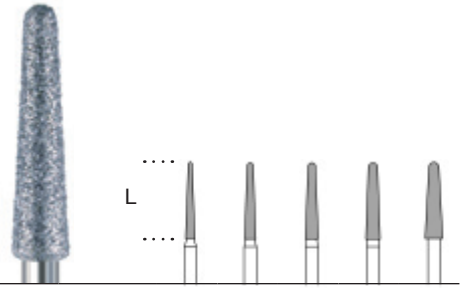

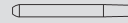

	5850/...			016		
● FG ISO 806 314 199 544...						
● FG ISO 806 314 199 534...	6850/...	012	014	016 ***	018 ***	023
FG ISO 806 314 199 524...	850/...	012	014	016 ***	018 ***	023
● FG ISO 806 314 199 514...	8850/...	012	014	016		
L mm		10,0	10,0	10,0	10,0	10,0

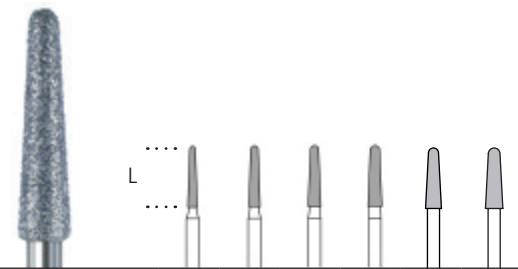
- 5856
- 6856
- 856
- 8856
- 856EF

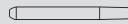

	5856/...		014	016	018		
● FG ISO 806 314 198 544...							
● FG ISO 806 314 198 534...	6856/...	012	014	016 ***		021	023
FG ISO 806 314 198 524...	856/...	012	014	016 ***	018		
● FG ISO 806 314 198 514...	8856/...	012	014	016	018	021	
● FG ISO 806 314 198 504...	856EF/...	012		016			
L mm		8,0	8,0	8,0	8,0	8,0	8,0

*** auch als COOL-Diamant-Schleifer lieferbar (siehe Seiten 9-13)
 also available as COOL-Diamond Instruments (see pages 9-13)
 Egalement disponible en instruments COOL Diamonds (voir pages 9-13)
 También disponible como instrumentos COOL Diamonds (ver las páginas 9-13)

● sehr grobe Körnung, very coarse grit, très gros grain, grano muy grueso }
 ● grobe Körnung, coarse grit, gros grain, grano grueso }
 ● mittlere Körnung, medium grit, grain moyen, grano mediano }
 ● feine Körnung, fine grit, grain fin, grano fino }
 ● extra feine Körnung, extra fine grit, grain extra fin, grano extra fino }

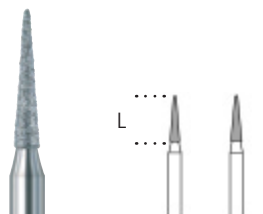

- 6852
852
- 8852
- 852EF

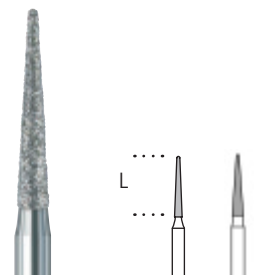

● FG ISO 806 314 164 534...	6852/...	012	
FG ISO 806 314 164 524...	852/...	012	
● FG ISO 806 314 164 514...	8852/...	012	
● FG ISO 806 314 164 504...	852EF/...		014
L mm		6,0	6,0

- 6858
858
- 8858
- 858EF



● FG ISO 806 314 165 534...	6858/...		014 ***
FG ISO 806 314 165 524...	858/...	010	014 ***
● FG ISO 806 314 165 514...	8858/...		014
● FG ISO 806 314 165 504...	858EF/...		014
L mm		8,0	8,0

- 6859
859
- 8859
- 859EF

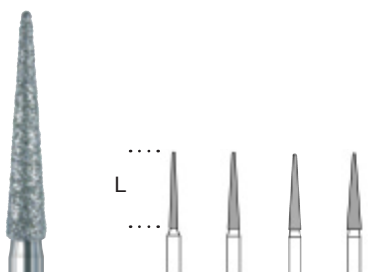

● FG ISO 806 314 166 534...	6859/...		014 ***	018 ***
FG ISO 806 314 166 524...	859/...	010	014 ***	016 ***
● FG ISO 806 314 166 514...	8859/...	010	014 ***	018
● FG ISO 806 314 166 504...	859EF/...	010	014	018
L mm		10,0	10,0	10,0

*** auch als COOL-Diamant-Schleifer lieferbar (siehe Seiten 9-13)
 also available as COOL-Diamond Instruments (see pages 9-13)
 Egalement disponible en instruments COOL Diamonds (voir pages 9-13)
 También disponible como instrumentos COOL Diamonds (ver las páginas 9-13)

● grobe Körnung, coarse grit, gros grain, grano grueso
 mittlere Körnung, medium grit, grain moyen, grano mediano
 ● feine Körnung, fine grit, grain fin, grano fino
 ● extra feine Körnung, extra fine grit, grain extra fin, grano extra fino





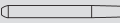

			
FG	860/...	010	012
ISO 806 314 245 524...			***
● FG	8860/...		012
ISO 806 314 245 514...			
● FG	860EF/...		012
ISO 806 314 245 504...			
L mm		4,0	5,0

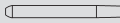

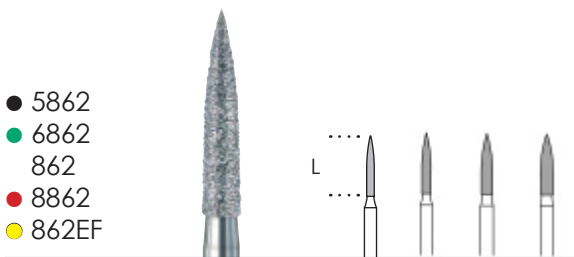
			
FG	861/...		012
ISO 806 314 248 524...			
● FG	8861/...		012
ISO 806 314 248 514...			
L mm			6,0



					
● FG	5862/...		012		
ISO 806 314 249 544...					
● FG	6862/...		012	014	016
ISO 806 314 249 534...				***	***
FG	862/...		012	014	016
ISO 806 314 249 524...			***	***	***
● FG	8862/...		012		016
ISO 806 314 249 514...			***		***
● FG	862EF/...	010	012		016
ISO 806 314 249 504...					
L mm		8,0	8,0	8,0	8,0

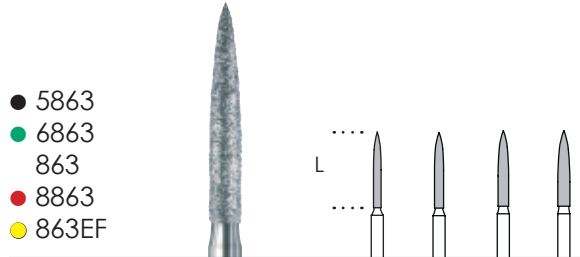

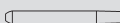
					
● FG	5863/...				016
ISO 806 314 250 544...					
● FG	6863/...		012	014	016
ISO 806 314 250 534...			***	***	***
FG	863/...		012	014	016
ISO 806 314 250 524...			***	***	***
● FG	8863/...	010*	012		016
ISO 806 314 250 514...			***		***
● FG	863EF/...		012		016
ISO 806 314 250 504...					
L mm		10,0	10,0	10,0	10,0



*Drehzahlmpfehlung/recommended speed/vitesse recommandée/velocidad recomendada 8863 010 110.000-150.000 min⁻¹/r.p.m.

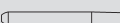

		
FG	864/...	014*
ISO 806 314 251 524...		
● FG	8864/...	014
ISO 806 314 251 514...		
L mm		12,0

*Drehzahlmpfehlung/recommended speed/vitesse recommandée/velocidad recomendada 864 014 110.000-150.000 min⁻¹/r.p.m.

*** auch als COOL-Diamant-Schleifer lieferbar (siehe Seiten 9-13)
 also available as COOL-Diamond Instruments (see pages 9-13)
 Egalement disponible en instruments COOL Diamonds (voir pages 9-13)
 También disponible como instrumentos COOL Diamonds (ver las páginas 9-13)

● sehr grobe Körnung, very coarse grit, très gros grain, grano muy grueso } 
 ● grobe Körnung, coarse grit, gros grain, grano grueso }
 ● mittlere Körnung, medium grit, grain moyen, grano mediano }
 ● feine Körnung, fine grit, grain fin, grano fino }
 ● extra feine Körnung, extra fine grit, grain extra fin, grano extra fino } 



- 6889
- 889
- 8889



● FG	6889/...	009	010
ISO 806 314 540 534...			
FG	889/...	009	
ISO 806 314 540 524...			
● FG	8889/...	009	010
ISO 806 314 540 514...			
L mm		4,0	4,0

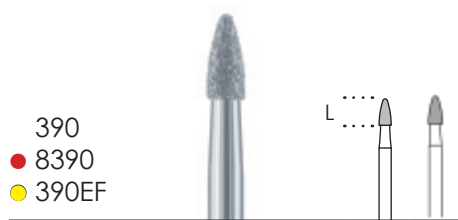

- 390
- 8390
- 390EF



FG	390/...	016	018
ISO 806 314 274 524...			
● FG	8390/...	016	018
ISO 806 314 274 514...			
● FG	390EF/...	016	018
ISO 806 314 274 504...			
L mm		3,5	3,7

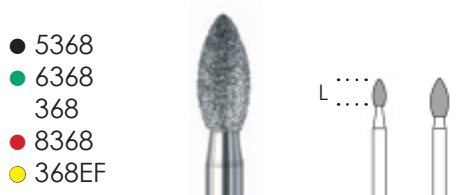

- 5368
- 6368
- 368
- 8368
- 368EF



● FG	5368/...		023
ISO 806 314 277 544...			
● FG	6368/...	016	023
ISO 806 314 277 534...			***
FG	368/...	016	023
ISO 806 314 277 524...		***	***
● FG	8368/...	016	023
ISO 806 314 277 514...			***
● FG	368EF/...	016	023
ISO 806 314 277 504...			
L mm		3,5	5,0

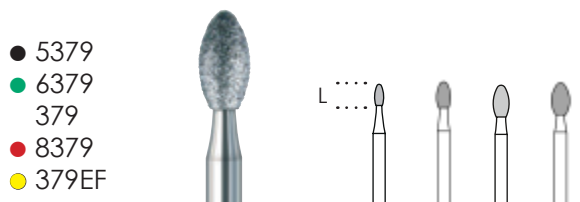

- 5379
- 6379
- 379
- 8379
- 379EF



● FG	5379/...				023
ISO 806 314 277 544...					
● FG	6379/...				023
ISO 806 314 277 534...					
FG	379/...		018		023
ISO 806 314 277 524...					
● FG	8379/...	012	018	021	023
ISO 806 314 277 514...					
● FG	379EF/...		018		023
ISO 806 314 277 504...					
L mm		2,8	3,4	4,2	4,2



- 5811
- 811



● FG	5811/...	033	037
ISO 806 314 277 544...			
FG	811/...	033	
ISO 806 314 038 524...			
FG	811/...		037
ISO 806 314 039 524...			
L mm		4,2	7,0



- 899
- 8899



FG	899/...	021	027	031
ISO 806 314 033 524...				
● FG	8899/...	021	027	031
ISO 806 314 033 514...				
L mm		6,5	7,0	7,0

*** auch als COOL-Diamant-Schleifer lieferbar (siehe Seiten 9-13)
 also available as COOL-Diamond Instruments (see pages 9-13)
 Egalement disponible en instruments COOL Diamonds (voir pages 9-13)
 También disponible como instrumentos COOL Diamonds (ver las páginas 9-13)

● sehr grobe Körnung, very coarse grit, très gros grain, grano muy grueso }
 ● grobe Körnung, coarse grit, gros grain, grano grueso }
 ● mittlere Körnung, medium grit, grain moyen, grano mediano }
 ● feine Körnung, fine grit, grain fin, grano fino }
 ● extra feine Körnung, extra fine grit, grain extra fin, grano extra fino }



Interdentale Ausarbeitung
 Interproximal trimming
 Elaboration interdentaire
 Elaboración interdental



● 8392

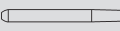

			
● FG	8392/...	016	
ISO 806 314 465 514...			
L mm		5,0	



● 957EF

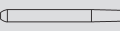

			
● FG	957EF/...	009	
ISO 806 314 195 504...			
L mm		3,0	



851

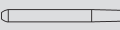

			
FG	851/...	012	016
ISO 806 314 219 524...			
L mm		8,0	8,0



● 8863GK
 ● 863GKEF



			
● FG	8863GK/...	012	
ISO 806 314 256 514...			
● FG	863GKEF/...	012	
ISO 806 314 256 504...			
L mm		10,0	



857

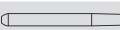

			
FG	857/...	014	
ISO 806 314 220 524...			
L mm		10,5	



839

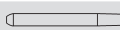

			
FG	839/...	012	
ISO 806 314 150 524...			

- grobe Körnung, coarse grit, gros grain, grano grueso
 mittlere Körnung, medium grit, grain moyen, grano mediano
- feine Körnung, fine grit, grain fin, grano fino
- extra feine Körnung, extra fine grit, grain extra fin, grano extra fino





		818/...	050
FG	ISO 806 314 041 524...		
L mm			0,7



● 5909	● 6909	● 909	
		5909/...	040
● FG	ISO 806 314 068 534...		
● FG	ISO 806 314 068 534...	6909/...	040
FG	ISO 806 314 068 524...	909/...	040 055
L mm			1,0 2,0

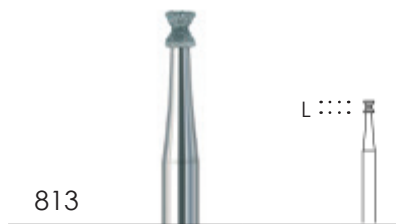

		813/...	014
FG	ISO 806 314 032 524...		
L mm			1,5



			833A/...	025
FG	ISO 806 314 219 524...			
L mm				1,5

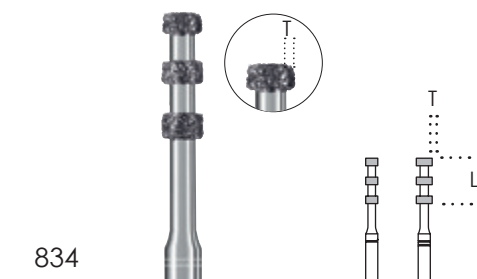

		834/...	016	021
FG	ISO 806 314 219 524...			
L mm			6,0	6,0
T mm			0,3	0,5

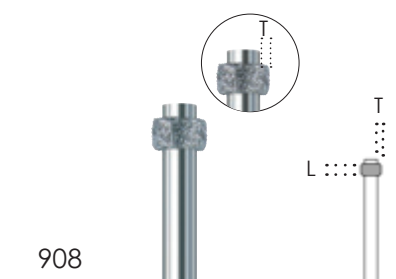

		908/...	026
FG x-lg	ISO 806 316 073 524...		
L mm			1,5
T mm			0,5

818/5909/6909/909 =

● sehr grobe Körnung, very coarse grit, très gros grain, grano muy grueso }
 ● grobe Körnung, coarse grit, gros grain, grano grueso
 mittlere Körnung, medium grit, grain moyen, grano mediano

Micro Prep

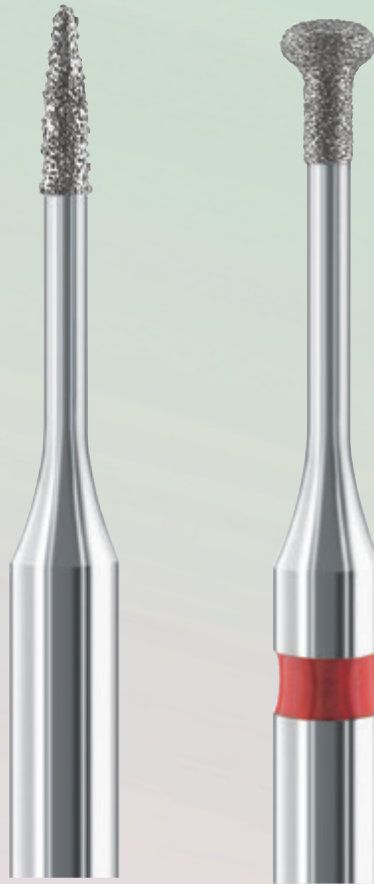

Minimalinvasive Präparationstechnik

Für das selektive, minimalinvasive Präparieren benötigt man speziell konzipierte Instrumente. Kleinste Arbeitsteildurchmesser, anwendungsorientierte Formen, verschiedene Diamantkorngrößen, lange, schlanke Hälse und ein perfekter Rundlauf sind die wesentlichen Merkmale dieser Instrumente. Die lange, schlanke Halskonstruktion ermöglicht eine perfekte, optische Kontrolle über die Präparation in der Tiefe des Dentins. Selbst an schwer zugänglichen Stellen kann gezielt gearbeitet werden, ohne den Schmelz weit zu öffnen wie das bei gleichen Arbeitsteildurchmessern mit üblicher Halskonstruktion der Fall ist.

Preparation technique based on minimum contact

For a selective, minimal invasive preparation, you need specially designed instruments. The smallest working part diameter, application-oriented shapes, various diamond grit sizes, long, thin necks and a perfect concentric running are the essential characteristics of such instruments. The long thin neck construction allows a perfect optimal control during preparation in the depth of the dentine. Even in hard-to-reach places targeted work can be done without opening the enamel too much, which could be in the case when using the same working part diameters with a normal neck construction.

Préparation invasive minimale

Pour le traitement sélectif, minimalinvasif il faut des instruments spécialement conçus. Les plus petits diamètres des parties travaillantes, les formes adaptées, les différentes tailles de grains, les cols longs et minces et une parfaite concentricité sont les caractéristiques importantes de ces instruments. La construction longue et mince du col permet un parfait contrôle visuel durant le traitement dans la profondeur de la dentine. Ceci permet le traitement précis même aux endroits d'accès difficile sans ouvrir trop l'émail comme c'est le cas avec un instrument d'un diamètre égal avec un col conventionnel.

Técnica de preparación invasiva minimal

Para la preparación selectiva e invasiva mínima, se necesita instrumentos especialmente concebidos. Pequeños diámetros de las partes activas, formas orientadas a la aplicación, diferentes tamaños de grano diamantado, cuellos largos y delgados y una estabilidad concéntrica perfecta son las principales características de estos instrumentos. La fabricación larga y delgada de los cuellos, permite un control óptico perfecto del trabajo sobre la dentina. Aún así las partes con difícil acceso puedan ser tratadas directamente sin necesidad de abrir el esmalte como es el caso, aplicando instrumentos con los mismos diámetros de las partes de fresado y con los cuellos de tamaño convencional.

MI801





	MI801	010
FG		
ISO 806 314 004 524...		

MI802
● MI8802



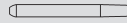

	MI802	014
FG		
ISO 806 314 104 524...		
● FG	MI8802	014
ISO 806 314 104 514...		
L mm		2,6

MI806
● MI8806



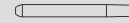

	MI806	014
FG		
ISO 806 314 293 524...		
● FG	MI8806	014
ISO 806 314 293 514...		
L mm		2,6

MI830
● MI8830



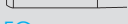

	MI830	009
FG		
ISO 806 314 231 524...		
● FG	MI8830	009
ISO 806 314 231 514...		
L mm		2,6

MI830
● MI8830



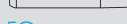

	MI830	012
FG		
ISO 806 314 293 524...		
● FG	MI8830	012
ISO 806 314 293 514...		
L mm		2,6

MI838
● MI8838



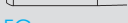

	MI838	007
FG		
ISO 806 314 125 524...		
● FG	MI8838	007
ISO 806 314 125 514...		
L mm		2,6

MI889
● MI8889



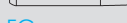

	MI889	007
FG		
ISO 806 314 262 524...		
● FG	MI8889	007
ISO 806 314 262 514...		
L mm		2,6

Drehzahlempfehlung/recommended speed/vitesse recommandée/velocidad recomendada

mittlere Körnung/medium grit/grain moyen/grano medio

MI 801 010	140.000 min ⁻¹	MI 830 012	130.000 min ⁻¹
MI 802 014	120.000 min ⁻¹	MI 838 007	150.000 min ⁻¹
MI 806 014	120.000 min ⁻¹	MI 889 007	150.000 min ⁻¹
MI 830 009	140.000 min ⁻¹		

feine Körnung/fine grit/grain fin/grano fino

MI 8802 014	100.000 min ⁻¹	MI 8830 012	100.000 min ⁻¹
MI 8806 014	100.000 min ⁻¹	MI 8838 007	120.000 min ⁻¹
MI 8830 009	110.000 min ⁻¹	MI 8889 007	120.000 min ⁻¹

ZIRAMANT



Spezialdiamantierung für Zirkonoxid/special diamond coating for zirconia

diamantée spéciale pour oxyde de zirconium/recubrimiento diamantado especial para óxido de circonio

Korrektur von Zirkon Abutments
correction of zirconia abutments
correction de piliers de zirconium
retoque de pilares de circonio

Feinkorrektur bei der Zirkon-Inkorporation
fine correction during incorporation of zirconia
correction de précision lors de l'incorporation
de zirconium
retoques precisos durante la incorporación de
circonio

- 855Z
- 862Z
- 379Z

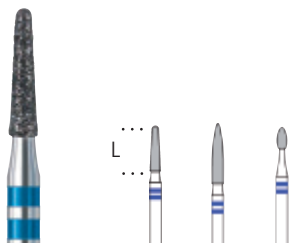

- 8801LZ
- 8838LZ

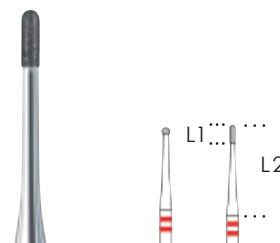

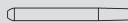
	855Z/...	014		
●● FG ISO 806 314 197 525...				
●● FG ISO 806 314 249 525...	862Z/...		016	
●● FG ISO 806 314 277 525...	379Z/...			014
L mm		6,0	8,0	2,8





	8801LZ/...	011		
●● FG x-lg ISO 806 316 001 515...				
●● FG x-lg ISO 806 316 137 515...	8838LZ/...			009
L1 mm				2,3
L2 mm			10,8	11,8

Trepanieren von Zirkonoxid-Restaurationen
trepanation of zirconia restorations
trépanation des restaurations d'oxyde de zirconium
trepanación de óxido de circonio de restauraciones

Entfernen von Zirkonoxid-Restaurationen
removal of zirconia restorations
retrait des restaurations de l'oxyde de zirconium
retracción de óxido de circonio de restauraciones

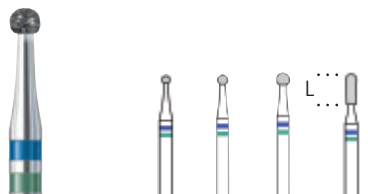
- 6801Z
- 6831RZ



	6801Z/...	010	014	018	-
●● FG ISO 806 314 001 535...					
●● FG ISO 806 314 238 535...	6831RZ/...				014
L mm					4,0

- 6880Z
- 6855Z

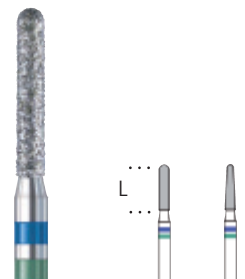

	6880Z/...	014		
●● FG ISO 806 314 140 535...				
●● FG ISO 806 314 197 535...	6855Z/...			014
L mm			6,0	6,0

●● grobe Körnung, coarse grit, gros grain, grano grueso
●● mittlere Körnung, medium grit, grain moyen, grano mediano
●● feine Körnung, fine grit, grain fin, grano fino

Diä PERIO-PRO

Zahnmedizin
Dentistry
Odontologie
Odontologia

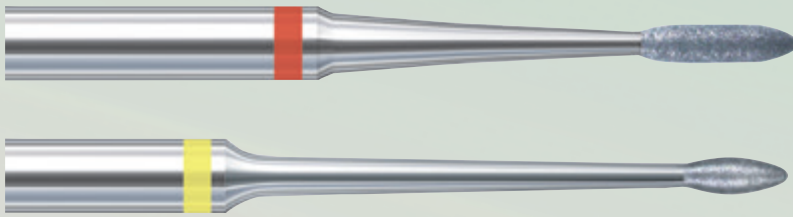

Feine Körnung

- Schonende Beseitigung von supra- und subgingivalem Zahnstein bzw. Konkrementen.
- Odontoplastik (Beseitigung natürlicher Plaqueretentionsstellen).
- Vorreinigen der intraalveolären Knochen tasche und Wurzelreinigung.
- Drehzahlempfehlung: 8.000 - 12.000 min⁻¹

fine grit

- gentle removal of supra- and subgingival calculus or rather concretions.
- removal of natural plaque retention points.
- pre-cleaning of intraalveolar intrabony pocket and root cleaning.
- recommended speed: 8.000 - 12.000 r.p.m.

grain fin

- élimination, en toute sécurité, du tartre sus-gingival et sousgingival et d'autres dépôts.
- odontoplastie (Élimination des zones de rétention de plaque dentaire naturelles).
- pre-nettoyage d'une poche intra-osseuse intra-alvéolaire et nettoyage des racines.
- vitesse recommandée: 8.000 - 12.000 min⁻¹

grano fino

- eliminación, de manera cuidadosa, del cálculo subgingival y supragingival, y de otras concreciones.
- eliminación de placas de retención naturales, es decir de grietas, fisuras y bifurcaciones mediante operaciones odontoplásticas.
- limpieza previa de la bolsa infraósea y limp. de los raices.
- velocidad recomendada: 8.000 - 12.000 min⁻¹

Extra feine Körnung

- Abschließende Wurzelglättung, auch bei beginnender Furkationsbeteiligung.
- Glättung des Wurzelzementes bei parodontal geschädigten Zähnen.
- Entfernung von Zementüberschüssen nach dem Einsetzen von festsitzendem Zahnersatz.

extra fine grit

- final root and smoothing, also at early infestation of furcation.
- smoothing of the root cementum of parodontal damaged teeth.
- removal of cementum surplus after fitting of crowns and bridges.

grain extra fin

- lissage final des racines, même en cas de bifurcation initiale.
- lissage du ciment des racines de dents cariées dans la zone parodontale.
- élimination des excédents de ciment après la mise en place des couronnes et bridges.

grano extra fino

- limpieza final y alisado de las raices, incluso en caso de bifurcación inicial.
- alisado del cemento de las raices de dientes deterioradas en el ámbito parodontal.
- eliminación del cemento excesivo después de colocar coronas y puentes.



- 8406LF
- 8406LEF



● W/RA/CA ISO 806 204 261 514...	8406LF/...	012
● W/RA/CA ISO 806 204 261 504...	8406LEF/...	012
L mm		5,0



- 8407LF
- 8407LEF



● W/RA/CA ISO 806 204 259 514...	8407LF/...	012
● W/RA/CA ISO 806 204 259 504...	8407LEF/...	012
L mm		2,9

* Auch als Hartmetall-Instrumente Longlife Perio-Pro erhältlich.
* Also available as carbide instruments Longlife Perio-Pro.
* Egalement disponible en instruments carbure Longlife Perio-Pro.
* También disponible como instrumentos de carburo Longlife Perio-Pro.

Zahnmedizin



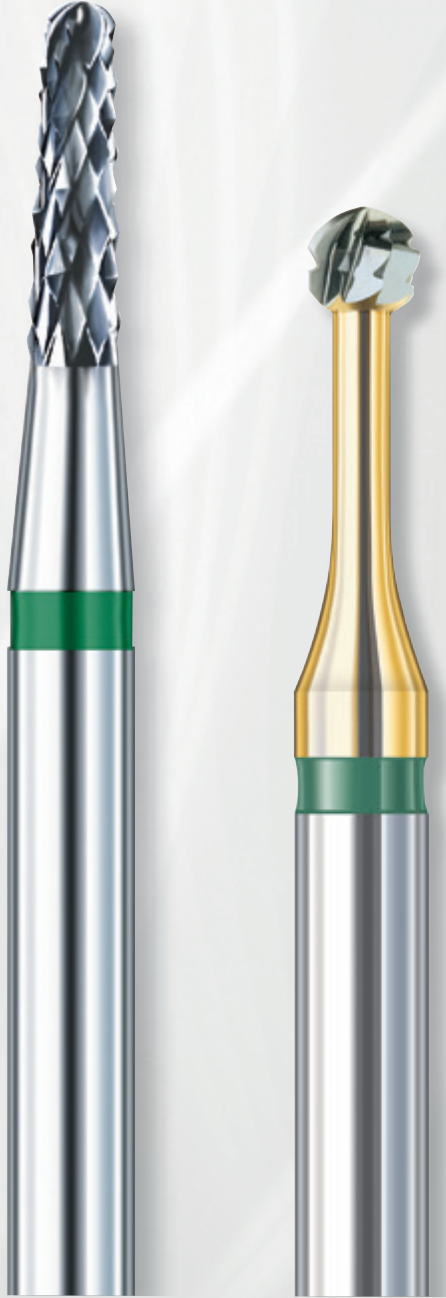













Dentistry • Odontologie • Odontologia



Hartmetall

Carbide • Carbure • Carbuero

Anwendungsbeispiele Examples of application Exemples d'application Ejemplos de aplicaciones	38
Kavitäten- und Fissurenbohrer Excavating and fissure burs Fraises carbure pour cavités et fraises à fissures Fresas de carburo para excavaciones y fisuras	39-43
Kronentrenner Crown cutters Fraises coupes-couronnes Fresas corta-coronas	44-46
Finierer Finishing burs Fraises à finir Fresas para acabar	47-51
LongLife PERIO-PRO	52
Chirurgie-Instrumente, Knochenfräser, Endo Erweiterer Surgical instruments, bone cutters, endo reamer Surgical instruments, bone cutters, endo reamer Surgical instruments, bone cutters, endo reamer	53-55

Einsatzgebiet working on domaine d'applic. uso en sector	Arbeitsgang working process phase de travail fase de trabajo	Verzahnungsart type of cuts type de denture tipos de dentado	Instrumentenbeispiel examples of instr. exempl. d'instruments ej. de los instrumentos	ISO-Ø	empf. Drehzahl min ⁻¹ recom. speed r.p.m. vit. de rotation rec. veloc. recomendada
Schmelz, Dentin enamel, dentine email, Dentine esmalte, Dentina	Exkavieren excavating excavation excavación	Schnittfreundige Verzahnung mit/ohne Spezial-Querhieb; mit/ohne schlankem Hals power cut with/without special cross-cut, with/without slender neck denture particulièrement sécante avec/sans taille spéciale, avec/sans col mince dentado de alto rendimiento, con/sin talla special, con/sin cuello delgado	1SXM W/RA/CA  1SX W/RA/CA  1S W/RA/CA 	008-012 014-016 018-027	3.000 - 2.500 2.000 - 1.500 1.000 - 500
Schmelz, Dentin enamel, Dentine email, Dentine esmalte, Dentina	Präparieren preparation préparation preparación	Mittlere Verzahnung medium cut denture moyenne dentado medio Mittlere Verzahnung mit Standard-Querhieb medium cut with standard cross-cut denture moyenne avec taille transversale standard dentado medio con corte transversal	21R FG  31R FG 	005-009 010-018 008-012 014-016	225.000 - 165.000 215.000 - 62.000 225.000 - 120.000 180.000 - 80.000
Amalgam amalgam amalgame amalgama	Amalgam-Entfernung amalgam removal elimination d'amalgame eliminación de amalgama	Mittlere Spezial-Kreuzverzahnung mit Überlaufender Schneide medium special double-cut with overflow cut denture spéciale croisée moyenne avec une lame frontale dentado medio especial cruzado que continua en la cabeza	32HG FG 	012	200.000 - 180.000
Metalllegierungen metal alloys alliages métalliques aleaciones metalicas	Auftrennen von Kronen/Brücken cutting of crowns and bridges séparation des couronnes et bridges separación de coronas y puentes	Mittlere Verzahnung mit feinem Querhieb/Mittlere Kreuzverzahnung/Diamantverzahnung medium cut with fine cross-cut/medium double cut/diamond cut denture moyenne avec taille transversale fine/Denture croisée moyenne/ denture diamant dentado media con talla transversal fina/dentado medio cruzado/dentado „Diamante“	36R FG  21RX FG  36RD FG 	010-012	200.000 - 180.000
Wurzeloberflächen root surfaces surface des racines superficie de las raices	Säubern/Glätten scaling/root-planing nettoyage/lissage limpieza/alizado	Polygonales Arbeitsteil (ohne scharfe Schneiden) polygonal working part (without sharp edges) partie trav. polygonale (sans tranchants) parte de trabajo provista polygonal (sin cortantes vivos)	407/407L W/RA/CA  406/406L W/RA/CA 	012 010+012	12.000 - 8.000 12.000 - 8.000
Schmelz, Dentin, Komposit, Metall, Keramik enamel, dentine composite, metal ceramic email, dentine, composite, céramique, métal esmalte, dentina composite, cerámica, metal	Finieren finishing finissage acabado	Finierer-Verzahnung mittel, fein, ultra-fein finishing cut medium, fine, super-fine denture de fraise à finir moyenne, fine, ultra-fine dentado de fresas para acabar medio, fino, superfino	44E FG  44 E-F FG  44E-UF FG 	008-010 012-016 018-027	70.000 - 10.000 60.000 - 10.000 35.000 - 10.000
Knochen bones os huesos	Chirurgische Eingriffe surgery interventions chirurgic intervenciones quirúr	chirurgie-Spezialverzahnungen surgery special cuts dentures spéciales pour chirurgie dentado especial para la cirugía	141 HST/HP/PM  FGx-lg 	010-050 010-023	5.300 - 800 65.000 - 15.000

Hartmetall • Kavitäten- und Fissurenbohrer
 Carbide • Excavating and fissure burs
 Carbure • Fraises carbure pour cavités et fraises à fissures
 Carbuo • Fresas de carburo para excavaciones y fisuras

Zahnmedizin
 Dentistry
 Odontologie
 Odontologia

Freie Sicht auf das Exkavationsgebiet

Die extrem schlanke Halskonstruktion der neuen Hartmetall-Rundbohrer 1SXM sorgt selbst bei minimalen Zugängen für mehr Übersicht. Neben dem Plus an Übersicht gewährleistet die bewährte SX-Verzahnung einen ruhigen Rundlauf bei der Kavitätenpräparation und Exkavation.

Clear view on the excavation area

The extremely slender neck of the new carbide round bur 1SXM permits a better overview even by minimal access. Besides the advantage of a better overview the reliable SX-cut ensures a smooth runout during cavity preparation and excavation.

Bonne visibilité sur la zone d'excavation

Le col extrêmement mince de la nouvelle fraise en carbure 1SXM permet une meilleure visibilité même aux accès restreints. Complémentairement à cette bonne visibilité, la denture SX éprouvée garanti une rotation calme lors des traitements de cavités et d'excavations.

Vista libre sobre la zona de excavaciones

La construcción de las fresas de carburo redondas más modernas con el cuello muy delgado permite buena visibilidad durante un acceso de excavación mínimo. Aparte de la buena visibilidad, esta fresa con el corte cruzado SX ofrece poca vibración durante la preparación de cavidad y la excavación.

zügiges, vibrationsarmes Exkavieren bei freier Sicht trotz minimalen Exkavationszugang
 fast, low vibration excavating with a clear view even by minimum excavating space
 excavation rapide avec peu de vibration et une bonne visibilité même lors d'un accès minimal pour l'excavation
 excavaciones rápidas con poca vibración, con buena visibilidad a pesar de un acceso de excavación mínimo

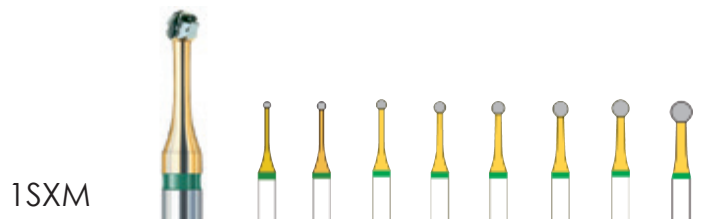

mit schlanker Halskonstruktion
 with slender neck construction
 avec la construction du col mince
 con una construcción delgada del cuello

US-No	2SXM	3SXM	4SXM	5SXM	6SXM	7SXM	8SXM	10SXM
W/RA/CA ISO 500 204 004 019...	010	012	014	016	018	021	023	027
W-Ig/RA-Ig/CA-Ig ISO 500 205 004 019...	•	•	•	•	•	•	•	•

Vibrationsarmes Präparieren mit SX-Verzahnung

Low-vibration preparation with SX cut

Préparation à faible vibration avec coupe SX

Preparación de baja vibración con corte SX



zügiges, vibrationsarmes Exkavieren
 fast, low vibration excavating
 excavation rapide avec peu de vibration
 excavaciones rápidas con poca vibración

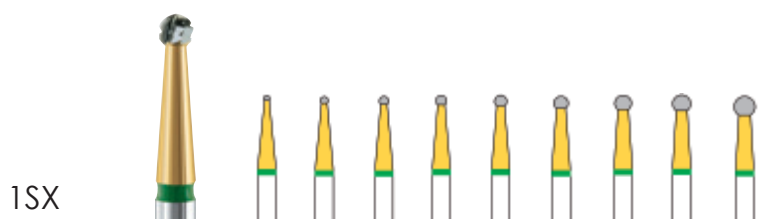

Präparieren mit Standard-Verzahnung

Preparation with standard cut

Préparation avec coupe standard

Preparación con corte estándar



US-No	1SX	2SX	3SX	4SX	5SX	6SX	7SX	8SX	10SX
W/RA/CA ISO 500 204 001 019...	008	010	012	014	016	018	021	023	027
W-Ig/RA-Ig/CA-Ig ISO 500 205 001 019...		•		•		•		•	•



Hartmetall • Kavitäten- und Fissurenbohrer

Carbide • Excavating and fissure burs

Carbure • Fraises carbure pour cavités et fraises à fissures

Carbuo • Fresas de carburo para excavaciones y fisuras

zügiges Exkavieren
fast excavating
excavation rapide
excavaciones rápidas

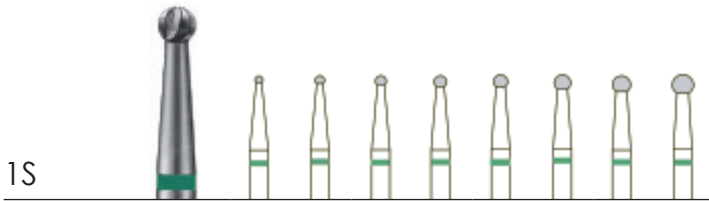

1S

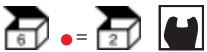

schnitffreudige Verzahnung, grüner Ring
power cut, green ring
denture particulièrement sécante, bague verte
dentado de alto rendimiento, anillo verde

US-No	2S	3S	4S	5S	6S	7S	8S	10S
FG ISO 500 314 001 003...	010	012	014	016	018	021	023	
W/RA/CA ISO 500 204 001 003...	010	012	014	016	018	021	023	027
W-Ig/RA-Ig/CA-Ig ISO 500 205 001 003...	010		014		018		023	027

Exkavieren
excavating
excavation
excavación

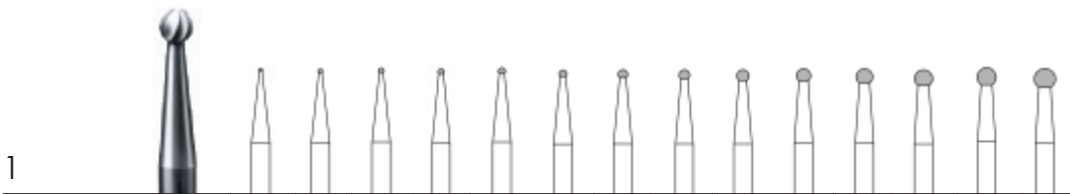

1

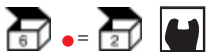

US-No	¼	½	¾	1	1 ½	2	3	4	5	6	7	8	9	10
FG ISO 500 314 001 001...	005	006	007	008	009	010	012	014	016	018	021	023		
W/RA/CA ISO 500 204 001 001...		006	007	008	009	010	012	014	016	018	021	023	025	027

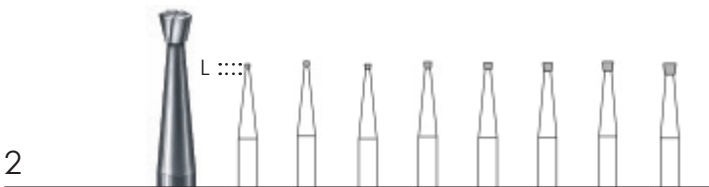

2



US-No	33 ½		34	34 ½	35	36	37	38
FG ISO 500 314 010 001...	006	007	008	009	010	012	014	016
W/RA/CA ISO 500 204 010 001...						012		
L mm	0,5	0,6	0,7	0,8	0,9	1,1	1,2	1,4

Hartmetall • Kavitäten- und Fissurenbohrer
 Carbide • Excavating and fissure burs
 Carbure • Fraises carbure pour cavités et fraises à fissures
 Carburo • Fresas de carburo para excavaciones y fisuras

Zahnmedizin
 Dentistry
 Odontologie
 Odontologia



7



US-No	330	331	332	333
FG	008	010	012	014
ISO 500 314 232 001...				
L mm	1,2	1,5	1,8	2,1



25R



US-No	331L	332L	333L
FG	010	012	014
ISO 500 314 238 006...			
L mm	4,0	4,5	4,5

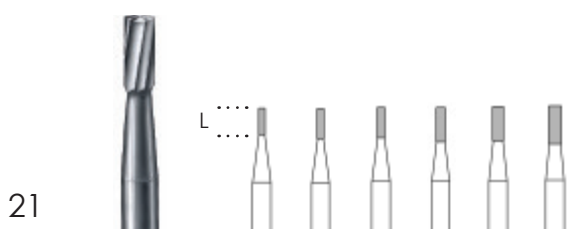

21



US-No	55	56	57	58	59	60
FG	008	009	010	012	014	016
ISO 500 314 107 006...						
W/RA/CA			010	012	014	
ISO 500 204 107 006...						
L mm	3,5	4,0	4,0	4,5	4,5	5,0



21R



US-No	1157	1158	1159
FG	010	012	014
ISO 500 314 137 006...			
L mm	4,0	4,5	4,5



21L



US-No	57L	58L
FG	010	012
ISO 500 314 110 006...		
L mm	5,5	6,0

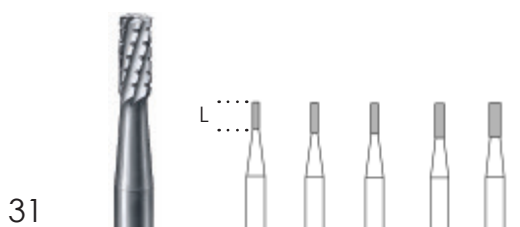

31



US-No	555	557	558	559	560
FG	008	010	012	014	016
ISO 500 314 107 007...					
L mm	3,5	4,0	4,5	4,5	5,0



Hartmetall • Kavitäten- und Fissurenbohrer

Carbide • Excavating and fissure burs

Carbure • Fraises carbure pour cavités et fraises à fissures

Carburo • Fresas de carburo para excavaciones y fisuras

31R

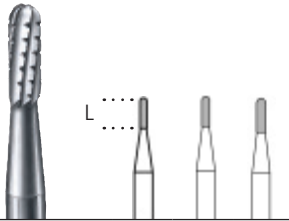

US-No	1557	1558	1559
FG	010	012	014
ISO 500 314 137 007...			
L mm	4,0	4,5	4,5

31L

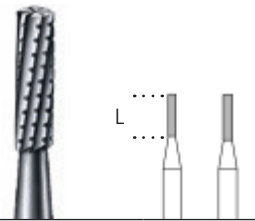

US-No	557L	558L
FG	010	012
ISO 500 314 110 007...		
L mm	5,5	6,0

23

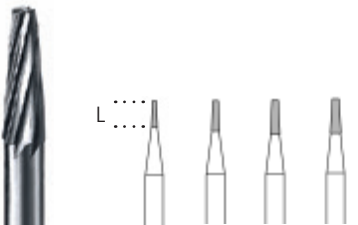

US-No	168	170	171	
FG	008	010	012	014
ISO 500 314 168 006...				
W/RA/CA				014
ISO 500 204 168 006...				
L mm	3,5	4,0	4,5	4,5

23R

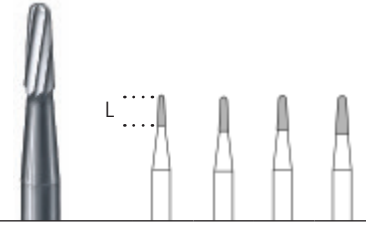

US-No	1170	1171		1172
FG	010	012	014	
ISO 500 314 194 006...				
W/RA/CA		012	014	016
ISO 500 204 194 006...				
L mm	4,0	4,5	4,5	5,0

zum minimal invasiven Aufziehen von Fissuren, schneidende Spitze
for minimal invasive opening of fissures, cutting tip

pour l'ouverture peu invasive des sillons, pointe coupante

para fijar fisuras y puntas agudas con una invasión mínima

23L

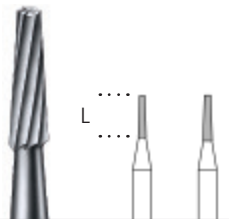

US-No	170L	171L
FG	010	012
ISO 500 314 171 006...		
L mm	5,5	6,0

23SR

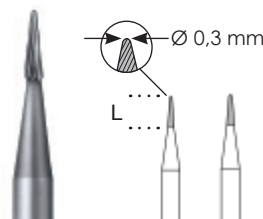

FG	008	010
ISO 500 314 196 006...		
L mm	4,0	4,0

59

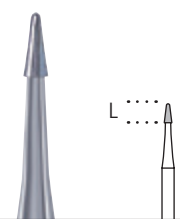

FG	010
ISO 500 314 207 072...	
L mm	2,5

Hartmetall • Kavitäten- und Fissurenbohrer
 Carbide • Excavating and fissure burs
 Carbure • Fraises carbure pour cavités et fraises à fissures
 Carburo • Fresas de carburo para excavaciones y fisuras

Zahnmedizin
 Dentistry
 Odontologie
 Odontologia

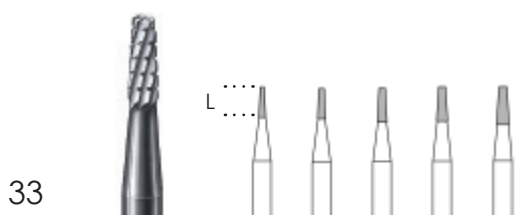

33



US-No	699	700	701		702
FG	009	010	012	014	016
ISO 500 314 168 007...					
W/RA/CA					016
ISO 500 204 168 007...					
L mm	4,0	4,0	4,5	4,5	5,0



33R



US-No	1700	1701	1702
W/RA/CA	010	012	016
ISO 500 204 194 007...			
L mm	4,0	4,5	5,0

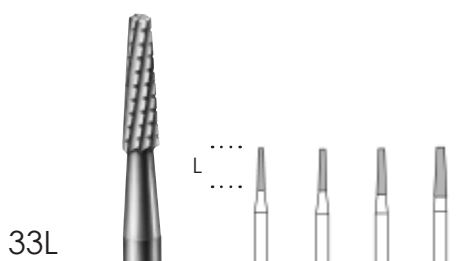

33L



US-No	699L	700L	701L	702L
FG	009	010	012	016
ISO 500 314 171 007...				
L mm	5,5	5,5	6,0	6,0



207



US-No	958
FG	012
ISO 500 314 150 001...	
L mm	6,5

Amalgamentferner
 amalgam remover
 pour le retrait des amalgames
 retirador de amalgama



32HG



FG	012
ISO 500 314 137 018...	
L mm	4,5

zügige Amalgamentfernung bei reduzierter Wärmeentwicklung
 fast removal of amalgam by reduction of heat development
 retrait rapide de l'amalgame lors d'une réduction de chaleur
 retirada rápida de amalgama con calorificación reducida

enamel shaver



400LRA



FG	014
ISO 500 314 218 001...	
L mm	7,5

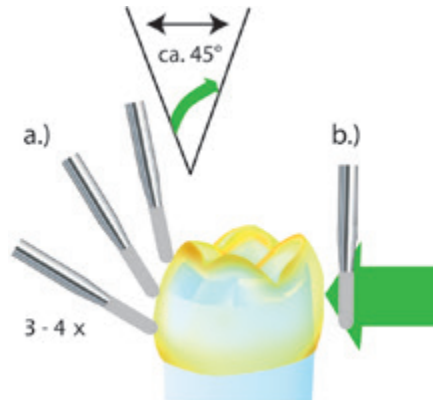



	Nicht Edelmetalle und deren Legierungen (NEM)	Hochgoldhaltige Edelmetall-Legierungen	Goldreduzierte Edelmetall-Legierungen	Verblendkeramik auf Metallgerüst	Zirkonoxid und Vollkeramik	Drehzahl-empfehlung
	NPM and their alloys métaux non précieux et leurs alliages (NEM) metales no preciosos y sus aleaciones	high gold content PM-alloys alliages des métaux précieux avec une haute teneur en or aleaciones de metales preciosos con alto contenido de oro	gold reduced PM-alloys alliages des métaux précieux avec une teneur réduite en or aleaciones de metales preciosos con bajo contenido de oro	PFM crowns (Porcelain fased to metal) céramique de recouvrement sur armature métallique cerámica de recubrimiento sobre estructura metálica	zirconia + full ceramic oxyde de zirconium + céramo-céramique óxido de zircónio + cerámica	recommended speed recommandation de vitesse de rotation velocidad recomendada
mit Diamantverzahnung with diamond cut avec denture diamant con dentado "diamante"	34D, 36RD, 38RD, 36RDL, 38RDL					180.000 - 200.000 min ⁻¹
ZIRAMANT- Kronentrenner crown cutters coupes-couronnes corta-coronas					6880Z 6855Z	140.000 - 160.000 min ⁻¹
mit Kreuzverzahnung with double cut avec denture croisée con dentado cruzado		21RX, 23RX				
mit feinem Querhieb with fine cross-cut avec taille transversale fine con corte transversal fino	34 36R 38R					180.000 - 200.000 min ⁻¹

Für das Auftrennen von Verblendkeramik kann alternativ ein Diamantschleifer mit grober Körnung verwendet werden.
Alternatively, a diamond bur with coarse grit can be used to cut the veneering ceramic.
Une fraise diamantée à gros grain peut également être utilisée pour couper la céramique de recouvrement.
Como alternativa, se puede utilizar una fresa de diamante de grano grueso para cortar la cerámica de recubrimiento.

mit Diamantverzahnung
 with diamond cut
 avec denture diamant
 con dentado diamante



34D

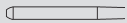

			
FG	010	012	
ISO 500 314 138 023...			
			
L mm	2,0	2,0	

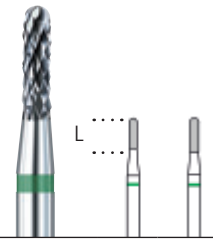

36RD

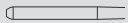

			
FG	010	012	
ISO 500 314 139 023...			
			
L mm	4,0	4,5	



38RD

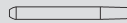

			
FG	010	012	
ISO 500 314 194 023...			
			
L mm	4,0	4,5	

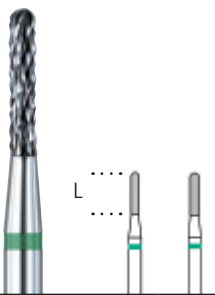

36RDL



			
FG	010	012	
ISO 500 314 140 023...			
			
L mm	5,6	5,6	

38RDL





			
FG	010	012	
ISO 500 314 197 023...			
			
L mm	5,6	5,6	

mit Spezialdiamantierung für Zirkonoxid und Vollkeramik
 with special diamond coating for zirconia and full ceramic
 avec diamantée spéciale pour oxyde de zirconium et céramo-céramique
 con recubrimiento diamantado especial para óxido de circonia y cerámica



6880Z



		
FG	014	
ISO 806 314 140 535...		
		
L mm	6,0	

6855Z



		
FG	014	
ISO 806 314 197 535...		
		
L mm	6,0	

ZIRAMANT Diamantschleifer
 ZIRAMANT Diamond Instruments
 Instruments diamantés ZIRAMANT
 Instrumentos diamantados ZIRAMANT

mit Kreuzverzahnung
 with double cut
 avec denture croisée
 con dentado cruzado



21RX

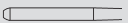

FG	010	012
ISO 500 314 140 019...		
		
L mm	5,6	5,6



23RX



FG	010	012
ISO 500 314 197 019...		
		
L mm	5,6	5,6

mit feinem Querhieb
 with fine cross-cut
 avec taille transversale fine
 con corte transversal fino



34



FG	010	012
ISO 500 314 138 293...		
		
L mm	2,0	2,0



36R



FG	010	012
ISO 500 314 139 293...		
		
L mm	4,0	4,5



38R



FG	010	012
ISO 500 314 196 293...		
		
L mm	4,0	4,5

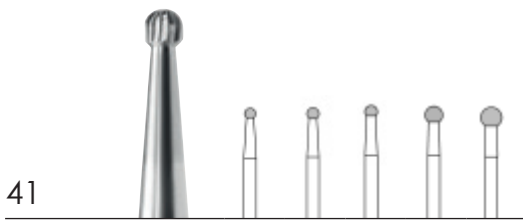

41

US-No	7004	7005	7006	7008	7009	
W/RA/CA	014	016	018	023	027	
ISO 500 204 001 071...						

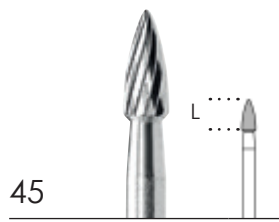

45

FG			018
ISO 500 314 274 072...			
W/RA/CA			018
ISO 500 204 274 072...			
L mm			4,0



44E

FG	014	018	023
ISO 500 314 277 072...			
W/RA/CA	014	018	023
ISO 500 204 277 072...			
L mm	2,9	3,5	4,2

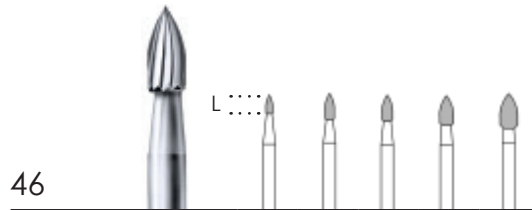

46

US-No		7102	7104	7106	7108
FG	009	012	014	018	023
ISO 500 314 254 072...					
W/RA/CA			014		
ISO 500 204 254 072...					
L mm	2,4	3,3	3,3	3,6	4,1

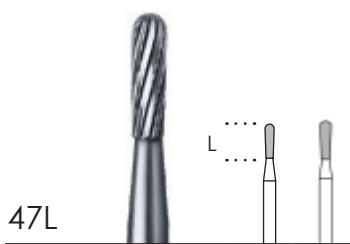

47L

US-No	7303	7304
FG	012	014
ISO 500 314 234 072...		
L mm	4,5	4,5



48

FG	009	010	012	014	
ISO 500 314 243 072...					
W/RA/CA				014	
ISO 500 204 243 072...					
L mm	3,4	3,5	3,5	4,0	

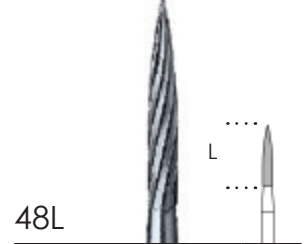

48L

FG		012
ISO 500 314 249 072...		
L mm		8,0



Hartmetall • Finierer
 Carbide • Finishing burs
 Carbure • Fraises à finir
 Carbuo • Fresas para acabado



50

FG	010
ISO 500 314 465 072...	
L mm	6,0

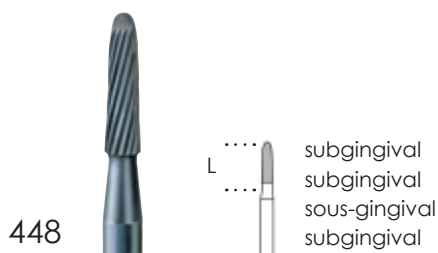

448

FG	014
ISO 500 314 215 072...	
L mm	6,0



332

FG	008
ISO 500 314 699 072...	
L mm	3,5



333

FG	010
ISO 500 314 159 072...	
L mm	4,2



334

FG	014
ISO 500 314 164 072...	
L mm	6,0



335

FG	014
ISO 500 314 166 072...	
L mm	9,0

243



 		
FG ISO 500 314 288 072...	010	012
		
W/RA/CA ISO 500 204 288 072...	010	012
		
L mm	6,0	6,0



244



 		
FG ISO 500 314 289 072...	012	014
		
W/RA/CA ISO 500 204 289 072...	012	
		
L mm	8,0	8,0



245



 		
FG ISO 500 314 290 072...	014	
		
L mm	10,0	

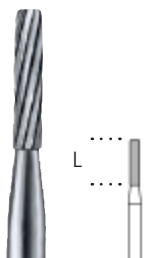

243KR

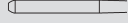

 	
FG ISO 500 314 157 072...	012
	
L mm	6,0

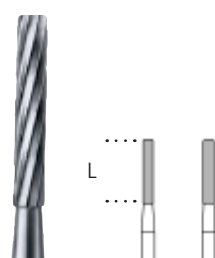
244KR

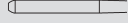

 		
FG ISO 500 314 158 072...	012	014
		
L mm	8,0	8,0

375R



  		
US-No	7675	7686
FG ISO 500 314 198 072...	016	018
		
L mm	8,0	8,0

243K

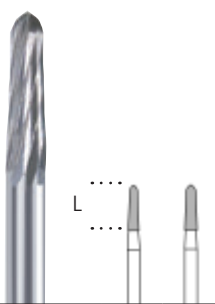

 		
FG ISO 500 314 297 072...	014	016
		
L mm	6,0	6,0

244K



 		
FG ISO 500 314 298 072...	014	016
		
L mm	8,0	8,0

245K



 			
FG ISO 500 314 299 072...	014	016	018
			
L mm	10,0	10,0	10,0

Feinverzahnung für Komposite und Metalle, gelber Ring, 16-22 Schneiden
 fine cut for composites and metals, yellow ring, 16-22 blades
 denture fine pour composites et métaux, bague jaune, 16-22 lames
 dentado fino para cara composites y metales, anillo amarillo, 16-22 filos



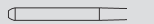
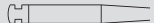

41F

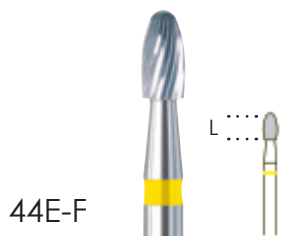
	
FG ISO 500 314 001 041...	018
	
W/RA/CA ISO 500 204 001 041...	018
	



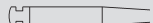

44E-F

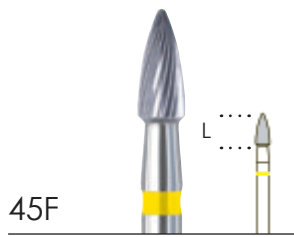
	
FG ISO 500 314 277 042...	018
	
W/RA/CA ISO 500 204 277 042...	018
	
L mm	3,5



45F

	
FG ISO 500 314 274 042...	018
	
W/RA/CA ISO 500 204 274 042...	018
	
L mm	4,0

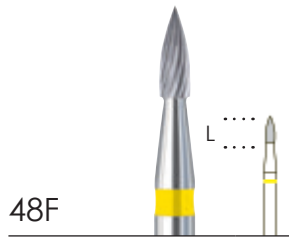

48F

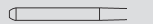
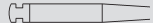
	
FG ISO 500 314 243 042...	012
	
W/RA/CA ISO 500 204 243 042...	012
	
L mm	3,5



48LF

	
FG ISO 500 314 249 042...	012
	
L mm	8,0

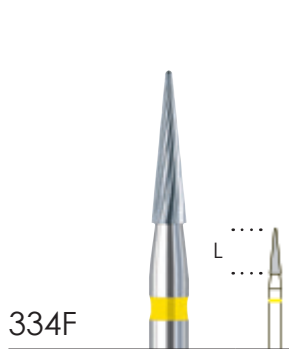

334F

	
FG ISO 500 314 164 042...	014
	
L mm	6,0



335F

	
FG ISO 500 314 166 042...	014
	
L mm	9,0

Hartmetall • Finierer
 Carbide • Finishing burs
 Carbure • Fraises à finir
 Carbuo • Fresas para acabado

Zahnmedizin
 Dentistry
 Odontologie
 Odontologia

ultra feine Verzahnung für Keramik und Komposit, weißer Ring, 30 Schneiden
 ultra fine cut for ceramic and composite, white ring, 30 blades
 denture ultra-fine pour céramique et composite, bague blanche, 30 lames
 dentado superfino para cerámica y composites, anillo blanco, 30 filos



44E-UF

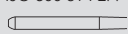

FG	018
ISO 500 314 277 032...	
	
L mm	3,5



45UF

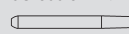

FG	018
ISO 500 314 274 032...	
	
L mm	4,0



48L-UF



FG	012
ISO 500 314 166 042...	
	
L mm	8,0



334UF



FG	014
ISO 500 314 164 031...	
	
L mm	6,0



335UF

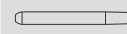

FG	014
ISO 500 314 166 031...	
	
L mm	9,0



406



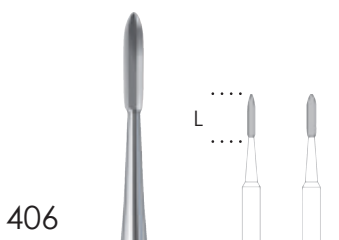

407L

- Schonende Beseitigung von supra- und subgingivalem Zahnstein bzw. Konkrementen.
- Wurzelreinigung und Wurzelglättung auch bei beginnender Furkationsbeteiligung.
- Odontoplastik, Beseitigung natürlicher Plaqueretentionsstellen.
- Glättung des Wurzelzementes bei parodontal geschädigten Zähnen.
- Vorreinigung der intraalveolären Knochentasche.
- Entfernung von Zementüberschüssen nach dem Einsetzen von festsitzendem Zahnersatz.
- Drehzahlempfehlungen bei Scaling-Einsatz 12.000 min⁻¹
Root-Planning-Einsatz 8.000 min⁻¹
- Sanfte Instrumentenführung unter leichtem Druck.
- Immer mit Kühlflüssigkeit arbeiten (je nach Einsatz Wasser-spray oder Kochsalzlösung).
- gentle removal of supra- and subgingival calculus respectively concretions.
- root cleaning and planing, also in bifurcation areas.
- odontoplastic, removal of natural plaque retention points.
- planing of root cementum of teeth with periodontal lesion.
- pre-cleaning of intraalveolar intrabony pocket.
- removal of cementum surplus after fitting of crowns and bridges.
- recommended speed for scaling 12.000 r.p.m.
root-planing 8.000 r.p.m.
- gentle instrument application with little pressure.
- always work with cooling liquid (either water-spray or saline).
- élimination avec ménagement, du tartre supragingival et sous gingival et d'autres dépôts.
- nettoyage et lissage des racines, même en cas de bifurcation initiale.
- dontoplastie, élimination des zones de rétention de plaque dentaire naturelles.
- lissage du ciment des racines de dents cariées dans la zone parodontale.
- pre-nettoyage d'une poche ultra-osseuse intra-alvéolaire.
- élimination des excédents de ciment après la mise en place des couronnes et bridges.
- vitesse recommandée détartrage 12.000 min⁻¹
polissage de la racine 8.000 min⁻¹
- maniement de l'instrument avec peu de pression.
- toujours utiliser un liquide de refroidissement (pulvérisation d'eau ou de solution isotonique salée).
- eliminación, de manera cuidadosa, del cálculo subgingival y supragingival, y de otras concreciones.
- limpieza y alisado de las raíces, incluso en caso de bifurcación inicial.
- odontoplásticas, eliminación de placas de retención naturales, odontoplásticas.
- alisado del cemento de las raíces de dientes deterioradas en el ámbito paradontal.
- limpieza previa de la bolsa infraósea.
- eliminación del cemento excesivo después de colocar coronas y puentes.
- trabajar con velocidad reducida, utilizando el contra-ángulo.
- velocidad recomendada detartraje 12.000 min⁻¹
alisado radicular 8.000 min⁻¹
- utilizar el instrumento de manera cuidadosa, con presión reducida.
- emplear siempre un líquido de enfriamiento (pulverización de agua o sal común el caso).



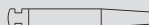

406

			
W/RA/CA	010	012	
ISO 500 204 267 381...			
			
L mm	5,8	5,8	

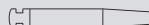

406L

			
W/RA/CA	010	012	
ISO 500 204 268 381...			
			
L mm	5,8	5,8	



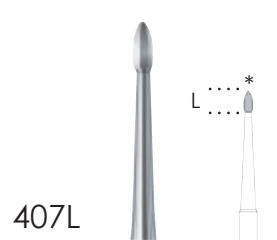

407

			
W/RA/CA		012	
ISO 500 204 258 381...			
			
L mm		2,9	

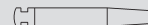

407L

			
W/RA/CA		012	
ISO 500 204 259 381...			
			
L mm		2,9	

* auch als Diamantschleifer erhältlich (Dia PERIO-PRO)
 * also available as diamond instrument (Dia PERIO-PRO)
 * également disponible en instrument diamanté (Dia PERIO-PRO)
 * también disponible como instrumento diamantado (Dia PERIO-PRO)

Hartmetall • Chirurgie-Instrumente, Knochenfräser
 Carbide • Surgical instruments, bone cutters
 Carbure • Instruments chirurgicaux, fraises à os
 Carbuo • Fresas para cirugía, fresas para huesos

Zahnmedizin
 Dentistry
 Odontologie
 Odontologia

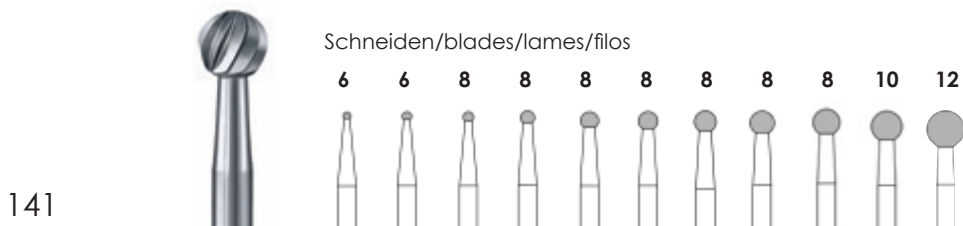

141



H/HP/PM ISO 500 104 001 291...	010	012	014	018	023	025	027	031	035	040	050
W lg/RA lg/CA lg ISO 500 205 001 291...							027	031	035	040	050
W x-lg/RA x-lg/CA x-lg ISO 500 206 001 291...			014	018	023		027	031	035		
FG x-lg ISO 500 316 001 291...	010	012	014	018	023						

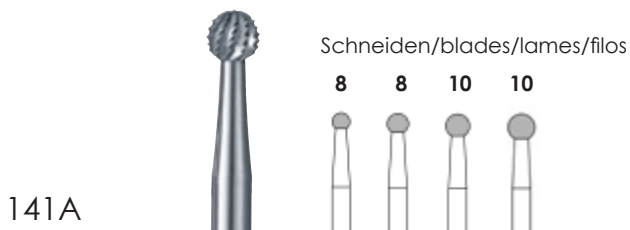

141A



H/HP/PM ISO 500 104 001 298...	023	027	031	035
W lg/RA lg/CA lg ISO 500 205 001 298...	023	027	031	035
W x-lg/RA x-lg/CA x-lg ISO 500 206 001 298...	023	027	031	035

Knochenfräser mit A-Verzahnung für die schonende, vibrationsarme Behandlung
 bone cutters with A-cut for a gentle, and low vibration treatment

fraise à os avec denture A pour un traitement plus atraumatique et avec peu de vibrations

fresa para huesos con dentadura A para un tratamiento más cuidadosa y con poca vibración

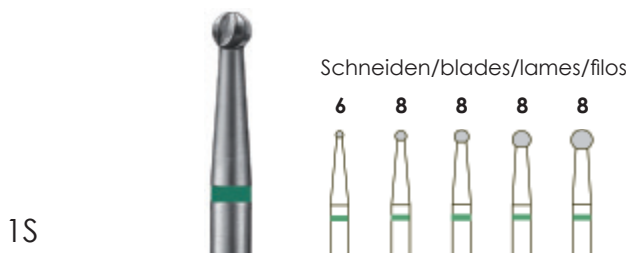

1S



US-No	2S	4S	6S	8S	10S
W lg/RA lg/CA lg ISO 500 205 001 003...	010	014	018	023	027

schnitffreudige Verzahnung, grüner Ring
 power cut, green ring

denture particulièrement sécante, bague verte
 dentado de alto rendimiento, anillo verde

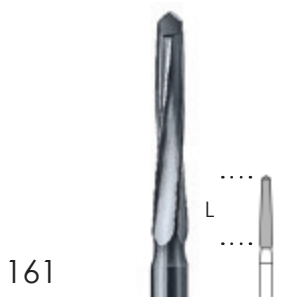

161

		
FG	ISO 500 314 408 295...	016
L mm		9,0



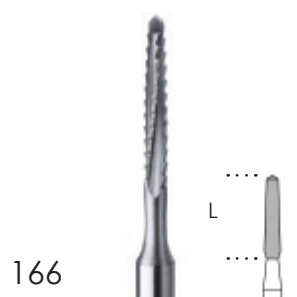

162

		
FG	ISO 500 314 408 297...	016
H/HP/PM	ISO 500 104 408 297...	016
W/RA/CA	ISO 500 204 408 297...	016
W Ig/RA Ig/CA Ig	ISO 500 205 408 297...	016
L mm		9,0



166

		
H/HP/PM	ISO 500 104 409 297...	021
W/RA/CA	ISO 500 204 409 297...	021
W Ig/RA Ig/CA Ig	ISO 500 205 409 297...	021
L mm		10,0

Knochenfräser mit A-Verzahnung für schonendes Zerspanen und feinere Oberflächen
 bone cutters with A-cut for a gentle chip removal and finer surface
 fraises à os avec denture A pour un soigneux enlèvement des copeaux et une surface lisse
 fresa para huesos con dentado A para arrancar cuidadosamente las virutas y finas superficies

Knochenfräser mit A-Verzahnung für minimalinvasives, schonendes Präparieren von Knochengewebe und Zahnhartsubstanz
 bone cutters with A-cut for a minimal invasive and gentle preparation of bone tissue and hard tooth substance
 fraises à os avec denture A pour un préparation minimalinvasif et soigneux du tissu osseux et de la substance dentaire dure
 fresa para huesos con dentado A para preparación invasiva minimal y cuidadosamente del tejido de hueso y de la sustancia dura de dientes





162A

		
FG	ISO 500 314 408 298...	016
H/HP/PM	ISO 500 104 408 298...	016
W/RA/CA	ISO 500 204 408 298...	016
W Ig/RA Ig/CA Ig	ISO 500 205 408 298...	016
L mm		9,0



166A

		
H/HP/PM	ISO 500 104 409 298...	021
W/RA/CA	ISO 500 204 409 298...	021
W Ig/RA Ig/CA Ig	ISO 500 205 409 298...	021
L mm		10,0

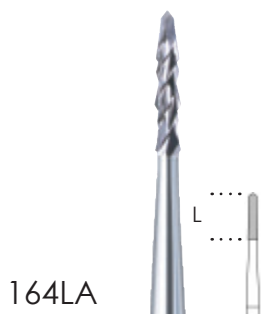

164LA

		
FG	ISO 500 314 415 298...	012
L mm		6,5

Hartmetall • Chirurgie-Instrumente, Knochenfräser, Endo Erweiterer
 Carbide • Surgical instruments, bone cutters, Endo reamer
 Carbure • Instruments chirurgicaux, fraises à os, Endo élargisseurs
 Carbuo • Fresas para cirugía, fresas para huesos, Endo (ampliación del canal)

Zahnmedizin
 Dentistry
 Odontologie
 Odontologia



267

FG ISO 500 314 210 295...	016
H/HP/PM ISO 500 104 210 295...	016
W/RA/CA ISO 500 204 210 295...	016
L mm	9,0

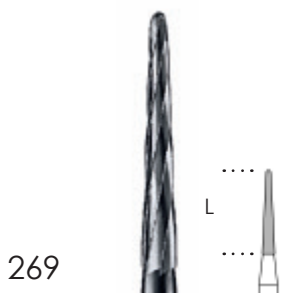

269

FG ISO 500 314 199 295...	016
H/HP/PM ISO 500 104 199 295...	016
W/RA/CA ISO 500 204 199 295...	016
L mm	11,0



31RL

US-No	557X	558X
FG x-Ig	010	012
ISO 500 316 140 007...		
L mm	5,5	6,0



33RL

US-No	701X	702X	703X
FG x-Ig	014	016	018
ISO 500 316 197 007...			
H Ig/HP Ig/PM Ig	014		
ISO 500 105 197 007...			
L mm	6,0	6,5	6,5



700XXL

FG ISO 500 314 415 296...	011
L mm	5,0



152Z

FG ISO 500 314 219 295 ...	015
L mm	9,0

Endo Erweiterer
 endo reamer
 endo élargisseurs
 endo (ampliación del canal)

Zahnmedizin





Dentistry • Odontologie • Odontologia



Stahl

Steel • Acier • Acero

Anwendungsbeispiele Examples of application Exemples d'application Ejemplos de aplicaciones	58
Kavitäten-Bohrer Excavating burs Fraises pour cavités Fresas excavadoras	59
Finierer, Prophylaxe-Instrumente Finishing burs, prophylaxis instruments Fraises à finir, instruments prophylactiques Fresas de acabar, instrumentos profilácticos	60
Chirurgie-Instrumente Surgical instruments Instruments chirurgicaux Instrumentos quirúrgicos	61

Einsatzgebiet Zahnmedizin used in the denistry domaine d'applicat. odontologie uso en sector odontológico	Instrumentenbeispiel examples of instruments exempl. d'instruments ej. de los instrumentos	ISO-Ø	empfohlene Drehzahl min ⁻¹ recommended speed r.p.m. vitesse de rotation rec. velocidad recomendada
Exkavieren von kariösem Dentin excavating of carious dentine excavation de la dentine carieuse excavación de dentina cariado	1 	005-010 012-016 018-021 023-031	3.000 - 1.000 2.800 - 750 1.600 - 500 1.000 - 500
Finieren finishing finissage acabado	41 	010-014 016-023	30.000 - 5.000 15.000 - 5.000
Zahnstein entfernen removing tartar Enlever le tartre para separar el tártaro	402 	009-016	300.000 - 140.000
Zerspanen von Knochenmaterial cutting of bones trépanation d'os taladro del material de hueso	1RS H/HP/PM 	005-023	5.000 - 500
	162RS FG 	016	65.000 - 15.000

Stahl • Kavitäten-Bohrer
 Steel • Excavating burs
 Acier • Fraises pour cavités
 Acero • Fresas excavadoras

Zahnmedizin
 Dentistry
 Odontologie
 Odontologia

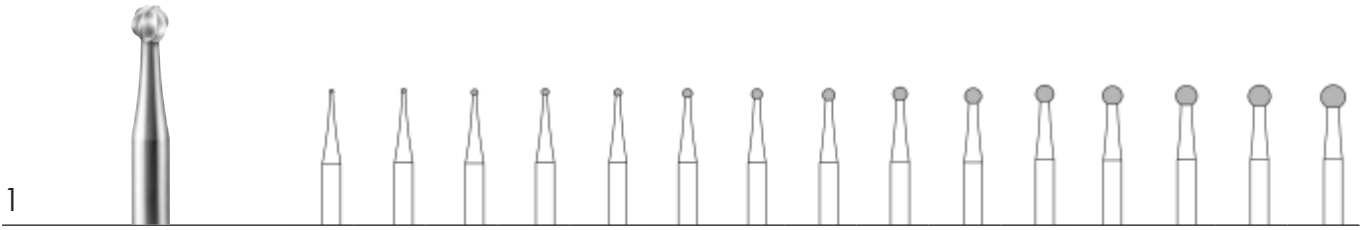

US-No	¼	½	1	1½	2	3	4	5	6	7	8	9	10	11	
W/RA/CA ISO 310 204 001 001...	005	006	008	009	010	012	014	016	018	021	023	025	027	029	031
W lg/RA lg/CA lg ISO 310 205 001 001...					010	012	014	016	018	021	023				

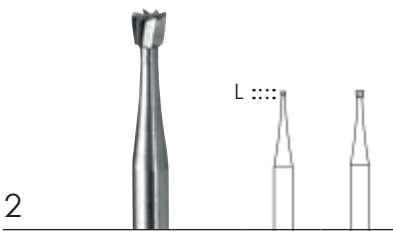

US-No	33 ½	35
W/RA/CA ISO 310 204 011 001...	006	010
L mm	0,53	0,88

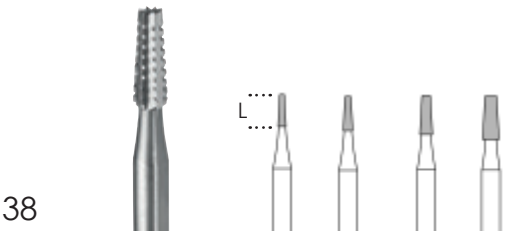

US-No	700	701	702	703
W/RA/CA ISO 310 204 168 002...	010	012	016	021
L mm	4,2	4,5	5,1	5,7

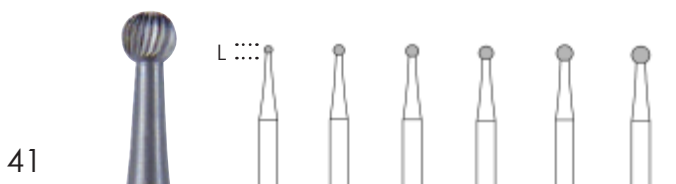

41



US-No	7002	7004	7005	7006		7008
W/RA/CA	010	014	016	018	021	023
ISO 310 204 001 071...						
L mm	1,0	1,4	1,4	1,6	1,8	2,3



47



W/RA/CA	014	018
ISO 310 204 237 071...		
L mm	1,7	2,2

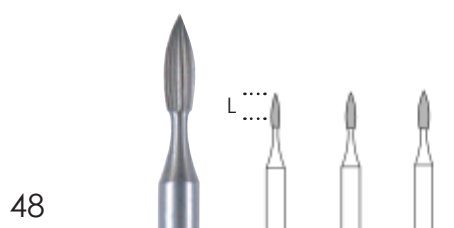

48



US-No.	242		
W/RA/CA	010	012	014
ISO 310 204 243 071...			
L mm	4,4	4,7	5,0

ROTO-PRO Zahnsteinentferner

ROTO-PRO calculus remover

ROTO-PRO detartreur

ROTO-PRO para separar el tártaro

Polygonales Arbeitsteil ohne scharfe Schneiden, anwendbar in der konservierenden Zahnheilkunde, Prothetik, Kieferorthopädie und Parodontologie. Drehzahl 140.000 – 300.000 min⁻¹.

parte travaillante pourvue de polygonal sans lames coupantes, applicable à l'odontologie conservatrice, prothèse dentaire, orthodontie et parodontologie. vitesse 140.000 – 300.000 tours/min.

Polygonal working part without sharp edges, applicable in restorative dentistry, fixed prosthodontics, orthodontics and periodontics. speed 140.000 – 300.000 rpm.

Parte de trabajo provista polygonal, sin cortantes vivos. aplicable en odontología de restauración, prótesis dental, ortodoncía y parodontología. velocidad 140.000 – 300.000 revol./min.

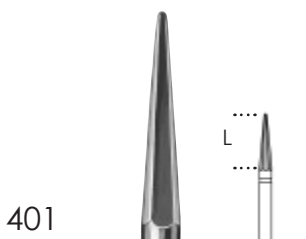

401



FG	016
ISO 310 314 470 381...	
L mm	7,5

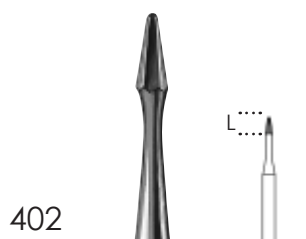

402



FG	009
ISO 310 314 469 381...	
L mm	2,2

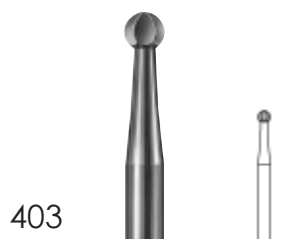

403



FG	016
ISO 310 314 001 381...	
L mm	



404



FG	016
ISO 310 314 243 381...	
L mm	5,2

Knochenfräser für die Chirurgie
 bone Cutters for Oral Surgery
 fraises à os chirurgicales
 fresas para huesos quirúrgicos

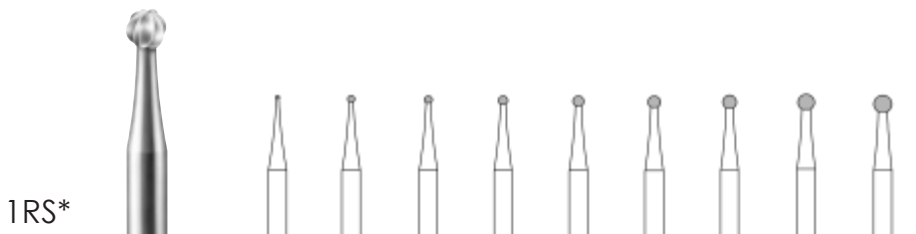

1RS*



US-No	¼ RS	1½RS	2RS	3RS	4RS	5RS	6RS	7RS	8RS
H/HP/PM ISO 330 104 001 001...	005	009	010	012	014	016	018	021	023

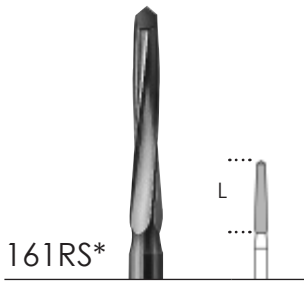

161RS*



FG ISO 330 314 408 295...	016
L mm	9,0

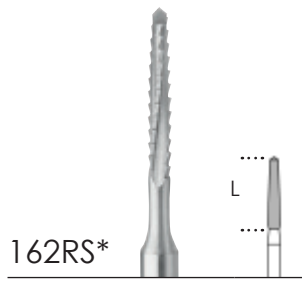

162RS*



FG ISO 330 314 408 297...	016
L mm	9,0

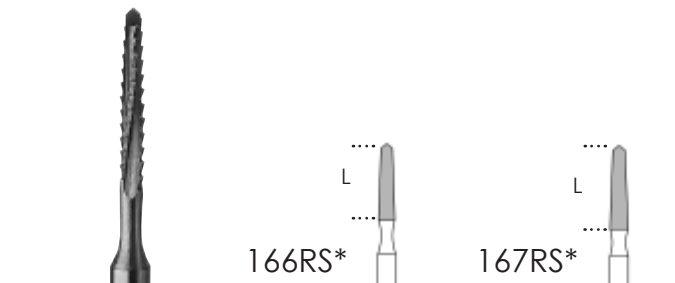

166RS*

167RS*



H/HP/PM ISO 330...	021 409 297 021	023 410 297 023
L mm	10,0	11,0

Zahnmedizin

Dentistry • Odontologie • Odontologia

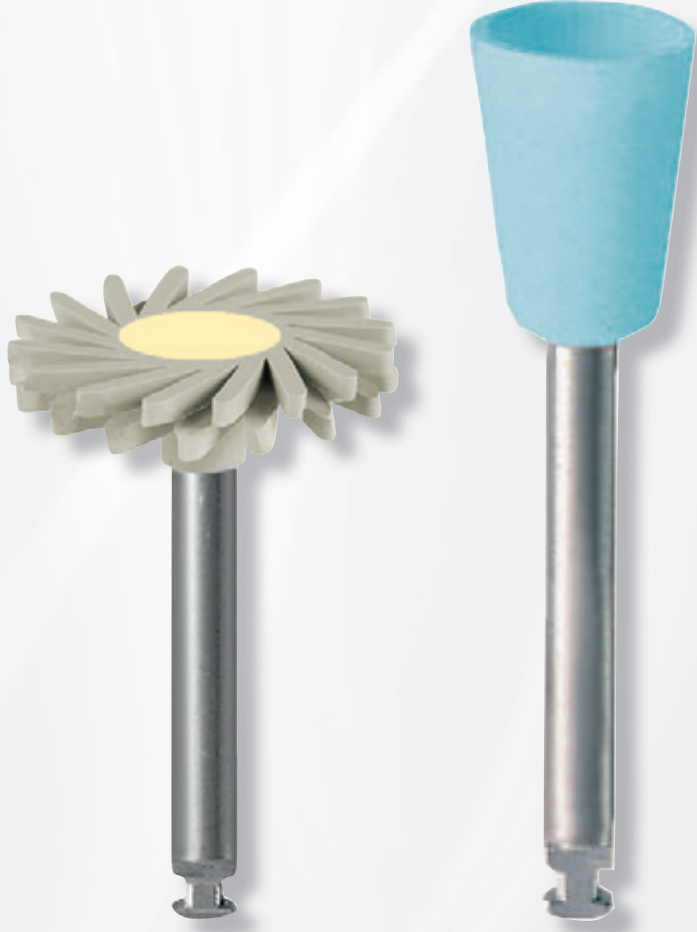

Polierer

Polishers • Polissoirs • Pulidores

Universalvorpolyer für alle Restaurationsmaterialien Universal pre-polishers, for all restoration materials Pré-polissoirs universels pour tous matériels de restauration Pulidores universales para todos los materiales de restauraciones	64
2-stufiges diamantdurchsetztes Poliersystem für (auch hochgefüllte) Komposite 2-step diamond interspersed polishing system for composite (also high filled) Système de polissage en 2 étapes des diamants pour composites (aussi les fortement chargés) Sistema de pulimento en 2 etapas con diamantes para composites (también con proporciones elevadas)	65
2-stufiges Poliersystem für Komposite 2-step polishing system for composite Système de polissage en 2 étapes pour composites Sistema de pulimento en 2 etapas para composites	66
2-stufiges Poliersystem für Edelmetall-Legierungen, NEM und Amalgam 2-step polishing system for precious and non-precious metal alloys, amalgam Système de polissage en 2 étapes pour alliages de métaux précieux, non précieux et amalgame Sistema de pulimento en 2 etapas para aleaciones de metales preciosos y non-preciosos, amalgama	67
2-stufiges diamantdurchsetztes Poliersystem für Keramik/Silikatkeramik 2-step diamond interspersed polishing system for ceramics/silicate ceramics Système de polissage en 2 étapes imprégné de diamant pour la céramique/céramique silicatée Sistema de pulimento en 2 etapas impregnado de diamante para cerámica/cerámica de silicatos	68
2-stufiges diamantdurchsetztes Poliersystem für Zirkonoxid 2-step diamond interspersed polishing system for zirconia Système de polissage en 2 étapes imprégné de diamant pour l'oxyde de zirconie Sistema de pulimento en 2 etapas impregnado de diamante para dióxido de circonio	69
Polierbürsten für Restaurationen Polishing brush for restorations Brosses à polissage pour les restaurations Cepillo para el pulido de restauraciones	70
Soft Disc/4-stufiges Polierscheibensystem für Gold, Komposite und Amalgam Soft disc/4 step polishing disc system for gold, composite and amalgam Soft disque/système de disque de polissage en 4 étapes pour l'or, composite et amalgame Soft Disc/Sistema de discos de pulimento en 4 etapas para oro, composites y amalgama	71
Polierer für die Prophylaxe Polishers for prophylaxis Polissoirs pour la prophylaxie Pulidores para profilaxia	72
Bürsten für die Prophylaxe Brushes for prophylaxis Brosses pour la prophylaxie Cepillos para profilaxia	73



Polierer
Polishers
Polissoirs
Pulidores

Universalvorpolyer für alle Restaurationsmaterialien

Universal pre-polishers, for all restoration materials

Pré-polissoirs universels pour tous matériels de restauration

Pulidores universales para todos los materiales de restauraciones

Vorpolitur, weiß

Siliziumkarbid (SiC), Silicon,
Korngröße grob
Bindungshärte weich

pre-polishing, white

silicon carbide (SiC),
silicon, grit size coarse
bond hardness soft

prépolissage, blanc

carbure de silicium (SiC),
silicone, taille de grain gros
dureté de liaison doux

prepulimento, blanco

carburo de silicio (SiC), silicon,
tamaño de grano grueso
dureza de ligazón blanda

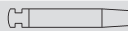

 W/RA/CA ISO 658 204 ...	9607G/070 030 523 070	9608G/030 297 523 030	9609G/050 243 523 050
L mm	10,0	7,5	10,0



2-stufiges diamantdurchsetztes Poliersystem für (auch hochgefüllte) Komposite
2-step diamond interspersed polishing system for composite (also high filled)
Système de polissage en 2 étapes imprégné de diamant pour composites (aussi les fortement chargés)
Sistema de pulimento en 2 etapas impregnado de diamante para composites (también con proporciones elevadas)

Vorpolitur, rosa beige

Diamant, PUR
Korngröße mittel
Bindungshärte mittel

pre-polishing, pink beige

diamond, PUR
grit size medium
bond hardness medium

prépolissage, rose beige

diamant, PUR
taille de grain moyen
dureté de liaison moyen

prepulimento, rosa beige

diamante, PUR
tamaño de grano medio
goma de dureza media

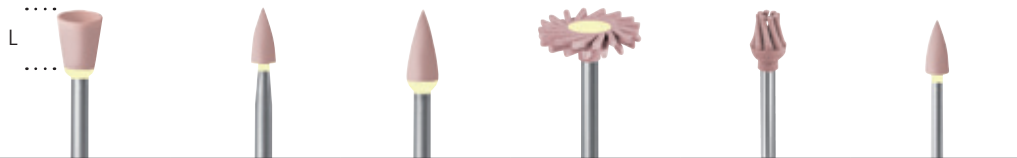

FG ISO 803 314 ...						9588/030 243 523 030
W/RA/CA ISO 803 204 ...	9587/060 030 523 060	9588/030 297 523 030	9589/040 243 523 040	9591/140 543 523 140	9583/055 000 523 055	
L mm	7,5	7,5	10,0	1,6	8,8	6,5

Hochglanzpolitur,
hellgrau beige

Diamant, PUR
Korngröße fein
Bindungshärte mittel

high shine polishing,
grey beige

diamond, PUR
grit size fine
bond hardness medium

polissage brillant,
gris clair beige

diamant, PUR
taille de grain fin
dureté de liaison moyen

pulimento de brillo,
gris claro beige

diamante, PUR
tamaño de grano fino
goma de dureza media

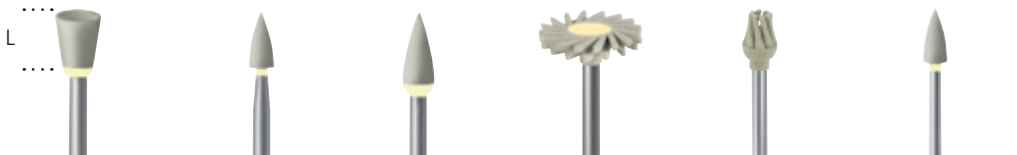

FG ISO 803 314 ...						9578/030 243 503 030
W/RA/CA ISO 803 204 ...	9577/060 030 503 060	9578/030 297 503 030	9579/040 243 503 040	9581/140 543 503 140	9593/055 000 503 055	
L mm	7,5	7,5	10,0	1,6	8,8	6,5



diamantdurchsetzt/diamond interspersed/imprégné de diamant/impregnado de diamante

2-stufiges Poliersystem für Komposite

2-step polishing system for composite

Système de polissage en 2 étapes pour composites

Sistema de pulimento en 2 etapas para composites

Vorpolitur, gelb

Edelkorund (Al_2O_3),
Silikon
Korngröße mittel
Bindungshärte weich

Auch zur Entfernung von
Klebstoffresten nach der
Bracketentfernung geeignet.

pre-polishing, yellow

high-grade corundum (Al_2O_3),
silicon
bond grit size medium
bond hardness soft

Also suitable for the removal
of adhesive residues after
bracket treatment.

prépolissage, jaune

corindon affiné (Al_2O_3),
liaison silicone
taille de grain moyen
dureté de liaison doux

Aussi approprié pour
enlèvement des restes
d'adhésif après le traitement
de brackets.

prepulido, amarillo

corindon fino (Al_2O_3), silicona
tamaño de grano mediano
dureza de ligazón blanda

También adecuado para la
eliminación de restos de adhesi-
vos después de quitar brackets.

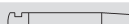

 W/RA/CA ISO 658 204 ...	9667/070 030 522 070	9668/030 297 522 030	9669/050 243 522 050
L mm	10,0	7,5	10,0

Glanzpolitur, blau

Edelkorund (Al_2O_3),
Silikon
Korngröße fein
Bindungshärte weich

shine-polishing, blue

high-grade corundum (Al_2O_3),
silicone bond
grit size fine
bond hardness soft

polissage brillant, bleu

corindon affiné (Al_2O_3),
liaison silicone
taille de grain fin
dureté de liaison doux

pulimento de brillo, azul

corindon fino (Al_2O_3),
ligazón silicona
tamaño de grano fino
dureza de ligazón blanda

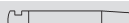

 W/RA/CA ISO 658 204 ...	9677/070 030 512 070	9678/030 297 512 030	9679/050 243 512 050
L mm	10,0	7,5	10,0

2-stufiges Poliersystem für Edelmetall-Legierungen, NEM und Amalgam
2-step polishing system for precious and non-precious metal alloys, amalgam
Système de polissage en 2 étapes pour alliages de métaux précieux, non précieux et amalgame
Sistema de pulimento en 2 etapas para aleaciones de metales preciosos y non-preciosos, amalgama

Vorpolitur, braun

Siliziumkarbid (SiC), PUR
Korngröße mittel
Bindungshärte mittel

pre-polishing, brown

silicon carbide (SiC), PUR
grit size medium
bond hardness medium

prépolissage, marron

carbure de silicium (SiC), PUR
taille de grain moyen
dureté de liaison moyen

prepulido, marrón

carburo de silicio (SiC), PUR
tamaño de grano medio
dureza de ligazón media

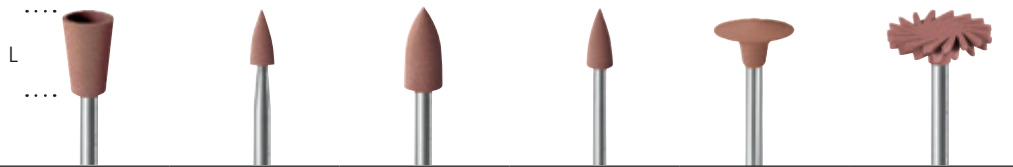

FG ISO 653 314 ...				9608/030 243 513 030		
W/RA/CA ISO 653 204 ...	9607/065 030 513 065	9608/030 297 513 030	9609/050 243 513 050		9604/100 304 513 100	9611/140 543 513 140
L mm	9,5	7,5	10,0	6,5	2,4	1,6

Glanzpolitur, grün

Siliziumkarbid (SiC), PUR
Korngröße fein
Bindungshärte weich

shine-polishing, green

silicon carbide (SiC), PUR
grit size fine
bond hardness soft

polissage brillant, vert

carbure de silicium (SiC), PUR
taille de grain fin
dureté de liaison doux

pulido brillante, verde

carburo de silicio (SiC), PUR
tamaño de grano fino
dureza de ligazón blanda



FG ISO 653 314 ...				9618/030 243 503 030	
W/RA/CA ISO 653 204 ...	9617/065 030 503 065	9618/030 297 503 030	9619/050 243 503 050		9621/140 543 503 140
L mm	9,5	7,5	10,0	6,5	1,6



2-stufiges diamantdurchsetztes Poliersystem für Keramik/Silikatkeramik
 2-step diamond interspersed polishing system for ceramics/silicate ceramics
 Système de polissage en 2 étapes imprégné de diamant pour la céramique/céramique silicatée
 Sistema de pulimento en 2 etapas impregnado de diamante para cerámica/cerámica de silicatos

Vorpolitur, rot gelb

Diamant, PUR
Korngröße mittel
Bindungshärte weich

pre-polishing, red yellow

diamond, PUR
grit size medium
bond hardness soft

prépolissage, rouge jaune

diamant, PUR
taille de grain moyen
dureté de liaison doux

prepulido, rojo amarillo

diamante, PUR
tamaño de grano mediano
dureza de ligazón blanda



				
W/RA/CA ISO 803 204 ...	9807/060 030 523 060	9808/030 297 523 030	9809/040 243 523 040	9811/140 543 523 140
L mm	7,5	7,5	10,0	1,6

**Glanzpolitur,
grün gelb**

Diamant, PUR
Korngröße fein
Bindungshärte weich

**shine-polishing,
green yellow**

diamond, PUR
grit size fine
bond hardness soft

**polissage brillant,
vert jaune**

diamant, PUR
taille de grain fin
dureté de liaison doux

**pulido brillante,
verde amarillo**

diamante, PUR
tamaño de grano fino
dureza de ligazón blanda

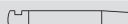

				
W/RA/CA ISO 803 204 ...	9817/060 030 513 060	9818/030 297 513 030	9819/040 243 513 040	9821/140 543 513 140
L mm	7,5	7,5	10,0	1,6



diamantdurchsetzt/diamond interspersed/imprégné de diamant/impregnado de diamante



2-stufiges diamantdurchsetztes Poliersystem für Zirkonoxid

2-step diamond interspersed polishing system for zirconia

Système de polissage en 2 étapes imprégné de diamant pour l'oxyde de zirconie

Sistema de pulimento en 2 etapas impregnado de diamante para dióxido de circonio

Vorpolitur, türkis gelb

Diamant, PUR
Korngröße mittel
Bindungshärte mittel

pre-polishing, turquoise yellow

diamond, PUR
grit size medium
bond hardness medium

prépolissage, turquoise jaune

diamant, PUR
taille de grain moyen
dureté de liaison moyen

prepulido, turquesa amarillo

diamante, PUR
tamaño de grano mediano
dureza de ligazón mediana

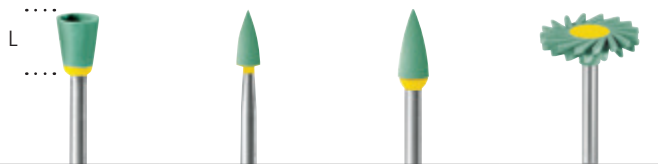

W/RA/CA ISO 803 204 ...	9907/060 030 524 060	9908/030 297 524 030	9909/040 243 524 040	9911/140 543 524 140	
L mm	7,5	7,5	10,0	1,6	

Hochglanzpolitur, rosa gelb

Diamant, PUR
Korngröße fein
Bindungshärte mittel

high shine-polishing, pink yellow

diamond, PUR
grit size fine
bond hardness medium

polissage haute
brillance rose jaune

diamant, PUR
taille de grain fin
dureté de liaison moyen

pulido de alto brillo,
rosa amarillo

diamante, PUR
tamaño de grano fino
dureza de ligazón mediana

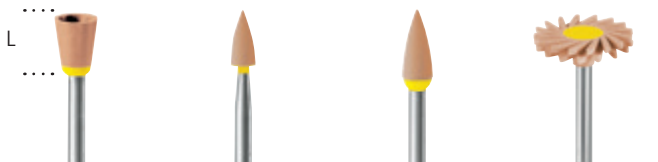

W/RA/CA ISO 803 204 ...	9917/060 030 514 060	9918/030 297 514 030	9919/040 243 514 040	9921/140 543 514 140	
L mm	7,5	7,5	10,0	1,6	



diamantdurchsetzt/diamond interspersed/imprégné de diamant/impregnado de diamante



Polierer
Polishers
Polissoirs
Pulidores

Polierbürsten für Restaurationen

Polishing brush for restorations

Brosses à polissage pour les restaurations

Cepillo para el pulido de restauraciones

SIC Brush

Spezialbürste für die Politur von Restaurationen aus Keramik, Komposite und Metall

special brush for polishing restorations made from ceramic, composite and metals

brosses spéciales pour le polissage des restaurations du céramique des composites et métaux

cepillo especial para el pulido de restauraciones de cerámica, e composites y de metales

für die Anwendung
ohne Polierpaste,
beige

Siliziumkarbid (SiC),
Polyamid
Korngröße fein

for the application without
polishing paste, beige

silicon carbide (SiC),
polyamide
grit size fine

pour l'application
sans pâte à polir,
beige

carbure de silicium (SiC),
polyamide
taille de grain fin

para aplicación
sin pasta de pulir,
beige

carburo de silicio (SiC),
polyamid
tamaño de grano fino

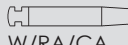

 W/RA/CA ISO 655 204 ...	9735SiC/060 010 504 060	9730SiC/040 010 504 040	9731SiC/040 131 504 040
L mm	5,5	6,5	6,5

Soft Disc/4-stufiges Polierscheibensystem für Gold, Komposite und Amalgam

Soft disc/4step polishing disc system for gold, composite and amalgam

Soft disque/système de disque de polissage en 4 étapes pour l'or, composite et amalgame

Soft disc/sistema de discos de pulimento en 4 etapas para oro, composites y amalgama

Soft Disc

Edelkorund (Al₂O₃),
einseitig, Polyester
flexibel

Soft Disc

corundum (Al₂O₃),
single side, polyester
flexible



Soft Disc

corindon affiné (Al₂O₃),
d'un côté, polyester
flexible

Soft Disc

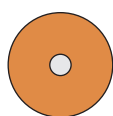
corindon fino (Al₂O₃),
unilateralmente, poliéster
flexible



Größe 100 diameter 100 taille 100 tamaño 100 ISO 620 900		9590G/100 371 531 100	9590M/100 371 521 100	9590F/100 371 511 100	9590EF/100 371 501 100
Größe 140 diameter 140 taille 140 tamaño 140 ISO 620 900		9590G/140 371 531 140	9590M/140 371 521 140	9590F/140 371 511 140	9590EF/140 371 501 140
Farbe colour couleur color		rost red rouille óxido	orange orange orange naranja	hellorange light orange orange clair naranja claro	gelb yellow jaune amarillo
Korngröße grit size taille de grain grano		grob coarse gros grueso	mittel medium moyen mediano	fein fine fin fino	extra fein extra fine extra fin extra fino
Arbeitsgang step		Glätten smoothing	Vorpolitur pre-polishing	Glanzpolitur high lustre polishing	Hochglanz super high lustre polishing
phase de travail		lissage	prépolissage	polissage brillant	polissage bril- lant supérieure
fase de trabajo		alisado	prepulimento	pulimento de brillo	pulimento de brillo intenso

Soft Disc Träger
Soft Disc mandrel
Soft Disc mandrin
mandril Soft Disc



 W/RA/CA ISO 330 204 ...	312RS Wst 608 000 035
---	--------------------------

Soft Disc Set



Inhalt: **9590/100 Set** = 25 Scheiben je Körnung, Größe 100
9590/140 Set = 25 Scheiben je Körnung, Größe 140
inklusive 1 Träger 312RS

content: **9590/100 Set** = 25 disc per grit size, diameter 100
9590/140 Set = 25 disc per grit size, diameter 140
inclusive 1 mandrel 312RS

contenu: **9590/100 Set** = 25 disques par grain, taille 100
9590/140 Set = 25 disques par grain, taille 140
inclus 1 mandrin 312RS

contenido: **9590/100 Set** = 25 discos por grano, tamaño 100
9590/140 Set = 25 discos por grano, tamaño 140
incl. 1 mandril 312RS



Polierer für die Prophylaxe
 Polishers for prophylaxis
 Polissoirs pour la prophylaxie
 Pulidores para profilaxia

für die Anwendung
 mit Polierpaste,
 weiß

Silikonpolierer
 (ohne Schleifkorn)
 Bindungshärte mittel

for the application with
 polishing paste,
 white

silicone polisher
 (without abrasive grain)
 bond hardness medium

pour l'application avec
 pâte à polir,
 blanc

polissoir en silicone
 (sans grain abrasif)
 dureté de liaison moyen

para aplicación con pasta
 de pulir,
 blanco

pulidores de silicona
 (sin grano abrasivo)
 dureza de la ligazón media



W/RA/CA ISO 008 204 ...	9631/060 034 003 060
L mm	10,0

Einmalinstrument
 single use instrument
 usage unique
 usar una vez

für die Anwendung
 ohne Polierpaste,
 grün

BIMS PUR,
 Korngröße fein

for the application
 without polishing paste,
 green

pumice PUR,
 grit size fine

pour l'application sans
 pâte à polir,
 vert

BIMS PUR,
 taille de grain fin

para aplicación
 sin pasta de pulir,
 verde

BIMS PUR,
 tamaño de grano fino



W/RA/CA ISO 653 204 ...	9633S/070 034 512 070
L mm	10,0

Einmalinstrument/Kunststoffschaft
 single use instrument/plastic shank
 usage unique/tige en matière plastique
 uzar una vez/material del mango de plástico

für die Entfernung
 von Kunststoffresten
 nach der Bracketent-
 fernung geeignet

Korngröße grob
 Bindungshärte hart

for removal of
 adhesive residues
 after debonding

grit size coarse
 bond hardness medium

l'enlèvement des restes
 d'adhésif après le
 traitement de brackets

taille de grain gros
 dureté de liaison moyen

para la eliminación
 de retales de adhesivos
 después de quitar brackets

tamaño de grano grueso
 dureza de la ligazón media



W/RA/CA ISO 633 204 ...	9650/030 297 544 030	9650/050 243 544 050
L mm	7,5	10,0

Spezialpolierer, verletzt nicht die natürliche Zahnschicht
 special polishers do not harm the enamel
 polisseuse spéciale, blessée pas le naturel substance dentaire
 pulidora especial, lesionada no el natural sustancia dental

für die Anwendung
mit Polierpaste

Polyamidbürsten
(ohne Schleifkorn)

for the application with
polishing paste

polyamide brushes
(without abrasive grit)

pour l'application avec
pâte à polir

brosse polyamide
(sans grain abrasif)

para aplicación con
pasta de pulir

cepillos de poliamid
(sin grano abrasivo)

hart/hard/dur/duro



W/RA/CA ISO 010 204 ...	9635H/060 010 700 060	9730H/040 010 700 040	9731H/040 131 700 040
L mm	5,5	6,0	6,5

für hartnäckige Verfärbungen
for resistant tooth stains
pour les taches dentaires résistantes
para manchas dentales resistentes

Einmalinstrumente
single use instruments
usage unique
usar una vez

weich/soft/doux/blando



W/RA/CA ISO 010 204 ...	9635/060 010 500 060	9730/040 010 500 040	9731/040 131 500 040
L mm	5,5	6,0	6,5

Einmalinstrumente
single use instruments
usage unique
usar una vez

super weich/super soft/super doux/super blando



W/RA/CA ISO 010 204 ...	9635S/060 010 300 060	9730S/040 010 300 040	9731S/040 131 300 040
L mm	5,5	6,0	6,5

für schonende Prophylaxe
z.B. Parodontal-Patienten, Kindern etc.
for gentle prophylaxis, e.g. periodontitis patients,
children, etc.
pour une prophylaxie douce, par exemple chez les
patients atteints de parodontite, les enfants, etc.
para una profilaxis suave, por ejemplo, en pacientes
con periodontitis, niños, etc.

Einmalinstrumente
single use instruments
usage unique
usar una vez

Zahnmedizin

Dentistry • Odontologie • Odontologia



Schleifkörper

Abrasives • Abrasifs • Abrasivos

Schleifkörper für Keramik, Kunststoffe, Metall-Legierungen, Schmelz
Abrasive for ceramic, acrylics, metal alloys, enamel
Abrasifs pour céramique, acrylique, alliages métalliques, émail
Abrasivos para cerámica, acrílico, aleaciones, metálicas, esmalte 76

Schleifkörper für Komposite
Abrasive for composites
Abrasifs pour composites
Abrasivos para composite 77



Schleifkörper

Abrasives

Abrasifs

Abrasivos

für Keramik, Kunststoffe,
Metall-Legierungen,
Schmelz , grün

Siliziumkarbid
Schleifkörper (SiC), grün
Keramische Bindung
Korngröße mittel
Bindungshärte mittel

for ceramic, acrylics,
metal alloys, enamel,
green

silicon carbide
abrasives (SiC), green
ceramic bond
grit size medium
bonding hardness medium

pour céramique,
acrylique, alliages
métalliques, émail, vert

abrasifs en carbure de
silicium (SiC), vert
liaison céramique
taille de grain moyen
dureté de liaison moyen

para cerámica, acrílico,
aleaciones metálicas,
esmalte, verdes

abrasivos de carburo
de silicio (SiC), verde
ligazón cerámica
tamaño de grano medio
dureza de la ligazón media



W/RA/CA ISO 655 204 ...	601/030 001 523 030	602/040 001 523 040	603/050 001 523 050	619/050 042 523 050	622/060 042 523 060	626/050 068 523 050	627/060 068 523 060	637/025 110 523 025
L mm	-	-	-	2,90	3,40	2,90	2,90	6,00



W/RA/CA ISO 655 204 ...	648/020 171 523 020	649/025 171 523 025	661/030 243 523 030	662/035 243 523 035	666/033 257 523 033	667/040 257 523 040	671/050 260 523 050
L mm	6,0	6,0	6,5	7,5	6,0	7,0	10,0

für Feinstbearbeitung
 von Kompositen, weiß

Edelkorund Arkansas
 Schleifkörper (Al₂O₃),
 weiß
 Keramische Bindung
 Korngröße extra fein
 Bindungshärte hart

for smooth grinding
 of composites, white

high-grade corundum
 arkansas abrasives (Al₂O₃),
 white
 ceramic bond
 grit size extra fine
 bonding hardness hard

pour le finissage
 de composites, blanc

abrasifs arkansas
 en corindon affiné (Al₂O₃),
 blanc
 liaison céramique
 taille de grain extra fin
 dureté de liaison dure

para correcciones finas
 de composite, blancos

abrasivos arkansas
 de corindón fino (Al₂O₃),
 blanco
 ligazón cerámica
 tamaño de grano extra fino
 dureza de la ligazón dura

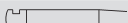

 FG ISO 635 314 ...	601/030 001 504 030	649/025 171 504 030	653/030 204 504 030	661/030 243 504 030	638/030 110 504 030
 W/RA/CA ISO 635 204 ...	601/030 001 504 030	649/025 171 504 030	653/030 204 504 030	661/030 243 504 030	
L mm	-	6,0	10,5	6,5	6,0

Zahntechnik

Dental Technology • Prothese Dentaire • Protesis Dental



Diamant

Diamond • Diamant • Diamante

Anwendungsbeispiele
Examples of application
Exemples d'application
Ejemplos de aplicaciones 80+81











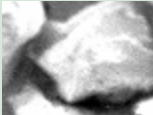

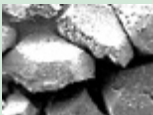
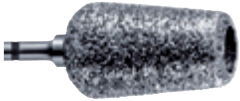

DiaTWISTER 82

Premium Diamantschleifer
Premium diamond instruments
Instruments diamantés supérieurs
Instrumentos diamantados superiores 83-89



ZIRAMANT 90+91

Diamantscheiben, montiert
Diamond discs, mounted
Disques diamantés, montés
Discos diamantados, montados 92+93

Longlife Sinter-Diamantschleifer
Longlife sintered diamond instruments
Diamant dans la masse Longlife
Instrumentos diamantados sinterizados Longlife 94+95

Einsatzgebiet	Arbeitsgang	Körnung	Instrumentenbeispiel	ISO-Ø	empf. Drehzahl min ⁻¹
application area	working process	R.E.M. (30x)	examples of instr.		recommended speed
domaine d'application	phase de travail	grit D.S.M. (30x)	exempl. d'instruments		vit. de rotation rec.
uso en sector	fase de trabajo	grain M.E.B. (30x)	ej. de los instrumentos		veloc. recomendada
		M.E.B. (30x)			
		grano M.E.R. (30x)			
KFO-Prothesen-kunststoff KFO for denture acrylic résine pour prothèse amovible acrilica para ortodoncía y dentadura	zügiges Vorschleifen faster pregrinding dégrossissage rapide rectificado inicial rápido		DT4880/100 	070 – 120	22.000 – 15.000
Kunststoff, Gips acrylic, plaster résine, plâtre acrilica, yeso	Vorschleifen pregrinding dégrossissage rectificado inicial		5405/115 	050 – 075 085 – 115	32.000 – 15.000 18.000 – 15.000
Keramik, Komposit ceramic, composite céramique, composite cerámica, composite	Vorschleifen pregrinding dégrossissage tallado inicial		6863/019 	018 – 063	35.000 – 15.000
	Formschleifen shape grinding façonnage rectificado de forma		859/018 	009 – 085	
	Feinschleifen fine grinding abrasion de précision rectificado fino		8850/023 	012 – 060	
Keramik ceramic céramique cerámica	Oberflächen-Feinstbearbeitung finest surface treatments superfinition de surfaces preparaciones muy finas de superficies		390EF/018 	012 – 047	35.000 – 15.000
Zirkonoxid Zirconia oxyde de zirconium óxido de zirconio	Beschleifen/Feinschleifen grinding/fine grinding meulage/abrasion de précision afilarse/rectificado fino		6860Z/014  8860Z 	009 – 025	200.000 – 180.000*

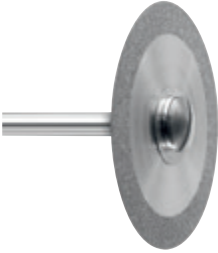
* Turbine mit Kühlung/turbine with cooling/turbine avec refroidissement/turbina con refrigeración

Einsatzgebiet	Arbeitsgang	Körnung	Instrumentenbeispiel	ISO-Ø	empf. Drehzahl min ⁻¹
application area	working process	grit	examples of instr.		recommended speed
domaine d'application	phase de travail	grain	exempl. d'instruments		vit. de rotation rec.
uso en sector	fase de trabajo	grano	ej. de los instrumentos		veloc. recomendada
Gips, Komposit, Keramik plaster, composite, ceramic plâtre, composite, céramique yeso, composite, ceramica	Modellherstellung, Separieren von Brückengliedern model fabrication separating of bridge links fabrication de modèles séparation des éléments de bridge fabricación de modelos separación de elementos de puente	Diamant-Scheiben, montiert mittel & fein diamond discs mounted medium + fine disques diamantés, monté moyen + fin discos diamantados, montados medio + fino	911H/220 	080 – 300	35.000 – 9.000
CrCo-Legierungen CrCo-alloys alliages CrCo aleaciones cromocobaltos	Formschleifen shape grinding façonnage rectificado de forma	Longlife Sinter-Diamant, grob Longlife Sintered diamond instruments, coarse diamant dans la masse Longlife, gros instrumentos diamantados sinterizados Longlife, grueso	1893/050 	031 – 210	28.000 – 8.000
	feinschleifen fine grinding abrasion de précision rectificado fino	Longlife Sinter-Diamant, mittel Longlife Sintered diamond instruments, medium diamant dans la masse Longlife, moyen instrumentos diamantados sinterizados Longlife, medio	3368/016 	016 – 080	32.000 – 10.000

DiaTWISTER

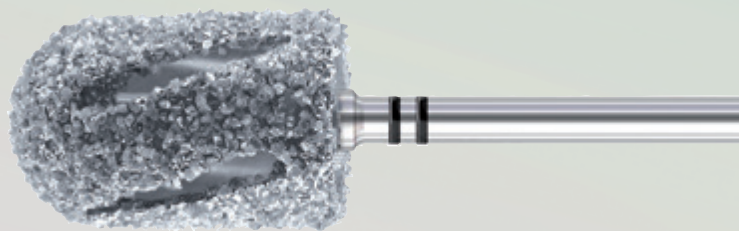

- für das kühle Vorschleifen von Kfo- und Prothesenkunststoff
- für das Bearbeiten von individuellen Abdrucklöffeln und Gips
- for cool pregrinding of orthodontic and denture acrylics
- for the processing of individual impression trays and plaster
- pour le dégrossissage des résines orthodontiques et prothétiques sans échauffement
- pour le traitement de PEI et plâtre synthétique
- para el rectificado frío inicial de resina para ortodoncia y protética
- para la elaboración de cubetas de impresión individuales y yeso

Mega grobe Körnung
mega coarse grit
grain mega gros
grano hiper grueso

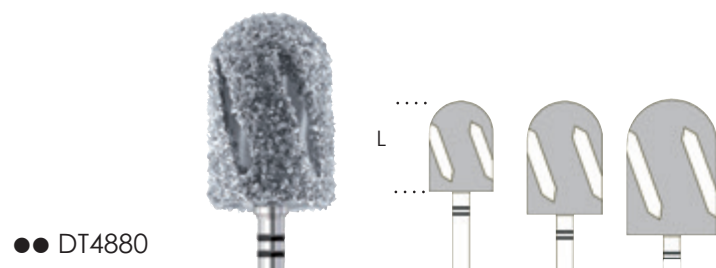

●● DT4880



●● H/HP/PM DiaTWISTER	DT4880/...	085	100	120
L mm		12,5	15,0	18,0



●● DT4854R



●● H/HP/PM DiaTWISTER	DT4854R/...	100	120
L mm		16,0	19,0

Super grobe Körnung
super coarse grit
grain super gros
grano super grueso

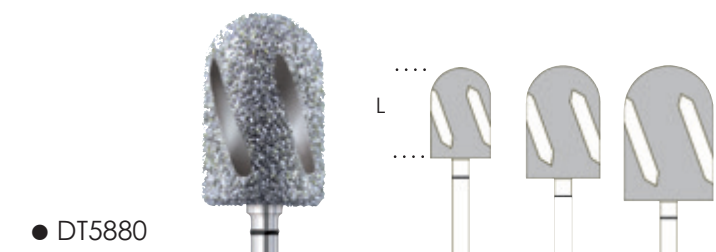

● DT5880



● H/HP/PM DiaTWISTER	DT5880/...	080	095	115
L mm		12,0	15,0	18,0



● DT5854R



● H/HP/PM DiaTWISTER	DT5854R/...	095	115
L mm		15,5	18,5

801

H/HP/PM ISO 806 104 001 524...	801/...	009	010	012	014	016	018	021	023	029	035	042	050
-----------------------------------	---------	-----	-----	-----	-----	-----	-----	-----	-----	-----	-----	-----	-----

805

L : : : :

H/HP/PM ISO 806 104 010 524...	805/...	012	014	016	018	021	023
L mm		1,5	1,6	1,7	1,8	2,1	2,3

807

L : : : :

H/HP/PM ISO 806 104 225 524...	807/...	016	023
L mm		4,0	6,0

835

L : : : :

H/HP/PM ISO 806 104 107 524...	835/...	010	012	014	016	018	021
L mm		4,0	4,0	4,0	4,0	5,0	5,0

836

L : : : :

H/HP/PM ISO 806 104 110 524...	836/...	012	014	027
L mm		6,0	6,0	6,0

ISO-Ø 009-035 = ISO-Ø 042+050 =

mittlere Körnung, medium grit, grain moyen, grano mediano

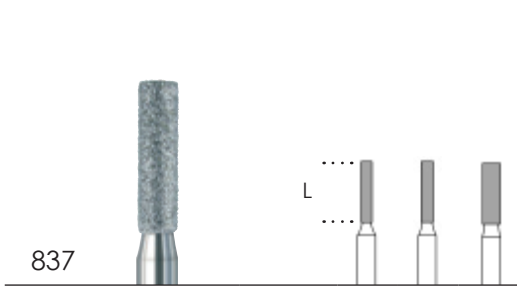

				
H/HP/PM	837/...	014	016	023
ISO 806 104 111 524...				
L mm		8,0	8,0	8,0



			
H/HP/PM	842/...	021	
ISO 806 104 113 524...			
L mm		12,0	



				
H/HP/PM	880/...	014	018	027
ISO 806 104 140 524...				
L mm		6,0	6,0	6,0



			
H/HP/PM	842R/...	021	
ISO 806 104 143 524...			
L mm		12,0	



				
H/HP/PM	845/...	010	012	016
ISO 806 104 168 524...				
L mm		4,0	4,0	4,0



			
H/HP/PM	846/...	025	
ISO 806 104 171 524...			
L mm		7,0	

mittlere Körnung, medium grit, grain moyen, grano mediano

847

H/HP/PM ISO 806 104 172 524...	847/...	014	018	023
L mm		8,0	8,0	8,0

848

H/HP/PM ISO 806 104 173 524...	848/...	016	018
L mm		10,0	10,0

● 6854
 854
 ● 8854

● H/HP/PM ISO 806 104 172 534...	6854/...			050
H/HP/PM ISO 806 104 172 524...	854/...	033	040	
● H/HP/PM ISO 806 104 172 514...	8854/...	033	040	
L mm		9,0	9,0	10,0

● 6854R
 854R
 ● 8854R

● H/HP/PM ISO 806 104 198 534...	6854R/...		035	
H/HP/PM ISO 806 104 198 524...	854R/...	033		040
● H/HP/PM ISO 806 104 198 514...	8854R/...	033		040
L mm		9,0	9,1	9,0

ISO-Ø 014-023 = ISO-Ø 033-050 =

- grobe Körnung, coarse grit, gros grain, grano grueso
 mittlere Körnung, medium grit, grain moyen, grano mediano
- feine Körnung, fine grit, grain fin, grano fino

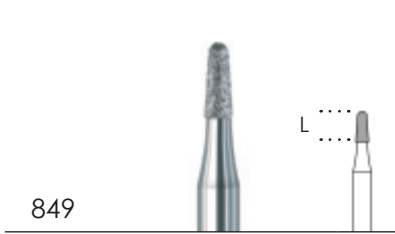

849

			
H/HP/PM	849/...	016	
ISO 806 104 194 524...			
L mm		4,0	



855

			
H/HP/PM	855/...	025	
ISO 806 104 197 524...			
L mm		7,0	



856

			
H/HP/PM	856/...	014	
ISO 806 104 198 524...			
L mm		8,0	

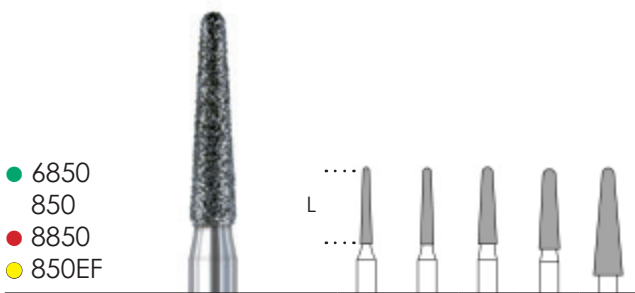

850 series

						
● H/HP/PM	6850/...				025	
ISO 806 104 199 534...						
H/HP/PM	850/...	014	016	023		
ISO 806 104 199 524...						
H/HP/PM	850/...				037	
ISO 806 104 201 524...						
● H/HP/PM	8850/...	014	016	023		
ISO 806 104 199 514...						
● H/HP/PM	850EF/...		016			
ISO 806 104 199 504...						
L mm		10,0	10,0	10,0	10,4	14,0



858 series

			
H/HP/PM	858/...	014	
ISO 806 104 165 524...			
● H/HP/PM	8858/...	014	
ISO 806 104 165 514...			
● H/HP/PM	858EF/...	014	
ISO 806 104 165 504...			
L mm		8,0	



852 series

					
H/HP/PM	852/...	023	031	037	050
ISO 806 104 159 524...					
L mm		6,0	7,0	7,0	7,0

ISO-Ø 014-031 =  ISO-Ø 037-050 = 

● grobe Körnung, coarse grit, gros grain, grano grueso
 mittlere Körnung, medium grit, grain moyen, grano mediano
 ● feine Körnung, fine grit, grain fin, grano fino
 ● extra feine Körnung, extra fine grit, grain extra fin, grano extra fino

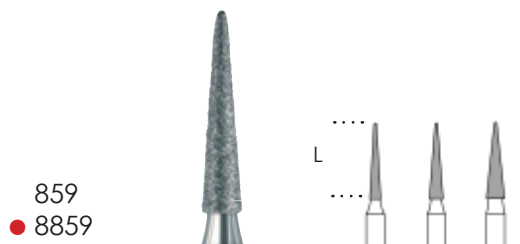

859
 ● 8859



H/HP/PM ISO 806 104 166 524...	859/...	014	018	023
● H/HP/PM ISO 806 104 166 514...	8859/...		018	
L mm		10,0	10,0	10,0



860
 ● 8860



H/HP/PM ISO 806 104 245 524...	860/...	012	016
● H/HP/PM ISO 806 104 245 514...	8860/...	012	
L mm		5,0	5,0



● 6862
 862



● H/HP/PM ISO 806 104 249 534...	6862/...		018	
H/HP/PM ISO 806 104 249 524...	862/...	014	018	023
L mm		8,0	8,0	8,0



● 6863
 863
 ● 8863
 ● 863EF



● H/HP/PM ISO 806 104 250 534...	6863/...			019		
H/HP/PM ISO 806 104 250 524...	863/...	012	016		025	031
● H/HP/PM ISO 806 104 250 514...	8863/...	012	016			
● H/HP/PM ISO 806 104 250 504...	863EF/...	012				
L mm		10,0	10,0	10,0	10,0	10,0



390
 ● 8390
 ● 390EF



H/HP/PM ISO 806 104 274 524...	390/...	018
● H/HP/PM ISO 806 104 274 514...	8390/...	018
● H/HP/PM ISO 806 104 274 504...	390EF/...	018
L mm		3,7



368
 ● 8368



H/HP/PM ISO 806 104 257 524...	368/...	023
● H/HP/PM ISO 806 104 257 514...	8368/...	023
L mm		5,0



379



H/HP/PM ISO 806 104 277 524...	379/...	014	023
L mm		2,8	4,2

909



L : : : : :



H/HP/PM	909/...	040	055
ISO 806 104 068 524...			
L mm		1,0	2,0

818



L : : : : :



H/HP/PM	818/...	023	035	050	070
ISO 806 104 041 524...					
L mm		0,6	0,6	0,6	0,6

812



L : : : : :



H/HP/PM	812/...	055
ISO 806 104 022 524...		
L mm		2,8

825



L : : : : :



H/HP/PM	825/...	050	060
ISO 806 104 304 524...			
L mm		1,1	1,3

830



L : : : : :
 : : : : :
 : : : : :



H/HP/PM	830/...	070
ISO 806 104 237 524...		
L mm		12,0

● 5369
 369

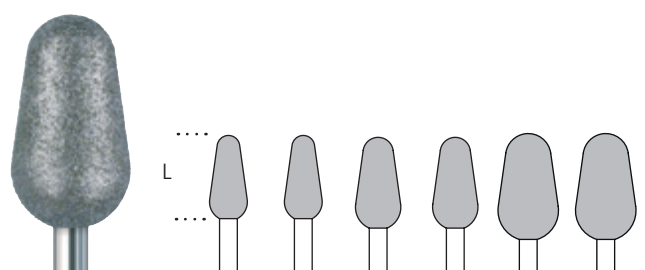

L : : : : :
 : : : : :
 : : : : :



● H/HP/PM	5369/...		055		065		085
ISO 806 104 263 544...							
H/HP/PM	369/...	050		060		080	
ISO 806 104 263 524...							
L mm		11,0	11,5	12,0	12,5	14,0	14,3

● sehr grobe Körnung, very coarse grit, très gros grain, grano muy grueso
 mittlere Körnung, medium grit, grain moyen, grano mediano

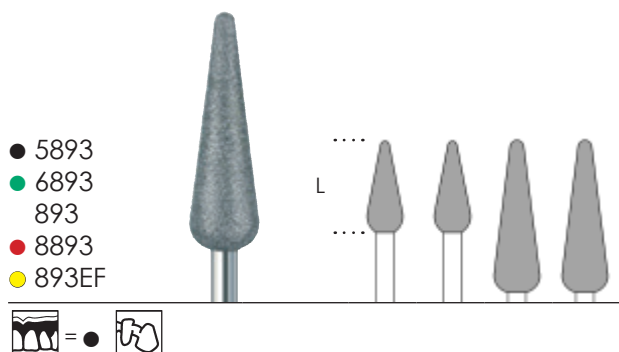

- 5893
- 6893
- 893
- 8893
- 893EF

● H/HP/PM ISO 806 104 266 544...	5893/...		050		065
● H/HP/PM ISO 806 104 266 534...	6893/...		050		
H/HP/PM ISO 806 104 266 524...	893/...	047		060	
● H/HP/PM ISO 806 104 266 514...	8893/...	047			
● H/HP/PM ISO 806 104 266 504...	893EF/...	047			
L mm		12,0	12,3	20,0	20,3

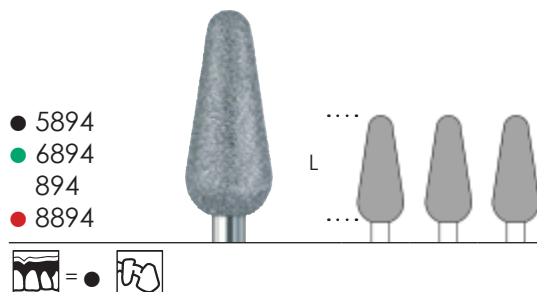

- 5894
- 6894
- 894
- 8894

● H/HP/PM ISO 806 104 263 544...	5894/...			065
● H/HP/PM ISO 806 104 263 534...	6894/...		063	
H/HP/PM ISO 806 104 263 524...	894/...	060		
● H/HP/PM ISO 806 104 263 514...	8894/...	060		
L mm		14,0	14,3	14,3

Hohlschleifer
 hollow instruments
 instruments creux
 instrumentos huecos

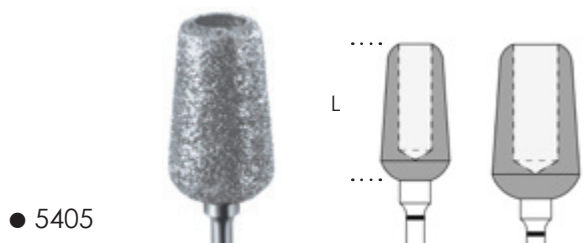

- 5405

● H/HP/PM	5405/...	090	115
L mm		18,0	20,3

ISO-Ø 047-115 =

- sehr grobe Körnung, very coarse grit, très gros grain, grano muy grueso
- grobe Körnung, coarse grit, gros grain, grano grueso
- mittlere Körnung, medium grit, grain moyen, grano mediano
- feine Körnung, fine grit, grain fin, grano fino
- extra feine Körnung, extra fine grit, grain extra fin, grano extra fino

ZIRAMANT

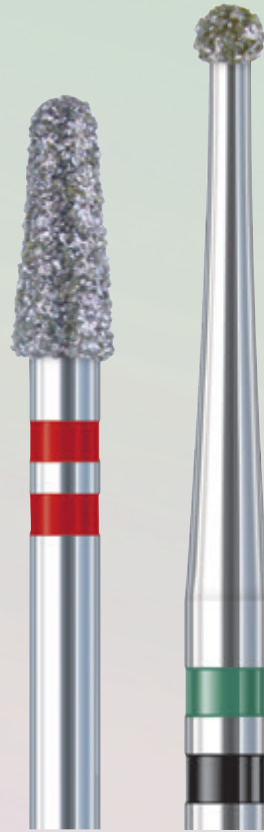

- für das Bearbeiten von Zirkonoxid mit der Labor-Turbine und Wasserkühlung
- for working on zirconia with laboratory turbines and coolant
- pour le traitement de l'oxyde de zirconium avec turbine laboratoire et refroidissement à l'eau
- para el tratamiento de óxido de circonio con la turbina y refrigeración del spray

Punktförmiges und flächiges Ausschleifen
 grinding individual points and larger areas
 abrasion ponctuelle et de surfaces
 fresado en punta y liso



●● 6801LZ



●● FG x-lg	6801LZ/...	014
ISO 806 316 001 535...		













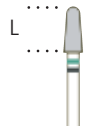

●● 6838LZ

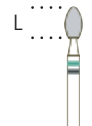





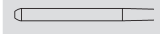
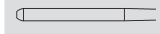

●● FG x-lg	6838LZ/...	012
ISO 806 316 137 525...		
L mm		2,5



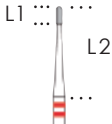

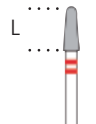

●● grobe Körnung, coarse grit, gros grain, grano grueso

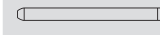
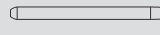
Formschleifen an flächigen, konkaven und schwer zugänglichen Bereichen
 shape grinding on larger, concaved and inaccessible areas
 façonnage de zones planes, concaves et à accès difficile
 rectificado en superficies lisas, concavas y de difícil acceso

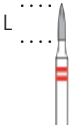
 	 	 
●● 6855Z	●● 6860Z	●● 6379Z
 	 	 
		
●● FG Ig	●● FG Ig	●● FG Ig
6855Z/... 025	6860Z/... 014	6379Z/... 023
ISO 806 315 197 535...	ISO 806 315 245 535...	ISO 806 315 277 535...
L mm	L mm	L mm
6,0	5,0	4,2

Feinbearbeitung mit geringer Rautiefe an kritischen Stellen und bruchgefährdeten Randbereichen
 smooth fine finishing with little roughness on critical areas and fragile edge areas
 finition à faible profondeur de rugosité à des endroits critiques et dans des zones de bordure fragiles
 trabajos precisos de menor profundidad de rugosidad en zonas críticas y zonas aledañas con riesgo de ruptura

 	 
●● 8838LZ	●● 8855Z
 	 
	
●● FG x-Ig	●● FG Ig
8838LZ/... 009	8855Z/... 021
ISO 806 316 137 515...	ISO 806 315 197 515...
L1 mm	L mm
2,30	6,0
L2 mm	
11,8	

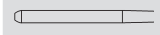
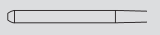
 	 
●● 8860Z	●● 8379Z
 	 
	
●● FG Ig	●● FG Ig
8860Z/... 010	8379Z/... 019
ISO 806 315 245 515...	ISO 806 315 277 515...
L mm	L mm
5,0	4,2

●● grobe Körnung, coarse grit, gros grain, grano grueso
 ●● feine Körnung, fine grit, grain fin, grano fino

Rand diamantdurchsetzt
 rim diamond interspersed
 bord imprégné de diamant
 borde impregnado de diamante

Kera-Flex

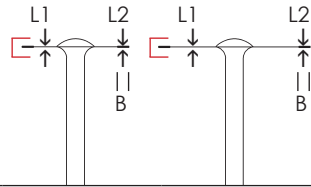

7911



H/HP/PM ISO 806 104 354 514...	7911/...	140	200
L1		0,15	0,15
L2		0,17	0,17
B		1,5	2,0

Kera-Super-Flex

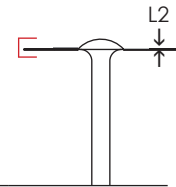
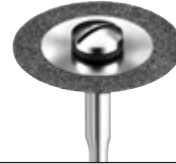

7912



H/HP/PM ISO 806 104 358 514...	7912/...	200
L2		0,17

Rand galvanisch diamantbelegt
 rim galvanic diamond coated
 bord recouvert de diamant par galvanisation
 borde recubierto de diamante galvanizado

Super-Flex

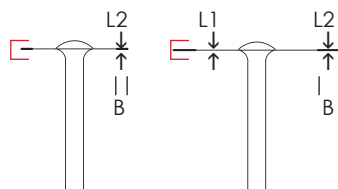

911H



H/HP/PM ISO 806 104 355 514...	911H/...	140	220
L1		0,06	0,06
L2		0,2	0,2
B		2,0	3,0

Super-Flex

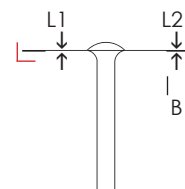

911HH



H/HP/PM ISO 806 104 356 514...	911HH/...	220
L1		0,06
L2		0,1
B		3,0

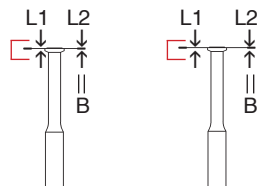

Super-Flex



943



H/HP/PM ISO 806 104 361 514...	943/...	080	100
L1		0,06	0,06
L2		0,15	0,15
B		1,0	1,0

-  = oben und unten diamantiert/top and bottom diamond-coated/
dessus et dessous diamantés/parte superior e inferior recubiertas de diamante
-  = unten diamantiert/ bottom diamond-coated/
dessous diamantés/ parte inferior recubiertas de diamante
-  = oben diamantiert/top diamond-coated/
dessus diamantés/ parte superior recubiertas de diamante

Diamantscheiben, montiert
 Diamond discs, mounted
 Disques diamantés, montés
 Discos diamantados, montados

Zahntechnik
 Dental Technology
 Prothese Dentaire
 Protesis Dental

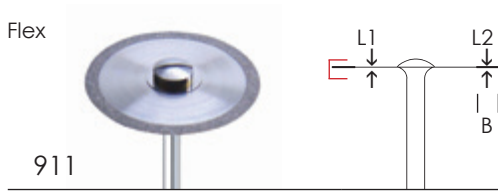

H/HP/PM ISO 806 104 340 514...	911/...	220
L1		0,1
L2		0,25
B		2,0



H/HP/PM ISO 806 104 350 524...	918PB/...	220
L1		0,1
L2		0,3
B		7,5



H/HP/PM ISO 806 104 351 524...	919P/...	220
L1		0,1
L2		0,2
B		7,5

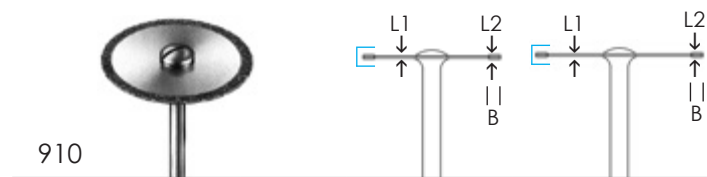

H/HP/PM ISO 806 104 321 524...	910/...	180	220
L1		0,25	0,25
L2		0,55	0,55
B		2,0	2,0



H/HP/PM ISO 806 104 329 524...	916/...	220
L1		0,3
L2		0,45
B		7,5



H/HP/PM ISO 806 104 076 524...	902/...	150
L2		3,3

Modellherstellung/model fabrication/fabrication de modèles/fabricación de modelos

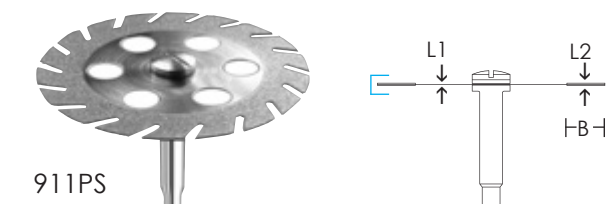

H/HP/PM ISO 806 104 333 524...	911PS/...	300
L1		0,21
L2		0,3
B		5,0



H/HP/PM ISO 806 104 365 514...	911S/...	220
L1		0,1
L2		0,27
B		3,4

● mittlere Körnung, medium grit, grain moyen, grano mediano
 ● feine Körnung, fine grit, grain fin, grano fino



3859



H/HP/PM	3859/...	031	
ISO 807 104 166 524...			
H/HP/PM	3859/...		050
ISO 807 104 161 524...			
L mm		8,5	11,0



3368



H/HP/PM	3368/...	016	
ISO 807 104 257 524...			
L mm			6,5

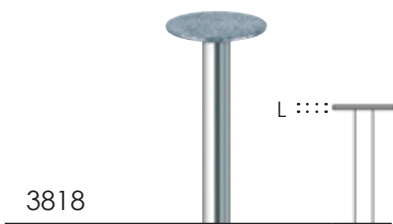

3818



H/HP/PM	3818/...	080	
ISO 807 104 041 524...			
L mm			0,5



● 1351
3351



● H/HP/PM	1351/...	050	
ISO 807 104 263 534...			
H/HP/PM	3351/...	050	
ISO 807 104 263 524...			
L mm			12,0



● 1850
3850



● H/HP/PM	1850/...	031	
ISO 807 104 200 534...			
H/HP/PM	3850/...	031	
ISO 807 104 200 524...			
L mm			12,0

● grobe Körnung, coarse grit, gros grain, grano grueso
 mittlere Körnung, medium grit, grain moyen, grano mediano



● 1837



● H/HP/PM ISO 807 104 111 534...	1837/...	031
● H/HP/PM ISO 807 104 112 534...	1837/...	
L mm		8,5



● 1881



● H/HP/PM ISO 807 104 143 534...	1881/...	050
L mm		12,0



● 1893



● H/HP/PM ISO 807 104 201 534...	1893/...	050
L mm		16,0



● 1941



● H/HP/PM ISO 807 104 327 534...	1941/...	210
L mm		0,45

● grobe Körnung, coarse grit, gros grain, grano grueso

Zahntechnik



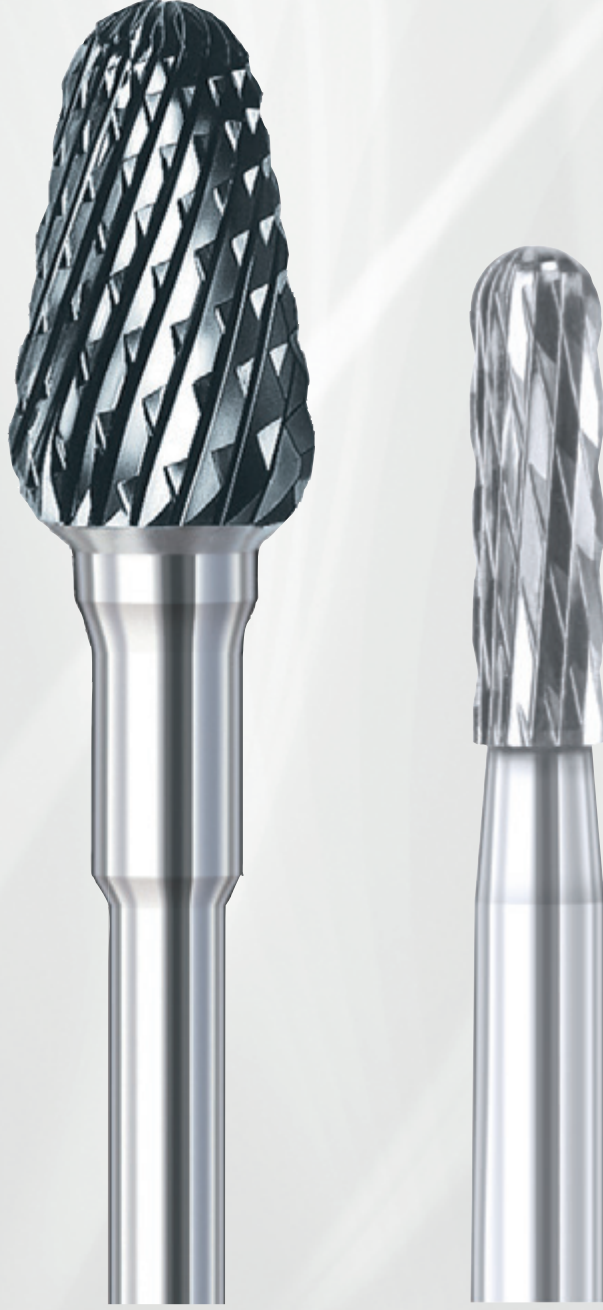











Dental Technology • Prothese Dentaire • Protesis Dental

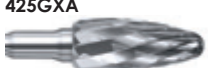

Hartmetall

Carbide • Carbure • Carburo

Anwendungsbeispiele Examples of application Exemples d'application Ejemplos de aplicaciones	98-100
Bohrer, Finierer Burs, Finishing burs Fraises, Fraises à finir Fresas, Fresas para acabar	101-104
Laborfräser, groß, Linkshänder-Fräser Carbide cutters, large, Left-handed cutters Fraises en Carbure, grandes, Fraise pour gaucher Fresas de Carburo, grandes, Fresa para zurdos	105-112
Laborfräser, klein/MIDIS/SHORTIES Carbide cutters, small /MIDIS/SHORTIES Fraises en Carbure, petites /MIDIS/SHORTIES Fresas de Carburo, pequeñas /MIDIS/SHORTIES	113-118
Werkzeuge für die Frästechnik Instruments for milling technique Instruments pour technique de fraisage Instrumentos para la técnica de fresado	119-123

Einsatzgebiet used on domaine d'application uso en sector	Arbeitsgang working process phase de travail fase de trabajo	Verzahnungsart type of cuts type de denture tipos de dentado	Instrumentenbeispiel examples of instr. exempl. d'instruments ej. de los instrumentos	ISO-Ø	empf. Drehzahl min ⁻¹ recom. speed r.p.m. vit. de rotation rec. veloc. recomendada
Nasser Gips wet plaster plâtre humide yeso humedo	Grobes Abtragen coarse removal abrasion forte abrasión gruesa	SGX Sehr grobe X-Verzahnung very coarse double cut denture croisée très grosse dentado muy grueso cruz.	425SGX 	045-080	20.000 - 10.000
		SG Sehr grobe Verzahnung very coarse cut denture très grosse dentado muy grueso	425SG 	060	15.000 - 10.000
Trockener Gips, Kunststoff dry plaster, acrylic plâtre sec, résine yeso seco, resina	Grobes Abtragen coarse removal abrasion forte abrasión gruesa	GX Grobe X-Verzahnung coarse double cut denture croisée grosse dentado grueso cruzado	429GX 	045-080	20.000 - 10.000
		G Grobe Verzahnung coarse cut denture grosse dentado grueso	425G 	045-080	20.000 - 10.000
Nasser Gips wet plaster plâtre humide yeso humedo	Grobes, sicheres Abtragen coarse, safe removal abrasion, forte et sûr abrasión, gruesa segura	SGXA Sehr grobe X-Verzahnung linksgedrallt very coarse double cut left twisted dent. croisée très grosse avec torsion à gauche dentado muy grueso cruz., con torsión izquierda	425SGXA 	060-070	15.000 - 10.000
		GXA Grobe X-Verzahnung, linksgedrallt coarse double cut, left twisted denture croisée grosse avec torsion à gauche dentado muy grueso cruz. con torsión izquierda	425GXA 	060	15.000 - 10.000
Weichbleibende Kunst- stoffe (Unterfütterungen) non-hardening acrylics (relinings) résine molle (rebasage) material de rebases blandos y cubeta	Ausarbeiten work out ajustage reparado	GQSR Grobe gerade schnittfr. Verzahnung mit Querhieb coarse straight power cut/ with cross-cut denture droite grosse sécante avec taille transversale dentado grueso recto con corte transversal	424GQSR 	040-060	18.000 - 10.000
			M433GQSR 	016-023	25.000 - 15.000
Weiche Kunststoffe (Schienen) soft acrylics (splints) résine molle (gouttière) resinas blandos (rieles)	Ausarbeiten work out ajustage reparado	MQS Mittlere Verzahnung mit Querhieb medium cut with cross cut denture moyenne avec taille transversale dentado medio con corte transversal	425MQS 	023-060	25.000 - 10.000
			M426MQS 	016-023	25.000 - 15.000
Synth. Gips, Kunststoffe synthetic plaster, acrylic plâtre synthétique, résine yeso sintético, resina	Formfräsen shape milling façonnage par fraisage fresar para formar	Mittlere Verzahnung medium cut denture moyenne dentado medio	425 	023-080	25.000 - 10.000
Titan titanium titane titanio	Ausarbeiten, Formfräsen work out, shape milling ajustage, façonnage par frais. fresar y formar	Mittlere X-Verzahnung medium double cut denture croisée moyenne dentado medio cruzado	429XTi 	040	22.500 - 15.000
			S423XTi 	012-023	25.000 - 15.000
			M426XTi 	016-023	25.000 - 15.000













Hartmetall • Anwendung Fräser, Bohrer, SHORTIES + MIDIS

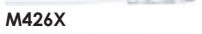

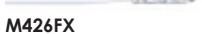





Carbide • Application Cutters, Burs, SHORTIES + MIDIS

Carbure • Application Fraises, SHORTIES + MIDIS

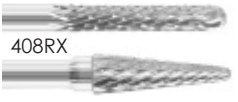
Carburo • Empleo Fresas, SHORTIES + MIDIS

Zahntechnik
Dental Technology
Prothèse Dentaire
Protesis Dental

Einsatzgebiet used on domaine d'application uso en sector	Arbeitsgang working process phase de travail fase de trabajo	Verzahnungsart type of cuts type de denture tipos de dentado	Instrumentenbeispiel examples of instr. exempl. d'instruments ej. de los instrumentos	ISO-Ø	empf. Drehzahl min ⁻¹ recom. speed r.p.m. vit. de rotation rec. veloc. recomendada
Keramik, Komposit ceramic, composite céramique, composite cerámica, composite	Ausarbeiten, Formfräsen work out, shape milling ajustage, façonnage par frais. fresar y formar	FXK Feine X-Verzahnung fine double cut denture croisée fine dentado fino cruzado	432FXK 	023	25.000 - 15.000
			S426FXK 	012-023	25.000 - 15.000
			M426FXK 	016-023	25.000 - 15.000
Synth. Gips, Prothesen-/ Löffel-Kunststoff Au-, Ag-, Pd-, CrCo- + NiCr-Leg. synthetic plaster, denture resin, individual trays Au- Ag-, Pd-, CrCo- + NiCr-All. plâtre synthétique, résine p. prothèse amovible alliages Au, Ag, Pd, CrCo + NiCr yeso sint., Resina para remoribl.y ortod. cubetas acr. Au-, Ag-, Pd-, CrCo- + NiCr-Al.	Ausarbeiten, Formfräsen work out, shape milling ajustage, façonnage par frais. fresar y formar	X (L) Mittlere X-Verzahnung medium double cut denture croisée moyenne dentado medio cruzado	425X 	023-080	25.000 - 15.000
			S426X 	014-023	25.000 - 15.000
			M426X 	016-023	25.000 - 15.000
Keramik, Titan, Komposit Au-, Ag-, Pt-Legierungen ceramic, titanium, compos. Au-, Ag-, Pt-Alloys céramique, titane, compos. alliages Au, Ag + Pt cerámica, titanio, compos. Au-, Ag-, Pt-Aleaciones	Feinstbearbeitung, Oberflächenrelief finest finishing, surface reliefs superfinition, relief de surface trabajos precisos en super- ficie	FX (L) Feine X-Verzahnung fine double cut denture croisée fine dentado fino cruzado	425FX 	023-060	25.000 - 15.000
			S426FX 	012-023	25.000 - 15.000
			M426FX 	016-023	25.000 - 15.000
Keramik, Titan, Komposit Au-, Ag-, Pt-Legierungen ceramic, titanium, compos. Au-, Ag-, Pt-Alloys céramique, titane, compos. alliages Au, Ag + Pt cerámica, titanio, compos. Au-, Ag-, Pt-Aleaciones	Feinstbearbeitung, Oberflächenrelief finest finishing, surface reliefs superfinition, relief de surface trabajos precisos en super- ficie	FFX Sehr feine X-Verzahnung super fine double cut denture croisée très fine dentado superfino cruzado	425FFX 	023-060	20.000 - 10.000
			S426FFX 	014-023	20.000 - 10.000
			M426FFX 	016-023	20.000 - 10.000
Metalllegierungen, Kunststoffe, Composite, Gipse metal alloys, acrylic, composite, plaster alliages métalliques, résines, composites, plâtres aleaciones metalicas, resina, composite, yeso	Formgebung, Oberflächenbearbeitung, Fissurenbearbeitung shaping, surface finishings, fissure finishings façonnage, traitement des surfaces, traitement de fissures moldeado, tratamiento de superficies y tratamiento de fisuras	Mittlere Verzahnung medium cut denture moyenne dentado medio	1 	003-027	25.000 - 15.000
		Mittlere Verzahnung mit Querhieb medium cut with cross cut denture moyenne avec taille transversale dentado medio con corte transversal	31R 	008-023	25.000 - 15.000
Metalle metals métaux metales	Finieren finishing finissage acabado	Standard-Finierer-Verzahnung standard finishing cut denture de fraise à finir stand. dentado para acabar estándar	41 	012-023	25.000 - 15.000

Einsatzgebiet used on domaine d'application uso en sector	Arbeitsgang working process phase de travail fase de trabajo	Verzahnungsart type of cuts type de denture tipos de dentado	Instrumentenbeispiel examples of instruments exempl. d'instruments ej. de los instrumentos	empf. Drehzahl min ⁻¹ recom. speed r.p.m. vit. de rotation rec. veloc. recomendada
Wachs wax cire cera	Schaben scaling raclage rascar	-	445SR 	-
Gips-, Fräsmodele plaster-, Models modèles de plâtre et frais. modelos de yeso y fres.	Vermessen d. Einschubr. measuring of the path insertion mesurer l'axe d'insertion medición de la vía de inserción	-		
Wachs wax cire cera	Fräsen milling fraisage fresar	-	444FR 445FR 	6.000 - 3.000
NEM-Legierungen non-precious alloys	Vorfräsen shaping fraisage gros fresar para formar	X Mittlere X-Verzahnung medium double cut denture croisée moyenne dentado medio cruzado	410RX 408RX 	12.000 - 7.000
alliages non précieux aleaciones non preciosos	Feinfräsen fine milling fraisage de précision fresar de precisión	FX Feine X-Verzahnung fine double cut denture croisée fine dentado fino cruzado	426FFX 408RFX 	12.000 - 7.000
Edelmetall-Legierungen precious metal alloys alliages métalliques pr. aleaciones de metal pr.	Vorfräsen pre-shaping fraisage gros fresar para formar			
NEM-Legierungen non-precious alloys alliages non précieux aleaciones non preciosos	Feinstfräsen super fine milling fraisage de finition fresar de alta precisión	Standard-Verzahnung standard cut denture standard dentado standard	410R 408R 	10.000 - 6.000
	Feinfräsen fine milling fraisage de précision fresar de precisión			
Edelmetall-Legierungen precious metal alloys	Polierfräsen polish milling fraisage de polissage fresas para pulir	H Standard-Verzahn. m. Fase standard cut, chamfer dent. standard avec chanfrein dentado standard con chaflán	410R 408R 	10.000 - 6.000
alliages métalliques pr. aleaciones de metal pr.	Ankörnen centering centrage granetear, centrar	Zentralschneide central cutting edge lame centrale filo cortante central	1 	10.000 - 6.000
	Bohrungen für Retentionsst. drillings for retention areas fraisage p. zones de rétention fresas p. área de retención	Spiral twist helicoïdal helicoïdal	203SHM 	10.000 - 7.000

Der Einsatz von Fräsöl erzielt beim Fräsen eine glattere Werkstückoberfläche, eine Reduzierung der Reibungswärme und eine lange Lebensdauer.
 The use of milling oil while milling, achieves a smoother workpiece surface, a reduction in the friction heat and a long service life.
 L'emploi d'huile de fraisage apporte une surface plus lisse de la pièce à usiner, réduit l'échauffement dû à la friction et prolonge la durée de vie de l'outil.
 Utilizando aceite para fresado se obtienen superficies más lisas de las piezas, se reduce el calor de fricción y se obtiene mayor longevidad.

1

US-No			1/4	1/2	3/4	1	1 1/2	2	3	4	5	6	7	8		10
H/HP/PM	003	004	005	006	007	008	009	010	012	014	016	018	021	023	025	027
ISO 500 104 001 001															•	•

1SXM

US-No	2SXM	3SXM	4SXM	5SXM	6SXM	7SXM	8SXM
H/HP/PM	010	012	014	016	018	021	023
ISO 500 104 001 019...							

mit schlanker Halskonstruktion
 with slender neck construction
 avec la construction du col mince
 con una construcción delgado del cuello

2

US-No	33 1/2		34	34 1/2	35	36	37	38	39	41
H/HP/PM	006	007	008	009	010	012	014	016	018	023
ISO 500 104 010 001...										
L mm	0,5	0,6	0,7	0,8	0,9	1,1	1,2	1,4	1,6	2,0

3

US-No	14
H/HP/PM	012
ISO 500 104 040 001...	
L mm	0,35

Retentionsfräser
 retention cutters
 fraises de rétention
 cierra circular

231

H/HP/PM	023
ISO 500 104 045 001...	
L mm	0,1

für feinste Schnitte in allen Metall-Legierungen
 for finest cuts in all metal alloys
 pour des coupes très fin dans tous les alliages métalliques
 para retenciones muy finas en todas las aleaciones de metales

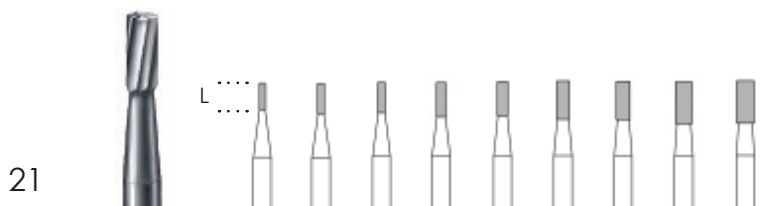

US-No	55	56	57	58	59	60	61	62	63
H/HP/PM	008	009	010	012	014	016	018	021	023
ISO 500 104 107 006...									
L mm	3,5	4,0	4,0	4,5	4,5	5,0	5,0	5,5	5,5

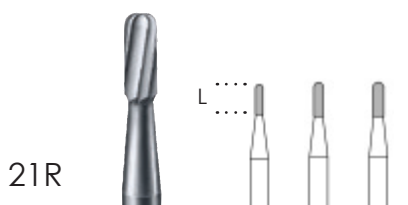

US-No	1157	1158	1159
H/HP/PM	010	012	014
ISO 500 104 137 006...			
L mm	4,0	4,5	4,5



US-No	57L	58L	59L
H/HP/PM	010	012	014
ISO 500 104 110 006...			
L mm	5,5	6,0	6,0

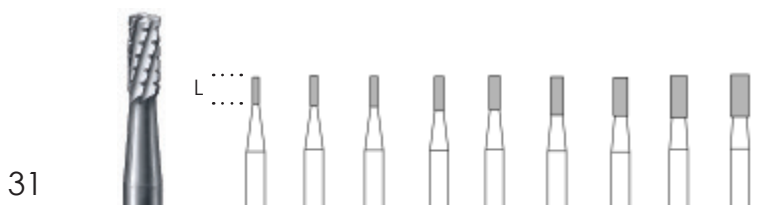

US-No	555	556	557	558	559	560	561	562	563
H/HP/PM	008	009	010	012	014	016	018	021	023
ISO 500 104 107 007...									
L mm	3,5	4,0	4,0	4,5	4,5	5,0	5,0	5,5	5,5

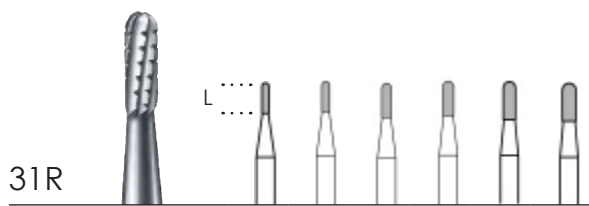

US-No	1556	1557	1558	1559	1560	1561
H/HP/PM	009	010	012	014	016	018
ISO 500 104 137 007...						
L mm	4,0	4,0	4,5	4,5	5,0	5,0



US-No	557L	558L
H/HP/PM	010	012
ISO 500 104 110 007...		
L mm	5,5	6,0

Hartmetall • Kavitäten- und Fissurenbohrer
 Carbide • Excavating and fissure burs
 Carbure • Fraises carbure pour cavités et fraises à fissures
 Carburo • Fresas de carburo excavadoras y fisuras

Zahntechnik
 Dental Technology
 Prothese Dentaire
 Protesis Dental

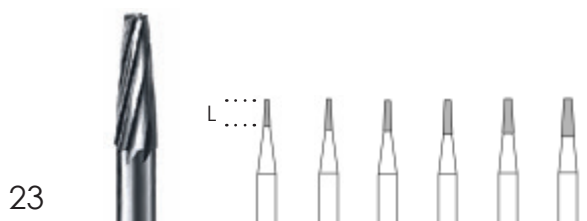

23



US-No	168	169	170	171		172
H/HP/PM	008	009	010	012	014	016
ISO 500 104 168 006...						
L mm	3,5	4,0	4,0	4,5	4,5	5,0

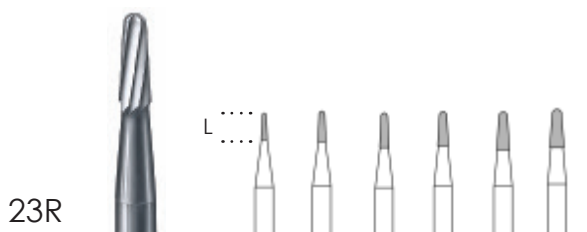

23R



US-No	1168	1170	1171		1172	
H/HP/PM	008	010	012	014	016	018
ISO 500 104 194 006...						
L mm	3,5	4,0	4,5	4,5	5,0	5,5

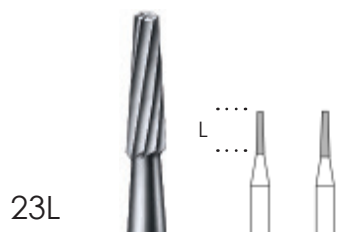

23L



US-No	170L	171L
H/HP/PM	010	012
ISO 500 104 171 006...		
L mm	5,5	6,0

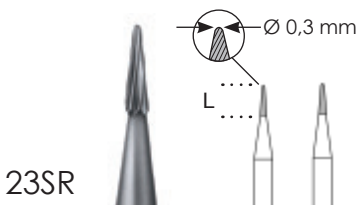

23SR



H/HP/PM	008	010
ISO 500 104 196 006...		
L mm	4,0	4,0



23SRF



H/HP/PM	010
ISO 500 104 196 072...	
L mm	4,0

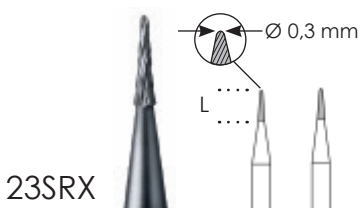

23SRX



H/HP/PM	008	010
ISO 500 104 196 019...		
L mm	4,0	4,0



Hartmetall • Kavitäten- und Fissurenbohrer, Finierer
 Carbide • Excavating and fissure burs, finishing burs
 Carbure • Fraises carbure pour cavités et fraises à fissures, fraises à finir
 Carbuo • Fresas de carburo excavadoras y fisuras, fresas para acabar

33

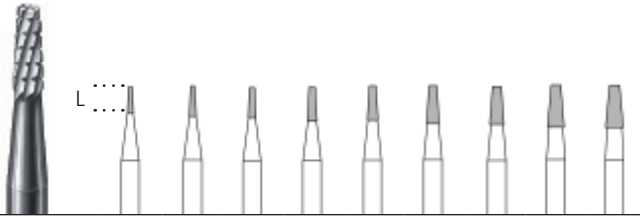

US-No	698	699	700	701		702		703	704
H/HP/PM	008	009	010	012	014	016	018	021	023
ISO 500 104 168 007...									
L mm	3,5	4,0	4,0	4,5	4,5	5,0	5,0	5,5	5,5

33R

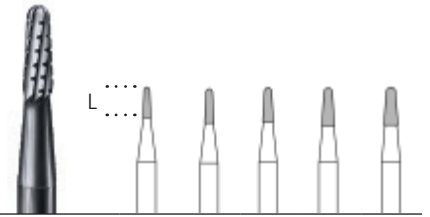

US-No	1700	1701		1702	1703
H/HP/PM	010	012	014	016	018
ISO 500 104 194 007...					
L mm	4,0	4,5	4,5	5,0	5,0

33L



US-No	700L	701L	702L
H/HP/PM	010	012	016
ISO 500 104 171 007...			
L mm	5,5	6,0	6,0

Finierer
 finishing burs
 fraises à finir
 fresas para acabar

41



US-No	7004
H/HP/PM	014
ISO 500 104 001 071...	
L mm	

45

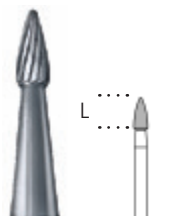

H/HP/PM	018
ISO 500 104 274 072...	
L mm	4,0

Laborfräser, groß

Cutters, large • Fraises, grandes • Fresas, grandes



nasser Modellgips/wet model plaster/plâtre humide/yeso humedo

sehr grobe X-Verzahnung/very coarse double cut/denture croisée très grosse/dentado muy grueso cruzado



SGX



H/HP/PM ISO 500 104...	424SGX 060 263 223 060	424SGX 080 263 223 080		425SGX 060 274 223 060		426SGX 060 137 223 060
L mm	11,0	14,0		14,0		13,0

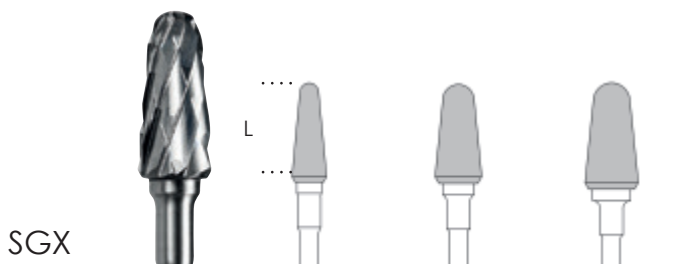

SGX



H/HP/PM ISO 500 104...	429SGX 045 194 223 045	429SGX 060 194 223 060	429SGX 070 194 223 070
L mm	13,0	13,0	14,0



Hartmetall • Fräser, groß
 Carbide • Cutters, large
 Carbure • Fraises, grandes
 Carbuo • Fresas, grandes

nasser Modellgips/wet model plaster/
 plâtre humide/yeso humedo

sehr grobe Verzahnung/very coarse cut/
 denture très grosse/dentado muy grueso



SG



H/HP/PM ISO 500 104...	425SG 060 274 222 060
L mm	14,0

nasser Gips/wet plaster/plâtre humide/yeso humedo

sehr grobe X-Verzahnung, linksgedrallt für erhöhte Sicherheit
 very coarse double cut, left-twisted for increased safety
 denture croisée très grosse avec torsion à gauche pour une plus grande
 sécurité
 dentado muy grueso cruzado con torsión izquierda para mejor seguridad

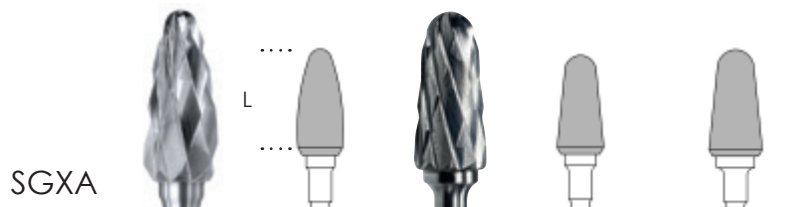

SGXA



H/HP/PM ISO 500 104...	425SGXA 060 274 225 060	429SGXA 060 194 225 060	429SGXA 070 194 225 070
L mm	14,0	13,0	14,0

trockner Modellgips, Kunststoff/dry model, plaster/acrylics plâtre sec/résine/yesos, resina

grobe X-Verzahnung/coarse double cut/denture croisée grosse/dentado grueso cruzado



GX



H/HP/PM ISO 500 104...	424GX 060 263 220 060	424GX 080 263 220 080	425GX 060 274 220 060	426GX 060 137 220 060
L mm	11,0	14,0	14,0	13,0

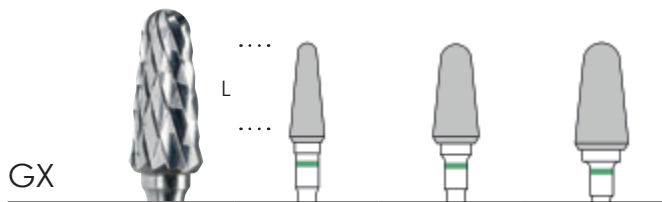

GX



H/HP/PM ISO 500 104...	429GX 045 194 220 045	429GX 060 194 220 060	429GX 070 194 220 070
L mm	13,0	13,0	14,0

Hartmetall • Fräser, groß
 Carbide • Cutters, large
 Carbure • Fraises, grandes
 Carbuo • Fresas, grandes

Zahntechnik
 Dental Technology
 Prothese Dentaire
 Protesis Dental

grobe Verzahnung/coarse cut/denture grosse/dentado grueso



G



H/HP/PM ISO 500 104...	424G 080 263 215 080	425G 060 274 215 060	429G 045 194 215 045
L mm	14,0	14,0	13,0

trockener Gips, Kunststoff/dry plaster, acrylic/plâtre sec, résine/yeso seco, resina

grobe X-Verzahnung, linksgedraht für erhöhte Sicherheit/coarse double cut, left-twisted for increased safety
 denture croisée grosse avec torsion à gauche pour une plus grande sécurité/dentado grueso cruzado con torsión izquierda para mejor seguridad

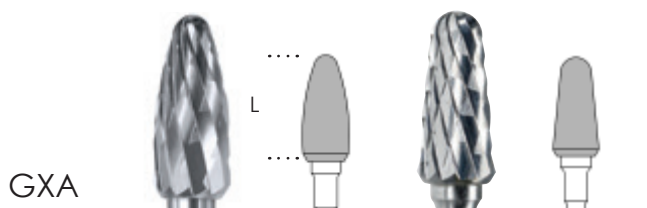

GXA



H/HP/PM ISO 500 104...	425GXA 060 274 221 060	429GXA 060 194 221 060
L mm	14,0	13,0

weichbleibende Kunststoffe (Unterfütterungen)/non-hardening acrylics (relinings)
 résine molle (rebasage)/materiales de rebases blandos y cubetas

grobe gerade Verzahnung Querhieb/coarse straight cut cross cut
 denture droite grosse avec taille transversale/dentado grueso recto y corte transversal

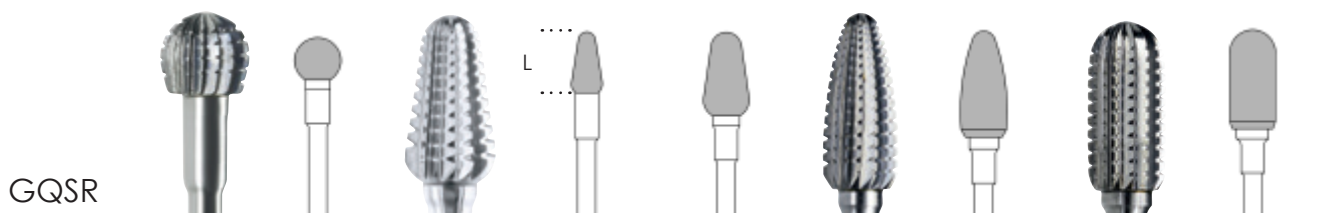

GQSR



H/HP/PM ISO 500 104...	421GQSR 060 001 212 060	424GQSR 040 263 212 040	424GQSR 060 263 212 060	425GQSR 060 274 212 060	426GQSR 060 137 212 060
L mm		8,0	11,0	14,0	13,0

weiche Kunststoffe (Schienen)/soft acrylics (splints)/résine molle (gouttière)/resinas blandas (rieles)

mittlere Verzahnung mit Querhieb/medium cut with cross cut/denture moyenne avec taille transv./dentado medio con corte transversal



MQS



H/HP/PM ISO 500 104...	424MQS 060 263 216 060	425MQS 060 274 216 060	426MQS 060 137 216 060	429MQS 040 194 216 040	433MQS 023 194 216 023
L mm	11,0	14,0	13,0	13,0	12,0

Synth. Gips, Kunststoff/synthetic plaster, acrylic/plâtre synthétique, résine/yeso sintético, resina

mittlere Verzahnung/medium cut/denture moyenne/dentado medio



H/HP/PM ISO 500 104...	421 031 001 175 031	421 040 001 175 040	421 050 001 175 050	424 040 263 175 040	424 060 263 175 060	425 040 274 175 040	425 060 274 175 060
L mm	2,8	3,5	4,4	8,0	11,0	11,5	14,0



H/HP/PM ISO 500 104...	426 023 137 175 023	426 060 137 175 060	427 060 237 175 060	428 060 257 175 060	429 031 194 175 031	429 045 194 175 045	429 060 194 175 060
L mm	15,0	13,0	11,0	12,0	11,5	13,0	13,0

Hartmetall • Fräser, groß
 Carbide • Cutters, large
 Carbure • Fraises, grandes
 Carbuo • Fresas, grandes

Zahntechnik
 Dental Technology
 Prothese Dentaire
 Protesis Dental

H/HP/PM ISO 500 104...	432 023 201 175 023	433 023 194 175 023	433 060 201 175 060
L mm	14,5	12,0	14,0

Stichfräser mit 4-kant Arbeitsteil/pointed cutter with a 4-sided working part
 fraise en pointue avec 4 pans/fresa de punta con 4 cortantes

515

H/HP/PM ISO 500 104...	515 023 467 211 023	
L mm	11,0	

für die Bearbeitung von thermoplastischen Tiefziehteilen
 for processing thermoplastic deep-drawing parts
 pour pièces d'emboutissage profond thermoplastique
 para piezas de embutación profunda termoplásticas

Titan/titanium/titane/titanio

mittlere X-Verzahnung
 medium double cut
 denture croisée moyenne
 dentado medio cruzado

XTi

H/HP/PM	429XTi 040
L mm	13,0

Keramik, Komposit/ceramic, composite

céramique, composite/cerámica, composite

feine X-Verzahnung
 fine double cut
 denture croisée fine
 dentado fino cruzado

FXK

H/HP/PM	432FXK 023
L mm	14,5

Synth. Gips, Prothesen-Kunststoff Löffelkunststoff, Au-, Ag-, Pd-Leg., CrCo-, NiCr-Leg.
 synthetic plaster, denture resin, individual tray Au-, Ag-, Pd-Alloy, CrCo-, NiCr-Alloy
 plâtre synthétique, résine pour prothèse amovible Au-, Ag-, Pd-Alliage, CrCo-, NiCr-Alliage
 yeso sintético, resina para removibles y ortod. cubetas acr., Au-, Ag-, Pd-Al., CrCo-, NiCr-Al.

mittlere X-Verzahnung/medium double cut/denture croisée moyenne/dentado medio cruzado

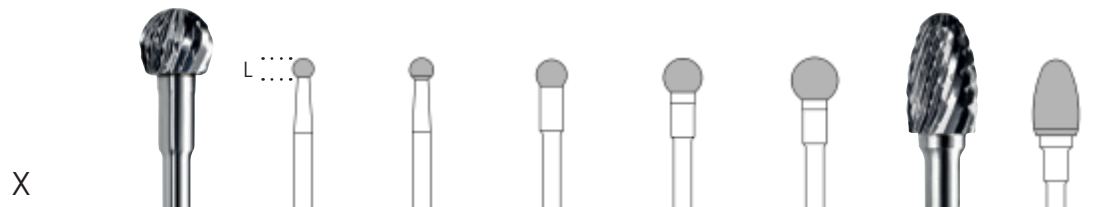

X



H/HP/PM ISO 500 104...	421X 027 001 190 027	421X 031 001 190 031	421X 040 001 190 040	421X 050 001 190 050	421X 060 001 190 060		423X 060 277 190 060
L mm	2,5	2,8	3,5	4,4	5,5		10,0

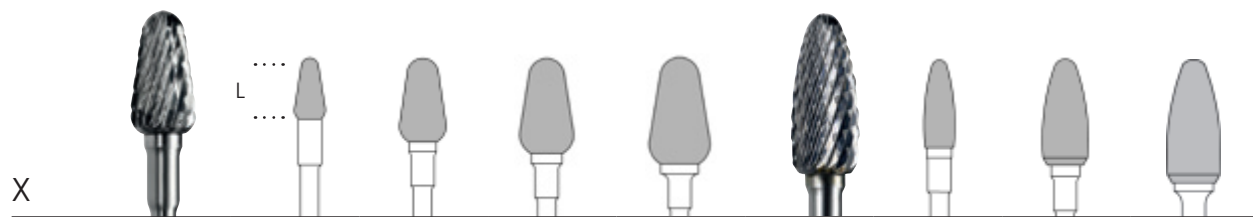

X



H/HP/PM ISO 500 104...	424X 040 263 190 040	424X 060 263 190 060	424X 070 263 190 070	424X 080 263 190 080		425X 040 274 190 040	425X 060 274 190 060	425X 070 274 190 070
L mm	8,0	11,0	12,5	14,0		11,5	14,0	16,0



X



H/HP/PM ISO 500 104...	426X 060 137 190 060		427X 029 237 190 029	427X 060 237 190 060		428X 060 257 190 060
L mm	13,0		5,5	11,0		12,0

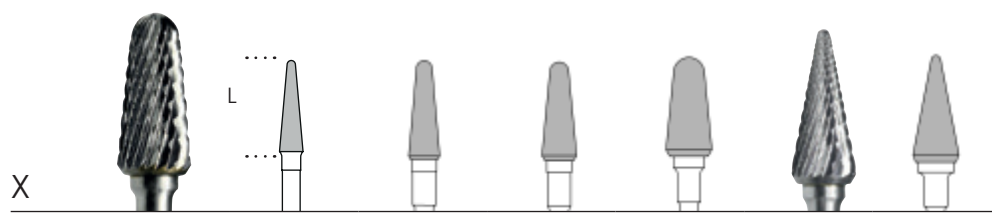

X



H/HP/PM ISO 500 104...	429X 031 194 190 031	429X 040 194 190 040	429X 045 194 190 045	429X 060 194 190 060		433X 060 201 190 060
L mm	11,5	13,0	13,0	13,0		14,4

Hartmetall • Fräser, groß
 Carbide • Cutters, large
 Carbure • Fraises, grandes
 Carburo • Fresas, grandes

Zahntechnik
 Dental Technology
 Prothese Dentaire
 Protesis Dental



H/HP/PM ISO 500 104...	426X 023 137 190 023	428X 023 257 190 023	431X 023 116 190 023	432X 023 201 190 023	433X 023 194 190 023
L mm	15,00	15,00	15,00	14,50	12,00

Synth. Gips, Kunststoff Au-, Ag-, Pd-Leg., CrCo-, NiCr-Leg.
 synthetic plaster, acrylic Au-, Ag-, Pd-Alloy, CrCo-, NiCr-Alloy
 plâtre synthétique, résine Au-, Ag-, Pd-Alliage, CrCo-, NiCr-Alliage
 yeso sintético, resina Au-, Ag-, Pd-Al., CrCo-, NiCr-Al.

feine X-Verzahnung/fine double cut/denture croisée fine/dentado fino cruzado

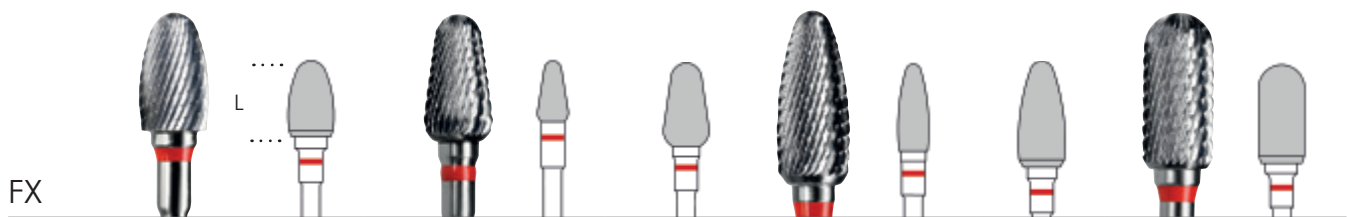

H/HP/PM ISO 500 104...	423FX 060 277 140 060	424FX 040 263 140 040	424FX 060 263 140 060	425FX 040 274 140 040	425FX 060 274 140 060	426FX 060 137 140 060
L mm	10,0	8,0	11,0	11,5	14,0	13,0

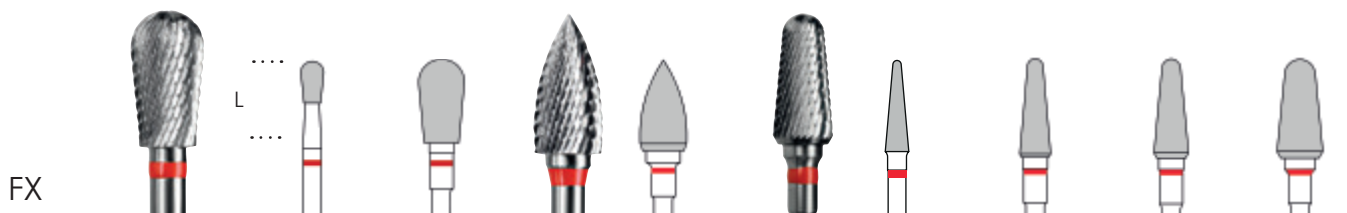

H/HP/PM ISO 500 104...	427FX 029 237 140 029	427FX 060 237 140 060	428FX 060 257 140 060	429FX 031 194 140 031	429FX 040 194 140 040	429FX 045 194 140 045	429FX 060 194 140 060
L mm	5,5	11,0	12,0	11,5	13,0	13,0	13,0



H/HP/PM ISO 500 104...	426FX 023 137 140 023	428FX 023 257 140 023	431FX 023 116 140 023	432FX 023 201 140 023	433FX 023 194 140 023
L mm	15,0	15,0	15,0	14,5	12,0

Keramik, Titan, Komposit Au-, Ag-, Pt-Leg./ceramic, titanium, composite Au-, Ag-, Pt-Alloy
 céramique, titane, composite Au-, Ag-, Pt-All./cerámica, titanio, composite Au-, Ag-, Pt-Al.

sehr feine X-Verzahnung/super-fine double cut/denture croisée très fine/dentado superfino cruzado

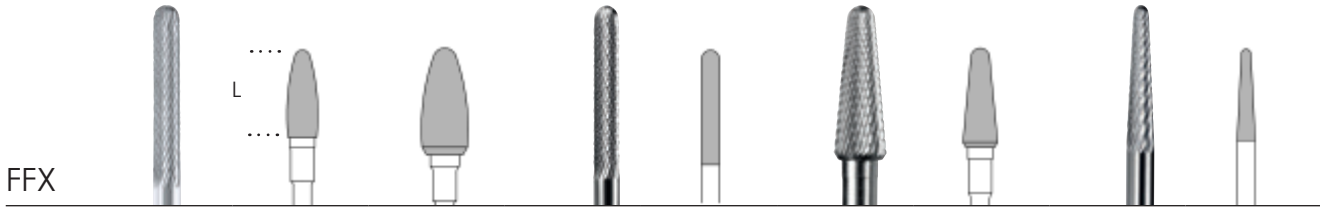

FFX



H/HP/PM ISO 500 104...	425FFX 040 274 110 040	425FFX 060 274 110 060		426FFX 023 137 110 023		429FFX 045 194 110 045		433FFX 023 194 110 023
L mm	11,5	14,0		15,0		13,0		12,0

Linkshänder-Fräser
 left-handed cutter
 fraise pour gaucher
 fresa para zurdos

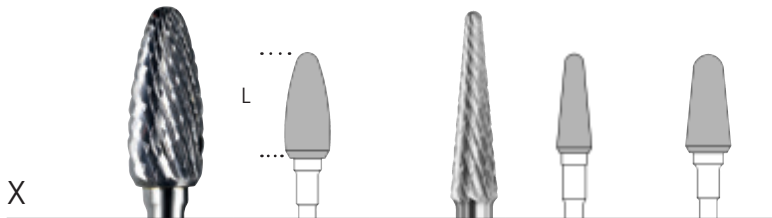

X



H/HP/PM ISO 500 104...	425X 060L 274 192 060		429X 045L 194 192 045	429X 060L 194 192 060
L mm	14,0		13,0	13,0



FX



H/HP/PM ISO 500 104...	425FX 060L 274 142 060		429FX 045L 194 142 045	429FX 060L 194 142 060
L mm	14,0		13,0	13,0

MIDIS & SHORTIES

Laborfräser, klein

Cutters, small • Carubre, petites • Carburo, pequeño



Arbeitsteillänge
herkömmlicher
Hartmetall-Fräser
working part length
of conventional
carbide cutters
longeur de la partie
travaillante des
fraises en carbure
longitud de fresas
de carburo



Arbeitsteillänge
der MIDIS
working part
length of
MIDIS
longeur de la
partie travaillante
des MIDIS
longitud de la parte
activa de MIDIS



Arbeitsteillänge
der SHORTIES
working part length
of SHORTIES
longeur de la
partie travaillante
des SHORTIES
longitud de la parte
activa de SHORTIES

Schlau ist, wer den Preisvorteil geringerer
Material- und Fertigungskosten nutzt!
Es gilt: Je kürzer das Arbeitsteil, desto höher der
Preisvorteil.
Entscheiden Sie wie viel Sie sparen wollen.

Est intelligent quiconque tire profit de l'avantage
de prix procuré par de moindres coûts de matéri-
aux et de production. Prévaute: Plus la partie travail-
lante est courte, plus l'avantage de prix est élevé.
Décidez vous-mêmes de l'économie que vous
souhaitez réaliser.

Think smart and benefit from the price advan-
tage of low material and manufacturing costs!
It holds true: The shorter the working part, the
higher the price advantage.
You can decide how much you want to save.

¡Astuto es el que utiliza la ventaja de precio con
menor coste de material y fabricación!
Se aplica lo siguiente: cuanto más corta sea la
parte activa, más económico será el precio.
Decida usted mismo cuánto desea ahorrar.

weichbleibende Kunststoffe (Unterfütterungen)/non-hardening acrylics (relinings)
résine molle (rebasage)/materiales de rebases blandos y cubetas

grobe grade Verzahnung Querhieb/coarse straight cut cross cut
denture droite grosse avec taille transversale/dentado grueso recto y corte transversal



GQSR
MIDIS



H/HP/PM ISO 500 104...	M426GQSR 023 141 212 023	M433GQSR 016 198 212 016	M433GQSR 023 198 212 016
L mm	8,5	7,5	8,5



Hartmetall • Fräser, klein/MIDIS
 Carbide • Cutters, small/MIDIS
 Carbure • Fraises, petites/MIDIS
 Carbuo • Fresas, pequeñas/MIDIS

weiche Kunststoffe (Schienen)/soft acrylics (splints)/résine molle (gouttière)/resinas blandas (rieles)

mittlere Verzahnung mit Querhieb/medium cut with cross cut/denture moyenne avec taille trans./dentado medio con corte trans.

MQS
MIDIS

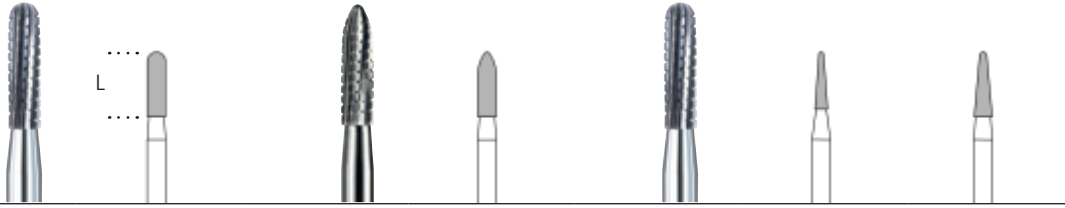

H/HP/PM ISO 500 104...	M426MQS 023 141 216 023	M428MQS 023 289 216 023	M433MQS 016 198 216 016	M433MQS 023 198 216 023
L mm	8,5	8,5	7,5	8,5

Titan/titanium/titane/titanio

X-Verzahnung - speziell für Titan
 double cut - special for titanium
 denture croisée - spécial pour le titane
 dentado cruzado - especialmente para el titanio

XTi
MIDIS

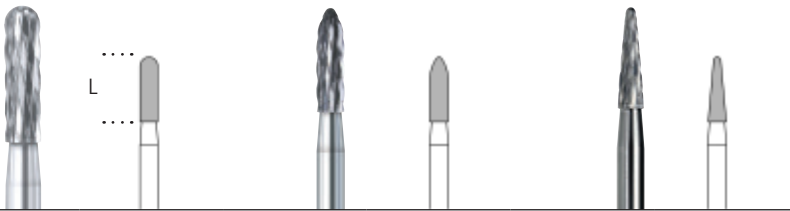

H/HP/PM	M426XTi 023	M428XTi 023	M433XTi 023
L mm	8,5	8,5	8,5

Keramik, Komposit/ceramic, composite/céramique, composite/cerámica, composite

feine X-Verzahnung/fine double cut/denture croisée fine/dentado fino cruzado

FXK
MIDIS



H/HP/PM	M426FXK 023	M428FXK 023	M433FXK 023
L mm	8,5	8,5	8,5

Hartmetall • Fräser, klein/MIDIS
 Carbide • Cutters, small/MIDIS
 Carbure • Fraises, petites/MIDIS
 Carburo • Fresas, pequeñas/MIDIS

Zahntechnik
 Dental Technology
 Prothese Dentaire
 Protesis Dental

Synth. Gips, Prothesen-Kunststoff Löffelkunststoff, Au-, Ag-, Pd-Leg., CrCo-, NiCr-Leg.
 synthetic plaster, denture resin, individual tray Au-, Ag-, Pd-Alloy, CrCo-, NiCr-Alloy
 plâtre synthétique, résine pour prothèse amovible Au-, Ag-, Pd-Alliage, CrCo-, NiCr-Alliage
 yeso sintético, resina para removibles y ortod. cubetas acr., Au-, Ag-, Pd-Al., CrCo-, NiCr-Al.

mittlere X-Verzahnung/medium double cut/denture croisée moyenne/dentado medio cruzado

**X
MIDIS**

ISO 500 104...

H/HP/PM	M426X 016	M426X 023	M428X 016	M428X 023	M433X 016	M433X 023
ISO 500 104...	141 190 016	141 190 023	289 190 016	289 190 023	198 190 016	198 190 023
L mm	7,5	8,5	7,5	8,5	7,5	8,5

Synth. Gips, Kunststoff Au-, Ag-, Pd-Leg., CrCo-, NiCr-Leg./
 synthetic plaster, acrylic Au-, Ag-, Pd-Alloy, CrCo-, NiCr-Alloy
 plâtre synthétique, résine Au-, Ag-, Pd-Alliage, CrCo-, NiCr-Alliage
 yeso sintético, resina Au-, Ag-, Pd-Al., CrCo-, NiCr-Al.

feine X-Verzahnung/fine double cut/denture croisée fine/dentado fino cruzado

**FX
MIDIS**

ISO 500 104...

H/HP/PM	M426FX 016	M426FX 023	M428FX 016	M428FX 023	M433FX 016	M433FX 023
ISO 500 104...	141 140 016	141 140 023	289 140 016	289 140 023	198 140 016	198 140 023
L mm	7,5	8,5	7,5	8,5	7,5	8,5

Keramik, Titan, Komposit Au-, Ag-, Pt-Leg./ceramic, titanium, composite Au-, Ag-, Pt-Alloy
 céramique, titane, composite Au-, Ag-, Pt-All./cerámica, titanio, composite Au-, Ag-, Pt-Al.

sehr feine X-Verzahnung/super-fine double cut/denture croisée très fine/dentado superfino cruzado

**FFX
MIDIS**

ISO 500 104...

H/HP/PM	M426FFX 016	M426FFX 023	M428FFX 016	M428FFX 023	M433FFX 016	M433FFX 023
ISO 500 104...	141 110 016	141 110 023	289 110 016	289 110 023	198 110 016	198 110 023
L mm	7,5	8,5	7,5	8,5	7,5	8,5



Hartmetall • Fräser, klein/SHORTIES
 Carbide • Cutters, small/SHORTIES
 Carbure • Fraises, petites/SHORTIES
 Carburo • Fresas, pequeñas/SHORTIES

weiche Kunststoffe (Schiene)n/soft acrylics (splints)/résine molle (gouttière)/resinas blandas (rieles)

mittlere Verzahnung mit Querhieb/medium cut with cross cut/denture moyenne avec taille transv./dentado medio con corte transversal

MQS
SHORTIES



H/HP/PM	S423MQS 014	S427MQS 023
ISO 500 104...	277 216 014	277 216 023
L mm	2,9	5,5

Titan/titanium/titane/titanio

mittlere X-Verzahnung/medium double cut
 denture croisée moyenne/dentado medio cruzado

XTi
SHORTIES

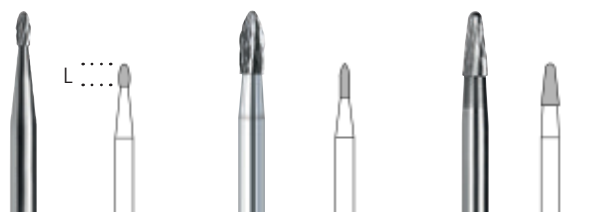

H/HP/PM	S423XTi 014	S428XTi 012	S433XTi 023
ISO 500 104...			
L mm	2,9	4,5	5,5

Keramik, Komposit
 ceramic, composite
 céramique, composite
 cerámica, composite

feine X-Verzahnung/fine double cut/denture
 croisée fine/dentado fino cruzado

FXK
SHORTIES

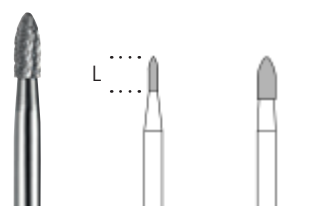

H/HP/PM	S428FXK 012	S428FXK 023
ISO 500 104...		
L mm	4,5	5,5

Synth. Gips, Prothesen-Kunststoff Löffelkunststoff, Au-, Ag-, Pd-Leg., CrCo-, NiCr-Leg.

synthetic plaster, denture resin, individual tray Au-, Ag-, Pd-Alloy, CrCo-, NiCr-Alloy

plâtre synthétique, résine pour prothèse amovible Au-, Ag-, Pd-Alliage, CrCo-, NiCr-Alliage

yeso sintético, resina para removibles y ortod. cubetas acr., Au-, Ag-, Pd-Al., CrCo-, NiCr-Al.

mittlere X-Verzahnung/medium double cut/denture croisée moyenne/dentado medio cruzado

X
SHORTIES

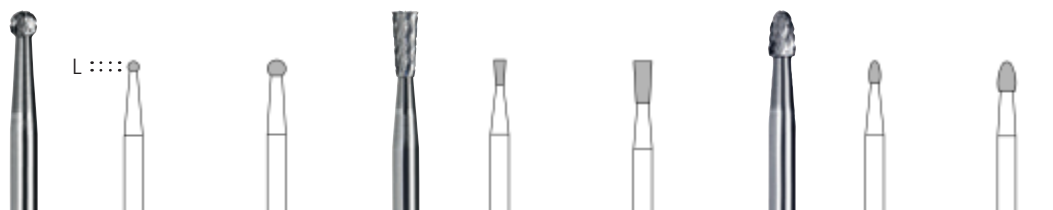

H/HP/PM	S421X 014	S421X 023	S422X 014	S422X 023	S423X 014	S423X 023
ISO 500 104...	001 190 014	001 190 023	225 190 014	225 190 023	277 190 014	277 190 023
L mm	1,2	2,1	3,3	5,5	2,9	3,8

Hartmetall • Fräser, klein/SHORTIES
 Carbide • Cutters, small/SHORTIES
 Carbure • Fraises, petites/SHORTIES
 Carburo • Fresas, pequeñas/SHORTIES

Zahntechnik
 Dental Technology
 Prothese Dentaire
 Protesis Dental



X
SHORTIES



H/HP/PM ISO 500 104...	S426X 014 140 190 014	S426X 023 140 190 023	S427X 023 237 190 023	S428X 023 288 190 023	S430X 023 243 190 023
L mm	4,5	5,5	5,5	5,5	5,5

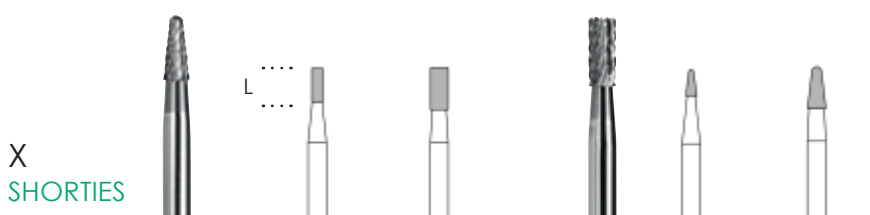

X
SHORTIES



H/HP/PM ISO 500 104...	S431X 014 110 191 014	S431X 023 110 191 023	S433X 014 197 190 014	S433X 023 197 190 023
L mm	4,5	5,5	3,5	5,5

Synth. Gips, Kunststoff Au-, Ag-, Pd-Leg., CrCo-, NiCr-Leg.
 synthetic plaster, acrylic Au-, Ag-, Pd-Alloy, CrCo-, NiCr-Alloy
 plâtre synthétique, résine Au-, Ag-, Pd-Alliage, CrCo-, NiCr-Alliage
 yeso sintético, resina Au-, Ag-, Pd-Al., CrCo-, NiCr-Al.

feine X-Verzahnung/fine double cut/denture croisée fine/dentado fino cruzado

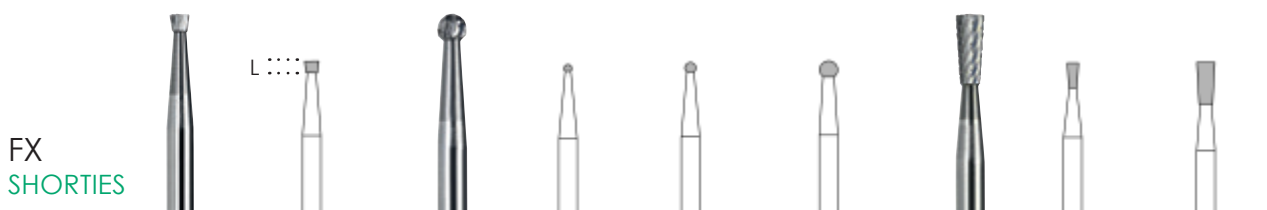

FX
SHORTIES



H/HP/PM ISO 500 104...	S420FX 018 010 140 018	S421FX 010 001 140 010	S421FX 014 001 140 014	S421FX 023 001 140 023	S422FX 014 225 140 014	S422FX 023 225 140 023
L mm	1,4	0,8	1,2	2,1	3,3	5,5



FX
SHORTIES



H/HP/PM ISO 500 104...	S423FX 014 277 140 014	S423FX 023 277 140 023	S426FX 014 140 140 014	S426FX 023 140 140 023	S427FX 023 237 140 023	S428FX 023 288 140 023
L mm	2,9	3,8	4,5	5,5	5,5	5,5

feine X-Verzahnung/fine double cut/denture croisée fine/dentado fino cruzado



FX
SHORTIES



H/HP/PM ISO 500 104...	S430FX 023 243 140 023	S431FX 014 110 140 014	S431FX 023 110 140 023	S433FX 014 197 140 014	S433FX 023 197 140 023
L mm	5,5	4,5	5,5	3,5	5,5

Keramik, Titan, Komposit Au-, Ag-, Pt-Leg./ceramic, titanium, composite Au-, Ag-, Pt-Alloy
 céramique, titane, composite Au-, Ag-, Pt-All./cerámica, titanio, composite Au-, Ag-, Pt-All.

sehr feine X-Verzahnung/super-fine double cut/denture croisée très fine/dentado superfino cruzado

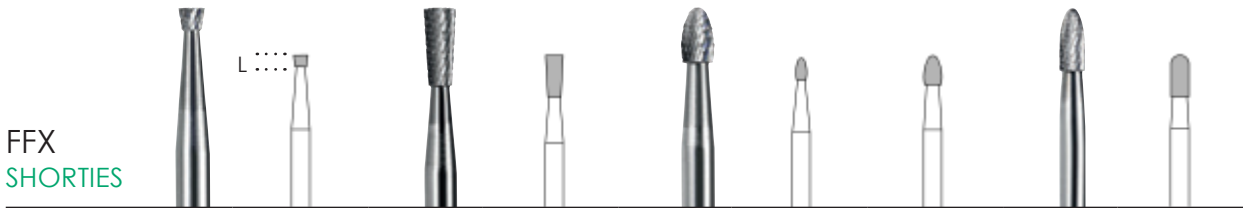

FFX
SHORTIES



H/HP/PM ISO 500 104...	S420FFX 018 010 110 018	S422FFX 023 225 110 023	S423FFX 014 277 110 014	S423FFX 023 277 110 023	S426FFX 023 140 110 023
L mm	1,4	5,5	2,9	3,8	5,5



FFX
SHORTIES



H/HP/PM ISO 500 104...	S427FFX 023 237 110 023	S428FFX 023 288 110 023	S433FFX 014 197 110 014	S433FFX 023 197 110 023
L mm	5,5	5,5	3,5	5,5

Frästechnik

milling technique • technique de fraisage
técnica de fresado



Parallel-Wachsfräser
parallel wax cutter
fraise à cire parallèle
fresa paralela para cera

Konus Wachsfräser
cone shape wax cutter
fraise à cire conique
fresa cónica para cera

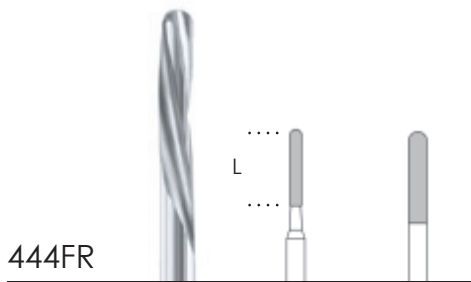

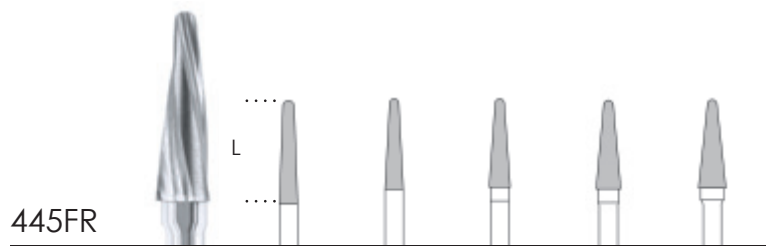

444FR

 		
H-kurz/HP short PM courte/PM corta	015	023
ISO 500 103...	143 377 015	143 337 023
		
L mm	10,0	12,0





445FR

 					
H-kurz/HP short PM courte/PM corta	2°	3°	4°	5°	6°
ISO 500 103...	201 377 023	200 377 023	200 377 028	200 377 032	200 377 036
					
L mm	13,6	11,9	11,4	11,4	11,4

Konus Wachsschaber
cone shape wax scaler
grattoir à cire conique
raspadores cónicos para cera

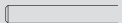

445SR

 				
H-kurz/HP short PM courte/PM corta	3°	4°	5°	6°
ISO 500 103...	186 375 023	186 375 028	186 375 032	186 375 036
				
L mm	11,9	11,4	11,4	11,4

grobfräsen/rough-out/fraisage gros/fresar previamente

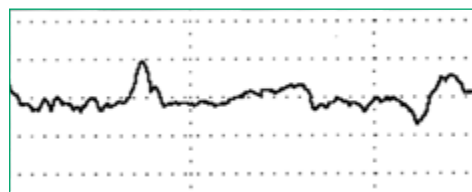
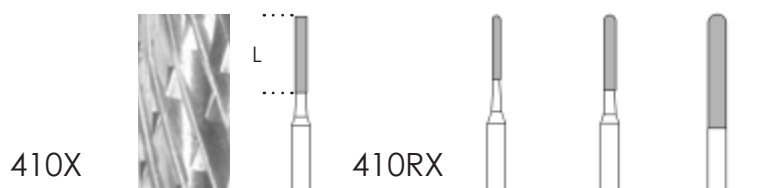

H-kurz/HP short PM courte/PM corta ISO 500 103...	015	010	015	023
	116 190 015	137 190 010	137 190 015	137 190 023
L mm	10,0	8,5	10,0	15,0

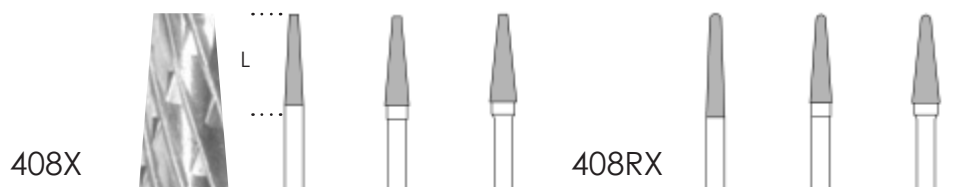

H-kurz/HP short PM courte/PM corta ISO 500 103...	3°	5°	6°	2°	4°	6°
	186 190 023	186 190 032	186 190 036	201 190 023	200 190 028	200 190 036
L mm	12,0	11,7	11,7	13,6	11,6	11,6

vorfräsen/pre-shaping/fraisage moyen/fresar para formar

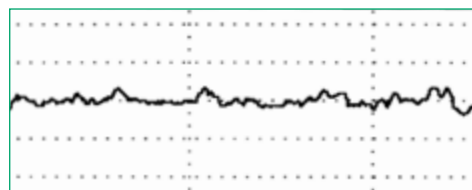
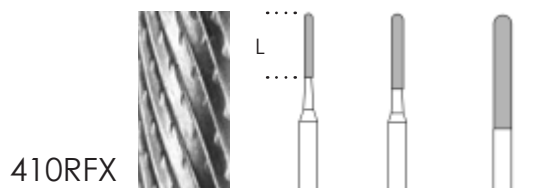

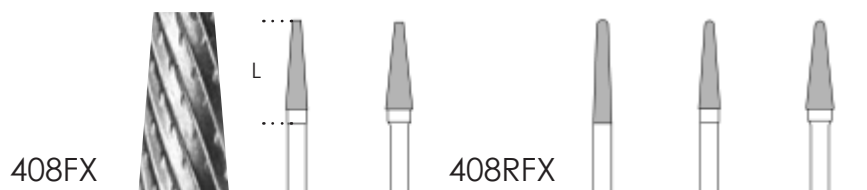

H-kurz/HP short PM courte/PM corta ISO 500 103...	010	015	023
	137 140 010	137 140 015	137 140 023
L mm	8,5	10,0	15,0



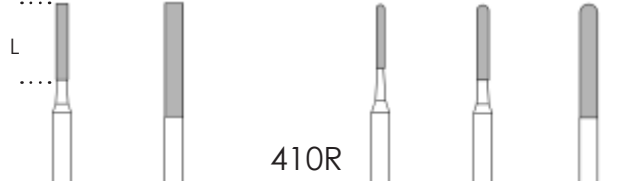
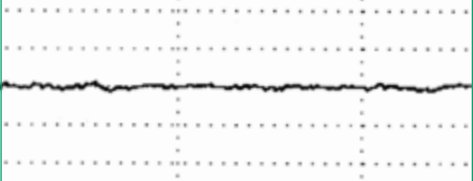

H-kurz/HP short PM courte/PM corta ISO 500 103...	4°	6°	2°	4°	6°
	187 143 028	187 143 036	201 143 023	200 143 028	200 143 036
L mm	11,7	11,7	13,6	11,6	11,6

feinfräsen/fine milling/fraisage de précision/fresar de precisión

410   **410R** 



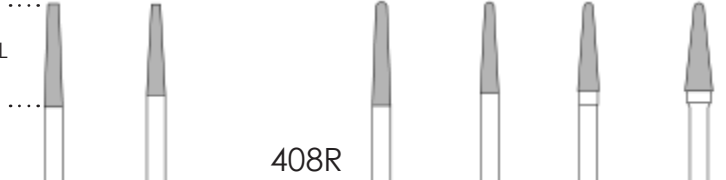

H-kurz/HP short PM courte/PM corta ISO 500 103...	015	023	010	015	023
	116 135 015	116 135 023	137 135 010	137 135 015	137 135 023
L mm	10,0	15,0	8,5	10,0	15,0

408   **408R** 



H-kurz/HP short PM courte/PM corta ISO 500 103...	2°	3°	2°	3°	4°	6°
	187 135 023	186 135 023	201 135 023	200 135 023	200 135 028	200 135 036
L mm	13,6	12,0	13,6	12,0	11,6	11,6

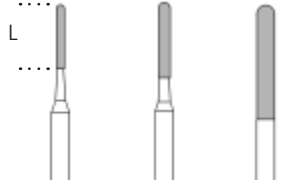
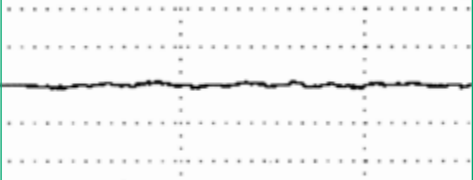

feinstfräsen/super fine milling/fraisage de finition/fresar de alta precisión

410RH    

Fasenverzahnung
 Backside chamfered cut
 Denture avec chanfrein
 Dentado con chafán

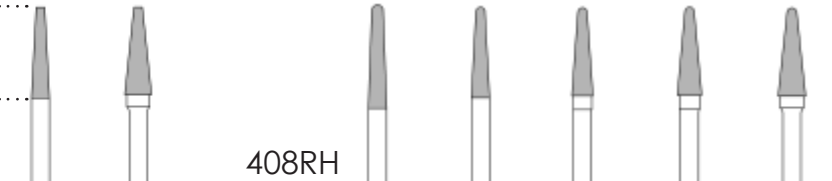

H-kurz/HP short PM courte/PM corta ISO 500 103...		010	015	023
		137 103 010	137 103 015	137 103 023
L mm		8,5	10,0	15,0

408H   **408RH** 



H-kurz/HP short PM courte/PM corta ISO 500 103...	3°	6°	2°	3°	4°	5°	6°
	186 103 023	186 103 036	201 103 023	200 103 023	200 103 028	200 103 032	200 103 036
L mm	12,0	11,7	13,60	12,0	11,6	11,6	11,6

Spezial Spiralbohrer
 special twistdrill
 foret hélicoïdal spécial
 fresa helicoidal especial

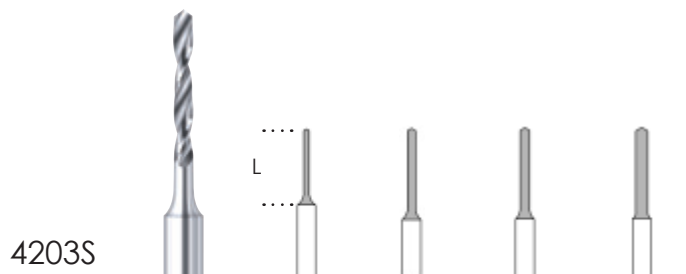

4203S



H-kurz/HP short PM courte/PM corta ISO 500 103...	007	010	012	015
	417 364 007	417 364 010	417 364 012	417 364 015
L mm	10,0	12,0	12,0	12,0

Körnerbohrer
 centering bur
 fraise de centrage
 fresa de centraje

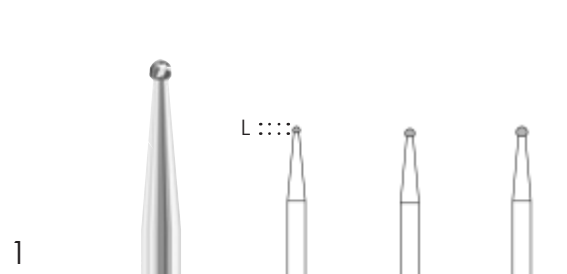

1



H-kurz/HP short PM courte/PM corta ISO 500 103...	009	012	014
	001 001 009	001 001 012	001 001 014
L mm	0,8	1,0	1,2

Rillenfräser
 grooving cutter
 fraise à rainures
 fresa para ranuras

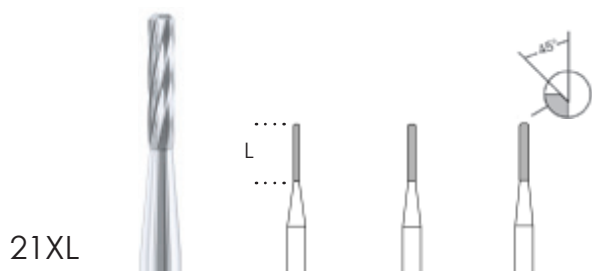

21XL



H-kurz/HP short PM courte/PM corta ISO 500 103...	007	010	012
	538 175 007	538 175 010	538 175 012
L mm	7,5	7,5	7,5

Schulterfräser
 shoulder cutter
 fraise à épaulement
 fresa para hombros

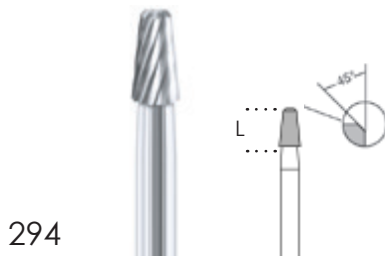

294



H-kurz/HP short PM courte/PM corta ISO 500 103...	6° 027 205 175 027
L mm	5,0

Ankerfräser (Knopfankertechnik)
 anchor cutter (Push-button attachment)
 fraise d'ancrage (Attachement bouton-pression)
 fresas de anclaje (Anclaje botón pulsador)

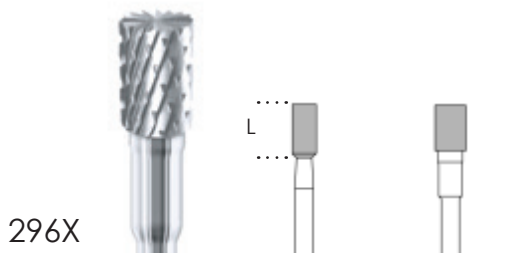

296X



H/HP/PM	031	040
ISO 500 104...	110 190 031	110 190 040
L mm	7,0	6,0

Zahntechnik

Dental Technology • Prothese Dentaire • Prothesis Dental





Keramik

Ceramic • Céramique • Cerámica

Fräser für Kunststoffe und Zirkonoxid-Weißlinge
Cutters for acrylics and pre-sintered zirconia
Fraises pour la résine et la zircone non frittée
Fresas para resinas y dióxido de zirconio presinterizada

126+127

Einsatzgebiet used on domaine d'application uso en sector	Arbeitsgang working process phase de travail fase de trabajo	Verzahnungsart type of cuts type de denture tipos de dentado	Instrumentenbeispiel examples of instr. exempl. d'instruments ej. de los instrumentos	ISO-Ø	empf. Drehzahl min ⁻¹ recom. speed r.p.m. vit. de rotation rec. veloc. recomendada
Kunststoffe (weichbleibende und weiche) Zirkon-Weißlinge acrylics (non-hardening and soft) pre-sintered zirconia résines acryliques (flexibles et molles) pour la zircone pre-filtrée resinas acrílicas (flexibles y blandas) para la zirconia presinterizada	Ausarbeiten work out ajustage repasado	GQSR Grobe gerade schnittfr. Verzahnung mit Querhieb coarse straight power cut/ with cross-cut denture droite grosse sécante avec taille transversale dentado grueso recto con corte transversal	K424GQSR/060 	023-060	15.000
Kunststoffe Zirkon-Weißlinge acrylics pre-sintered zirconia	Ausarbeiten, Formfräsen work out, shape milling ajustage, façonnage par frais. fresar y formar	X Mittlere X-Verzahnung medium double cut denture croisée moyenne dentado medio cruzado	K429X/060 	016-023	15.000
zircone pre-filtrée zirconia presinterizada	Korrekturen, Feinbearbeitung adjustments, fine finishing corrections, finition correcciones, trabajos de precisión	FX Feine X-Verzahnung fine double cut denture croisée fine dentado fino cruzado	K423FX/023 	014-023	15.000

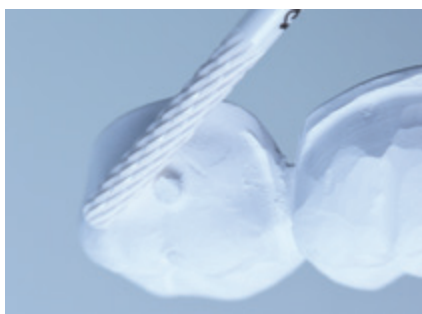

Das bestehende KERA-Sortiment wurde um acht neue filigrane Formen ergänzt, die komplett aus Keramik gefertigt sind und für hervorragende Ergebnisse, glatte Oberflächen und ein angenehmes thermisches Verhalten sorgen.

Die spezielle weiße Hochleistungskeramik ist 25% bis 60% leichter als Hartmetall und ermöglicht so ein schonenderes Fräsen.

The existing KERA range has been complemented by eight new filigree shapes entirely made of ceramic for excellent results, smooth surfaces and a pleasant thermal behaviour.

The special white high-performance ceramic is between 25% to 60% lighter than carbide, thus permitting more gentle cutting.

La gamme KERA existante a été complétée par huit nouvelles formes délicates entièrement fabriquées en céramique garantissant des résultats exceptionnels, des surfaces lisses et un comportement thermique agréable.

La céramique haute performance blanche spéciale est 25 % à 60 % plus légère que le carbure et permet un fraisage plus délicat.

Ocho formas nuevas de cerámica pura agregan la serie KERA.

Las fresas garantizan excelentes resultados, superficies lisas y un comportamiento térmico agradable. La cerámica blanca es un material de tecnología alta y de alto rendimiento.

Debido al material muy especial el peso es entre un 25 % hasta un 60 % más ligero que el carburo de tungsteno; por eso permite un fresado más suave.

Feine X-Verzahnung/fine double cut/fine denture croisée/dentado fino cruzado



FX



H/HP/PM	K423FX 014	K423FX 023
	*	*
L mm	2,9	3,8

Mittlere X-Verzahnung/medium double cut/denture croisée moyenne/dentado medio cruzado

Kunststoffe: Ausarbeiten, Formfräsen
 Zirkonoxid-Weißlinge: Trennen, Verputzen von Ansatzstellen und Herausstrennen von Zirkonoxid-Weißlingen aus dem Blank

acrylics: processing and shape milling
 pre-sintered zirconia: separating, cleaning the point of attachment and removal of pre-sintered zirconia from the blank

résine: ajuster, façonner
 zircone non frittée: séparer, enlever des joints et séparer la zircone frittée du moule

resinas blandas o permanentemente blandas: formar y fresar dióxido de zirconio presinterizado: para el corte y la limpieza de los puntos de inserción hasta la separación de piezas



X



H/HP/PM	K424X 040	K424X 060	K425X 060	K429X 040	K429X 060	K426X 023	K432X 023	K433X 016	K433X 023
						*	*	*	*
L mm	8,0	11,0	14,0	13,0	13,0	15,0	14,5	7,5	12,0

Grobe schnittfreundige GQSR-Verzahnung/coarse power GQSR-cut
 denture grosse sécante GQSR/dentado grueso de alto rendimiento GQSR

Weichbleibende und weiche Kunststoffe: Ausarbeiten
 Zirkonoxid-Weißlinge: Trennen, Verputzen von Ansatzstellen und Herausstrennen von Zirkonoxid-Weißlinge aus dem Blank

non-hardening and soft acrylics: processing
 pre-sintered zirconia: separating, cleaning the point of attachment and removal of pre-sintered zirconia from the blank

résine molle: ajuster
 zircone non frittée: séparer, enlever des joints et séparer la zircone non frittée de la moule

resinas blandas o permanentemente blandas: formar y fresar dióxido de zirconio presinterizado: para el corte y la limpieza de los puntos de inserción hasta la separación de piezas



GQSR



H/HP/PM	K424GQSR 060	K425GQSR 060	K429GQSR 040	K432GQSR 023	K433GQSR 023
				*	*
L mm	11,0	14,0	13,0	14,5	12,0

* = Vollkeramikinstrumente
 full-ceramic instruments
 instrument céramique intégral
 instrumentos pura de cerámica

Nicht geeignet für Metalle!
 Not suitable for metals!
 Ne pas utiliser pour de métaux!
 No debe usar estas fresas para metales!

Zahntechnik



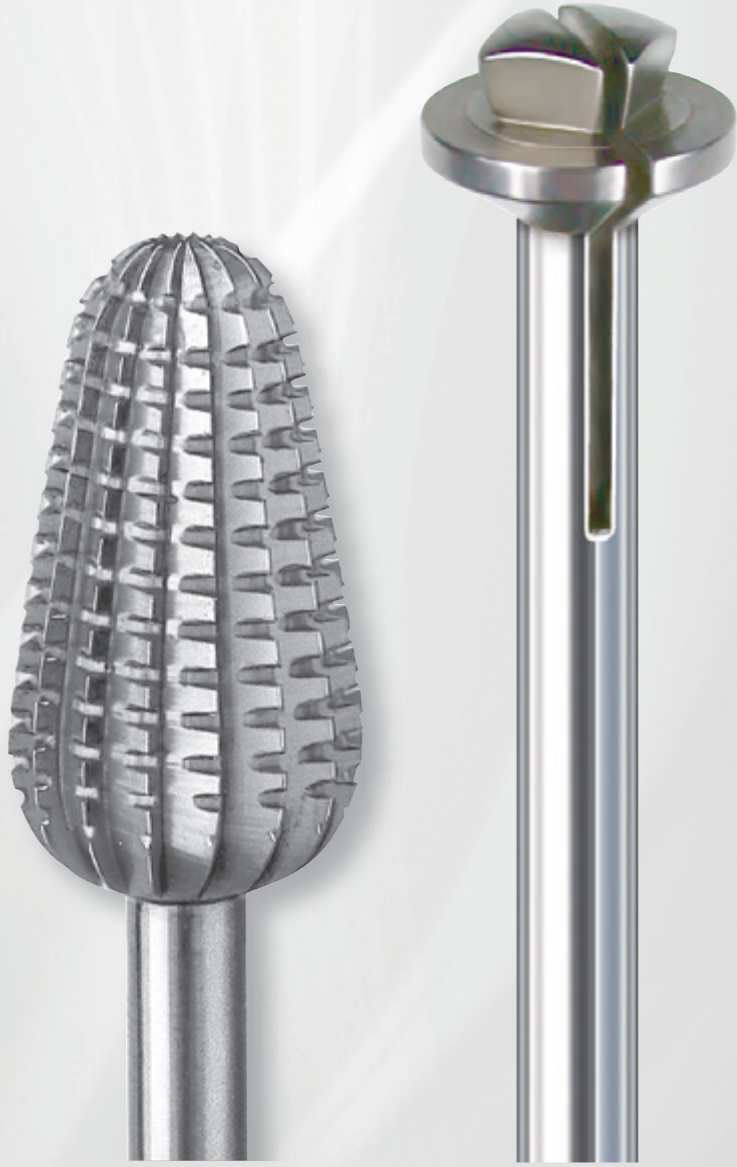



Dental Technology • Prothese Dentaire • Protesis Dental



Stahl

Steel • Acier • Acero

Anwendungsbeispiele Examples of application Exemples d'application Ejemplos de aplicaciones	130
Bohrer, Finierer Burs, finishing burs Fraises, Fraises à finir Fresas, Fresas de acabar	131+132
Fräser für Kunststoff und Gips Cutters for acrylic and plaster Fraises pour résine et plâtre Fresas para resina y yeso	133+134
Spezial-Instrumente Special instruments Instruments spéciaux Instrumentos especiales	135
Träger Mandrels Mandrins Mandriles	136+137

Einsatzgebiet used on domaine d'application uso en sector	Instrumentenbeispiel examples of instruments exempl. d'instruments ej. de los instrumentos	ISO-Ø	empfohlene Drehzahl min ⁻¹ recommended speed r.p.m. vitesse de rotation rec. velocidad recomendada
Kunststoff, Gips acrylics, plaster résine, plâtre acrílica, yeso	1 	005-023 025-037 040-050	20.000- 14.000 14.000- 9.000 9.000- 6.000
Kunststoff, Gips acrylics, plaster résine, plâtre acrílica, yeso	75 	045-050 060-080	20.000- 10.000 15.000- 5.000
Kunststoff acrylics résine acrílica	48 	008-018 021-040	20.000- 14.000 14.000- 8.000
Weichbleibende Kunststoffe soft relining materials résine molles resinas blandas	85 	050-080	8.000- 5.000
Spezialinstrumente special instruments instruments spéciaux instrumentos especiales	203 	005-023	5.000- 1.000
Metalle metals métaux metales	452S 	080-120	6.500- 4.500
Träger mandrels mandrins mandriles	303 	023-080	In Abhängigkeit vom mon- tierten Werkzeug depending on the instrument mounted on the mandrel en fonction de l'instrument monté sur le mandrin dependiente del instrumento colocado en el mandrin

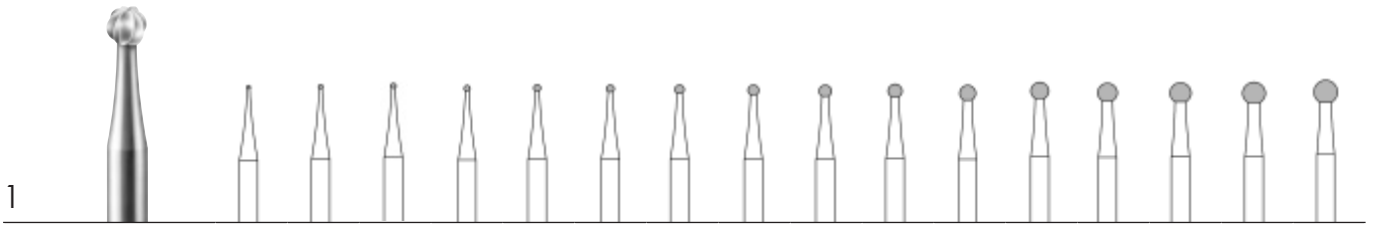

US-No	1/4	1/2	3/4	1	1 1/2	2	3	4	5	6	7	8	9	10	11	
H/HP/PM	005	006	007	008	009	010	012	014	016	018	021	023	025	027	029	031
ISO 310 104 001 001...																

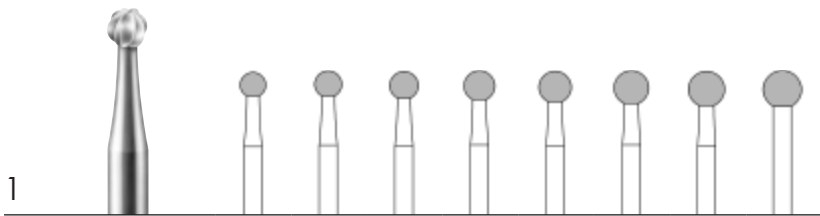

US-No							19	20
H/HP/PM	033	035	037	040	042	045	047	050
ISO 310 104 001 001...								

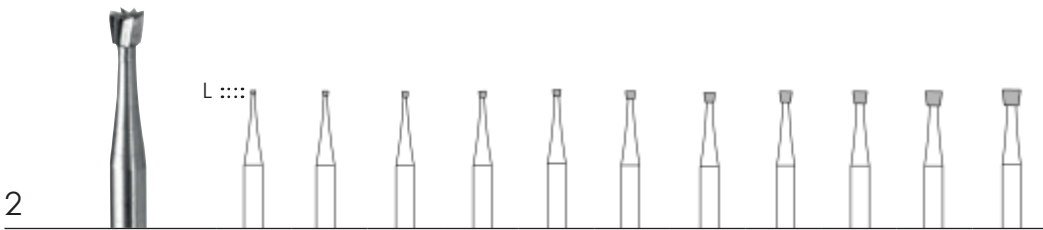

US-No	33 1/2		34	34 1/2	35	36	37	38	39	40	41
H/HP/PM	006	007	008	009	010	012	014	016	018	021	023
ISO 310 104 010 001...											
L mm	0,53	0,62	0,71	0,80	0,88	1,06	1,24	1,41	1,59	1,86	2,03

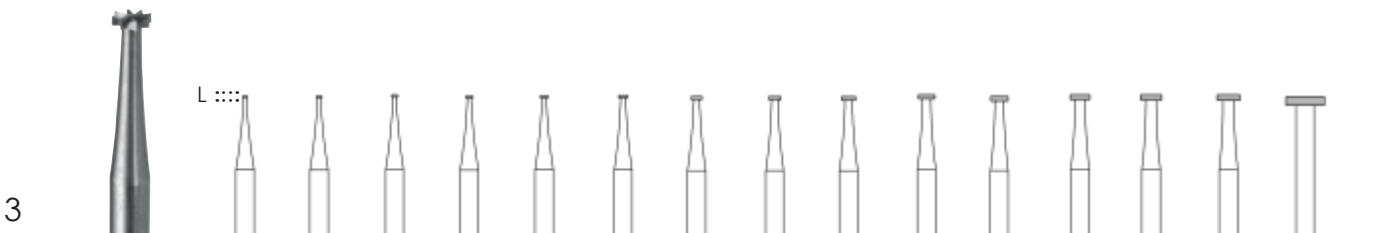

US-No	11 1/2		12		13	14	15	16		17	18				
H/HP/PM	006	007	008	009	010	012	014	016	018	021	023	025	027	029	050
ISO 310 104 040 001...															
L mm	0,21	0,23	0,25	0,27	0,30	0,33	0,36	0,40	0,45	0,53	0,58	0,63	0,68	0,73	1,16

36

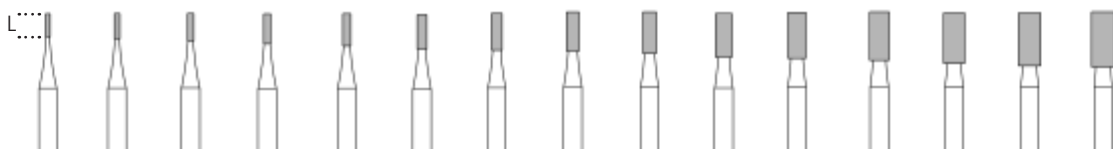

US-No	555		556		557	558	559	560	561	562	563	564			
H/HP/PM	006	007	008	009	010	012	014	016	018	021	023	025	027	029	031
ISO 310 104 107 002...															
L mm	3,0	3,3	3,6	3,9	4,2	4,5	4,8	5,1	5,4	5,7	6,0	6,3	6,6	6,9	7,2

38

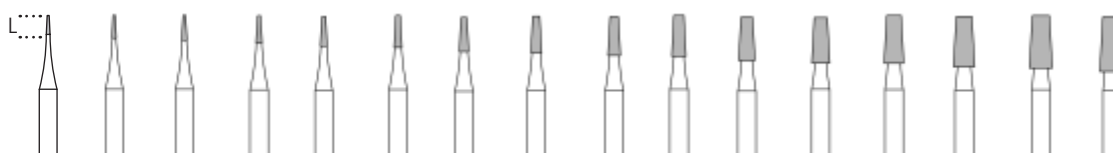

US-No		698		699		700	701		702		703	704	705		706	
H/HP/PM	005	006	007	008	009	010	012	014	016	018	021	023	025	027	029	031
ISO 310 104 168 002...																
L mm	2,5	3,0	3,3	3,6	3,9	4,2	4,5	4,8	5,1	5,4	5,7	6,0	6,3	6,6	6,9	7,2

Finierer/finishing burs
 Fraises à finir/fresas de acabar

41

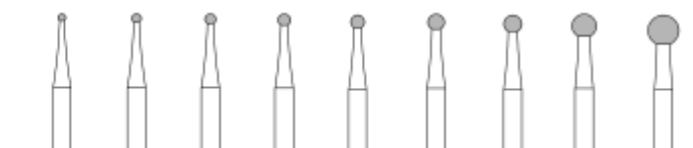

US-No	7002		7004	7005	7006		7008		
H/HP/PM	010	012	014	016	018	021	023	031	040
ISO 310 104 001 071...									

48

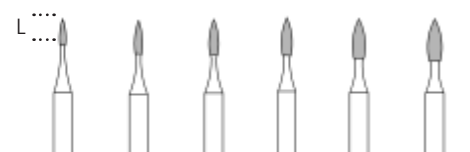

H/HP/PM	008	010	012	014	016	018
ISO 310 104 243 071...						
L mm	3,5	4,4	4,7	5,0	5,25	5,5

Stahl • Fräser für Kunststoff und Gips
 Steel • Cutters for acrylic and plaster
 Acier • Fraises pour résine et plâtre
 Acero • Fresas para resina y yeso

Zahntechnik
 Dental Technology
 Prothese Dentaire
 Protesis Dental

für Kunststoff und Gips/for acrylic and plaster/pour résine et plâtre/para resina y yeso

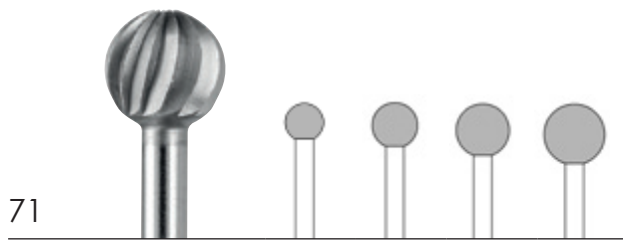

71



H/HP/PM ISO 310 104 001 171...	050	060	070	080

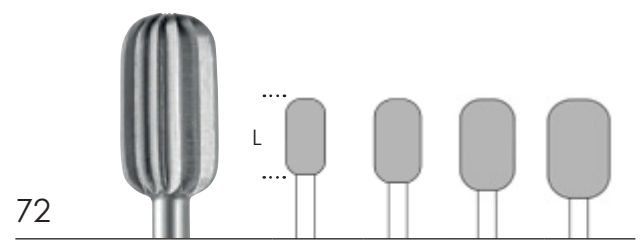

72



H/HP/PM ISO 310 104 155 171...	050	060	070	080
L mm	10,0	11,0	12,0	13,0

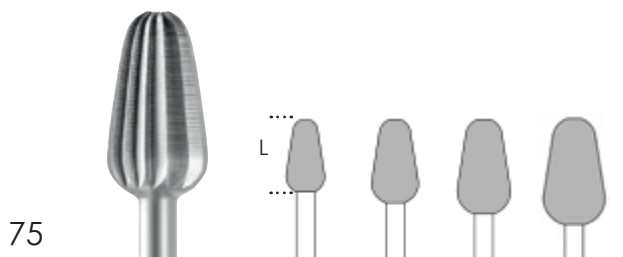

75



H/HP/PM ISO 310 104 260 171...	050	060	070	080
L mm	9,5	11,0	12,5	14,0

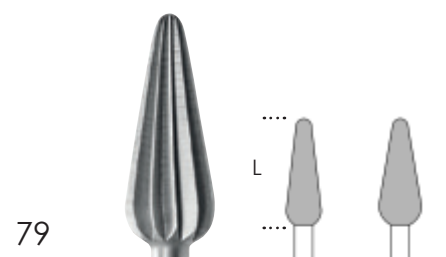

79



H/HP/PM ISO 310 104 266 171...	045	055
L mm	14,0	14,0

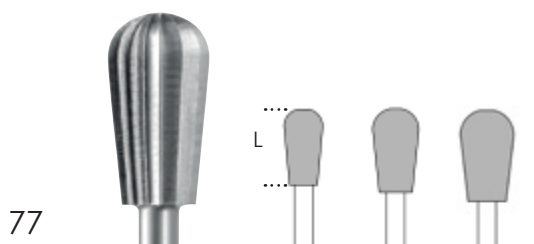

77



H/HP/PM ISO 310 104 237 171...	050	060	070
L mm	10,0	11,0	12,0



76



H/HP/PM ISO 310 104 254 171...	080
L mm	11,0

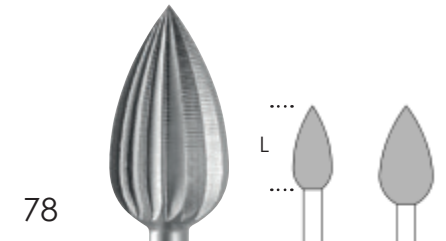

78



H/HP/PM ISO 310 104 257 171...	050	070
L mm	11,0	13,0



Stahl • Fräser für Kunststoff und Gips
 Steel • Cutters for acrylic and plaster
 Acier • Fraises pour résine et plâtre
 Acero • Fresas para resina y yeso

für weichbleibende Kunststoffe/for soft relining materials/pour resines molles/para resinas blandas

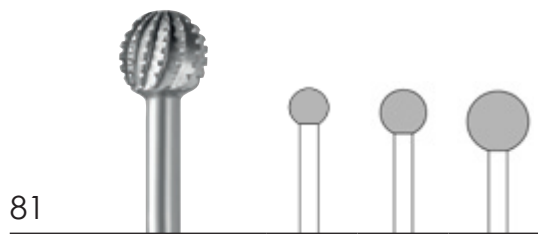

81



H/HP/PM	050	060	080
ISO 310 104 001 172...			
<input type="text"/>			

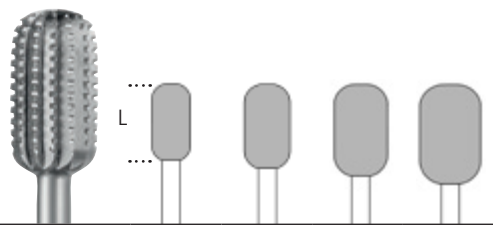

82



H/HP/PM	050	060	070	080
ISO 310 104 155 172...				
<input type="text"/>				
L mm	10,0	11,0	12,0	13,0

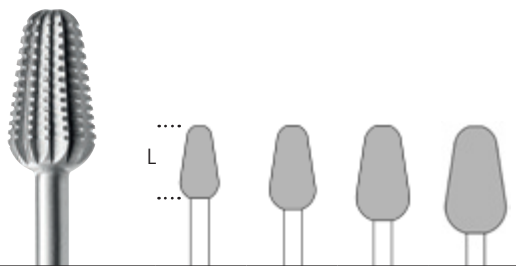

85



H/HP/PM	050	060	070	080
ISO 310 104 260 172...				
<input type="text"/>				
L mm	9,5	11,0	12,5	14,0

203

ISO 310 104 417 364...

H/HP/PM	005	006	007	008	009	010	011	012	013	014	015	016	017	018	019	020	021	022	023	
L mm	10,0	10,0	10,0	10,0	12,0	12,0	12,0	12,0	12,0	12,0	12,0	12,0	12,0	12,0	12,0	12,0	12,0	12,0	12,0	12,0

219

ISO 310 104 468 211...

H/HP/PM	023	027
L mm	12,0	12,0

Stauchrad
 ramwheel
 roue à refouler
 rueda de recalcar

Nietrad
 riveting wheel
 roue à river
 rueda de remachar

452S

ISO 310 104 100 383...

H/HP/PM	100
L mm	1,7

452RS*

ISO 330 104 100 381...

H/HP/PM	080	100	120
L mm	1,8	1,9	1,9

RS* = rostsicher Σ stainless Σ inoxyvable Σ inoxidable

TOP MANDREL

Scheibenträger
 disc mandrels
 porte-disque
 portadisco



303

	
H/HP/PM	050
ISO 300 104 603 391...	
	

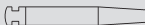
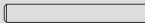

303RS*

		
US-No	303	
W/RA/CA	050	
ISO 330 204 603 391...		
		
H/HP/PM	050	
ISO 330 104 603 391...		
		

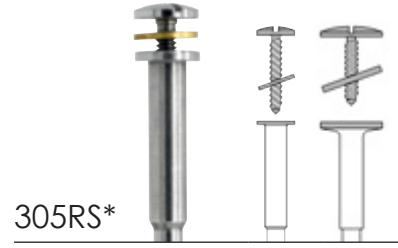

305RS*

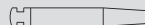
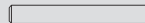
			
US-No	321		
W/RA/CA	050		
ISO 330 204 604 391...			
			
H/HP/PM	050	080	
ISO 330 104 604 391...			
			

Spezialträger für Politurwalzen
 special mandrel for polishing cylinders
 mandrin spécial pour cylindres de polissage
 mandril especial para cilindros de pulimento

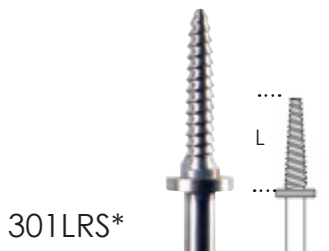

301LRS*

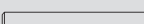
	
H/HP/PM	050
ISO 330 104 610 415...	
	
L mm	11,5

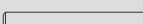

329

	
H/HP/PM	027
ISO 311 104 610 417...	
	
L mm	12,0

Spezialträger für Politur-Pins und Miniaturpinsel
 special mandrel for polishing pins and end brushes
 mandrin spécial pour pins de polissage et mini pinceau
 mandril especial para pins de pulimento y pinceles

Soft Disc Träger
 Soft Disc mandrel
 Soft Disc mandrin
 mandril „Soft Disc“

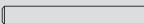

324RS*

	
H/HP/PM	030
ISO 330 104 612 432...	
	



312RS*

	
W/RA/CA	016
ISO 330 204 204 608	
	

RS* = rostsicher Σ stainless Σ inoxydable Σ inoxidable

Träger für Papierscheiben mit Metallzentrum
 mandrel for paper discs with metal centre
 mandrin pour disques papier avec centre métallique mandril
 para discos papel con centro metalico



313RS*



W/RA/CA ISO 330 204 615 421...	060
H/HP/PM ISO 330 104 615 421...	060

Papierstreifenträger
 sandpaper strip mandrel
 porte-bande papier
 portacinta papel

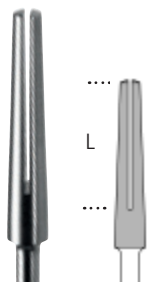

314RS*



H/HP/PM ISO 330 104 622 444...	040
L mm	17,0

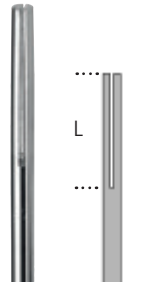

318RS*



H/HP/PM ISO 330 104 623 443...	023
L mm	15,0

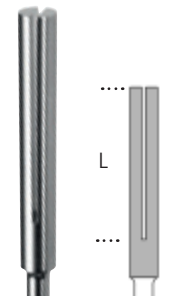

315RS*



H/HP/PM ISO 330 104 623 444...	035
L mm	20,0

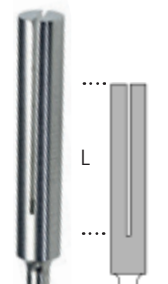

316RS*



H/HP/PM ISO 330 104 623 444...	045
L mm	20,0

RS* = rostsicher Σ stainless Σ inoxyvable Σ inoxidable

Zahntechnik

Dental Technology • Prothese Dentaire • Protesis Dental

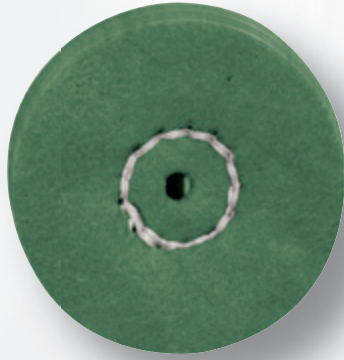

Polierer

Polishers • Polissoirs • Pulidores

Vorpolierer Pre-polishers Pré-polissoirs pour Pre-pulidores para	140
2-stufiges Poliersystem für Edelmetall-Legierungen und NEM 2-step polishing system for precious metal alloys and non-precious Système de polissage en 2 étapes pour alliages de métaux précieux et non précieux Sistema de pulimento en 2 etapas para aleaciones de metales preciosos et non-preciosos	141
2 in 1 Zirkon Weißlingspolierer Polisher for pre-sintered Polissoir pour zircone pré-fritté Pulidor para zirconia presinterizada	142
Dia-Disc	143
2-stufiges diamantdurchsetztes Poliersystem für Keramik/Silikatkeramik 2-step diamond interspersed polishing system for ceramics/silicate ceramics Système de polissage en 2 étapes imprégné de diamant pour la céramique/céramique silicatée Sistema de pulimento en 2 etapas impregnado de diamante para cerámica/cerámica de silicatos	144
2-stufiges diamantdurchsetztes Poliersystem für Zirkonoxid 2-step diamond interspersed polishing system for zirconia Système de polissage en 2 étapes imprégné de diamant pour l'oxyde de zirconium Sistema de pulimento en 2 etapas impregnado de diamante para óxido de circonio	145
3-stufiges Poliersystem für Kunststoff, SOFT WHEELS 3-step polishing system for acrylic, SOFT WHEELS Système de polissage en 3 étapes pour acrylique, SOFT WHEELS 3 etapas de pulimento para acrílico, SOFT WHEELS	146+147
Schwabbel, Polierpaste Polishing buffs, polishing paste Disques à polir, pâte à polir Discos de trapos, pasta de pulir	148
Bürsten Brushes Brosses Cepillos	149

**Vorpolitur alle
Werkstoffe, weiß**

 Siliziumkarbid (SiC), Silikon
 Korngröße grob
 Bindungshärte mittel

**pre-polishing for all
materials, white**

 silicon carbide (SiC), Silicone
 grit size coarse
 bond hardness medium

**pre-polishing pour tous
matériels, blanc**

 carbure de silicium (SiC),
 silicone
 taille de grain gros
 dureté de liaison moyen

**prepulimento para todos
los materiales, blanco**

 carburo de silicio (SiC),silicona
 tamaño de grano grueso
 dureza de ligazón media

H/HP/PM ISO 658 104 ...	9702G/145 372 533 145	9706G/055 243 523 055
L mm	2,5	15,0

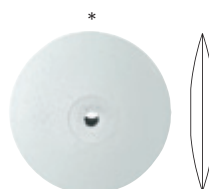
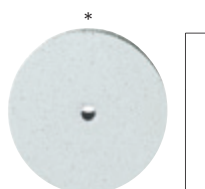

Unmontiert /unmounted / non-monté /sin montar ISO 658 900 ...	9602G/220 372 533 220	9603G/220 303 533 220
L mm	3,0	4,0

**Vorpolitur Modellguß-
legierungen, CrCo,
mocca**

 Siliziumkarbid (SiC), PUR
 Korngröße mittel
 Bindungshärte hart

**pre-polishing for model
casting, CrCo,
mocha**

 silicon carbide (SiC), PUR
 grit size medium
 bond hardness medium

**prépolissage pour
stellite, CrCo,
mocca**

 carbure de silicium (SiC), PUR
 taille de grain moyen
 dureté de liaison moyen

**prepulimento para alea-
ciones de colados, CrCo,
moca**

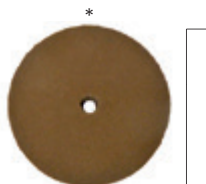
 carburo de silicio (SiC), PUR
 tamaño de grano medio
 dureza de ligazón media

*Besonders hohe Standzeit!
Very high endurance!
Durabilité prolongée!
Duración muy larga!*



Unmontiert /unmounted / non-monté /sin montar ISO 653 900	9660/220 372 524 220
L mm	3,0

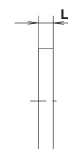

L = Arbeitsteillänge mm/working part length mm/longueur de la partie travaillante mm/longitud de la parte de fresado mm

* Träger siehe Seite 136/mandrels see page 136/mandrins voir page 136/mandriles vea página 136

2-stufiges Poliersystem für Edelmetall-Legierungen und NEM

2-step polishing system for precious and non-precious metal alloys

Système de polissage en 2 étapes pour alliages de métaux précieux et non précieux

Sistema de pulimento en 2 etapas para aleaciones de metales preciosos y non-preciosos

Vorpolitur, braun

Siliziumkarbid (SiC), PUR
Korngröße mittel
Bindungshärte mittel

pre-polishing, brown

silicon carbide (SiC), PUR
grit size medium
bond hardness medium

prépolissage, marron

carbure de silicium (SiC), PUR
taille de grain moyen
dureté de liaison moyen

prepulimento, marrón

carburo de silicio (SiC), PUR
tamaño de grano medio
dureza de ligazón media

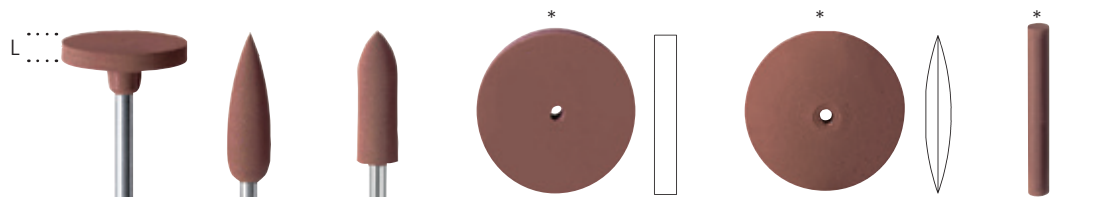

H/HP/PM ISO 653 104 ...	9702/145 042 513 145	9706/055 243 513 055	9704/050 292 513 050			
Unmontiert / unmounted / non-monté / sin montar ISO 653 ...				9602/220 900 372 513 220	9603/220 900 303 513 220	9605/030 000 114 513 030
L mm	2,0	18,0	16,0	3,0	4,0	23,0

Glanzpolitur, grün

Siliziumkarbid (SiC), PUR
Korngröße fein
Bindungshärte weich

high-lustre polishing, green

silicon carbide (SiC), PUR
grit size fine
bond hardness soft

polissage brillant, vert

carbure de silicium (SiC), PUR
taille de grain fin
dureté de liaison doux

pulimento de brillo, verde

carburo de silicio (SiC), PUR
tamaño de grano fino
dureza de ligazón blanda

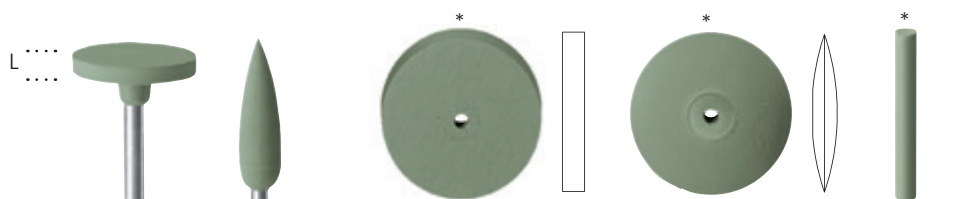

H/HP/PM ISO 653 104 ...	9712/145 042 504 145	9716/055 243 504 055			
Unmontiert / unmounted / non-monté / sin montar ISO 653 ...			9612/220 900 372 504 220	9613/220 900 303 504 220	9615/030 000 114 504 030
L mm	2,0	18,0	3,0	4,0	23,0

L = Arbeitsteillänge mm/working part length mm/longueur de la partie travaillante mm/longitud de la parte de fresado mm

* Träger siehe Seite 136/mandrels see page 136/mandrins voir page 136/mandriles vea página 136

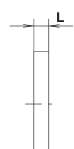



Polierer
Polishers
Polissoirs
Pulidores

2 in 1

Zirkon Weißlingspolierer
(mittel/fein)

Politur der Ansatzstellen,
ausdünnen der Ränder
(grau/mittel)

Feinpolitur
(weiß/fein)

2 in 1

polisher for pre-sintered
zirconia (medium/fine)

polishing the attachment
points, thinning the edges
(grey/medium)

fine polishing
(white/fine)

2 in 1

polissoir pour zircone
pré-fritté (moyen/fin)

polissage des points
d'attache, affinage des
bords (gris/moyen)

polissage fin
(blanc/fin)

2 in 1

pulidor para zirconia
presinterizada (medio/fino)

pulido de los puntos de
fijación. Afinamiento de
bordes (gris/medio)

pulido fino
(blanco/fino)



H/HP/PM	9800
L mm	055

DIA DISC



Hochflexible, diamantdurchsetzte Kunststoffscheiben zum Vorschleifen oder Feinschleifen von Keramik und Komposit Diamant, Kunststoffbindung montiert

a high flexible interspersed diamond synthetic disc for pre-grinding and moulding ceramics and composites diamond, acrylic bond mounted

disque synthétique imprégné de diamant, extrêmement flexible, pour le prépolissage et modelage de la céramique et des composites, diamant, liaison résine monté

un disco sintético impregnado de diamante de extrema flexibilidad para prepulimento y correcciones de cerámica y composites, diamante, ligazón acrílico montado

Vorschleifen,
dunkelgrün

Korngröße grob

pre-grinding,
dark green

grit size coarse

prépolissage,
vert foncé

taille de grain gros

prepulimento,
verde oscuro

tamaño de grano grueso

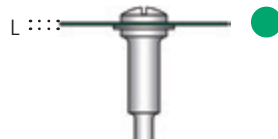

H/HP/PM ISO 803 104 ...	9690G/220 354 534 220
L mm	0,3

Feinschleifen,
ziegel

Korngröße mittel

fine-grinding,
brick coloured

grit size medium

polissage fin,
brique

taille de grain moyen

pulimento fino,
ladrillo

tamaño de grano medio

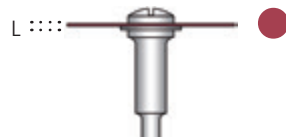

H/HP/PM ISO 803 104 ...	9690M/220 354 524 220
L mm	0,25



diamantdurchsetzt/diamond interspersed/imprégné de diamant/impregnado de diamante



2-stufiges diamantdurchsetztes Poliersystem für Keramik/Silikatkeramik
2-step diamond interspersed polishing system for ceramics/silicate ceramics
Système de polissage en 2 étapes imprégné de diamant pour la céramique/céramique silicatée
Sistema de pulimento en 2 etapas impregnado de diamante para cerámica/cerámica de silicatos

Vorpolitur, rot gelb

Diamant, PUR
Korngröße mittel
Bindungshärte mittel

pre-polishing, red yellow

diamond, PUR
grit size medium
bond hardness medium

prépolissage, rouge jaune

diamant, PUR
taille de grain moyen
dureté de liaison moyen

prepulido, rojo amarillo

diamante, PUR
tamaño de grano medio
goma de dureza media

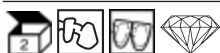

H/HP/PM ISO 803 104 ...	9952/110 372 522 110	9954/040 243 522 040	9953/260 303 522 260	9955/170 543 522 170	
Unmontiert / unmounted / non-monté / sin montar ISO 803 900					9956/170 372 522 170
L mm	2,0	13,0	2,0	1,6	2,5

Hochglanzpolitur, grün gelb

Diamant, PUR
Korngröße fein
Bindungshärte mittel

high shine-polishing,, green yellow

diamond, PUR
grit size fine
bond hardness medium

polissage haute brillance, vert jaune

diamant, PUR
taille de grain fin
dureté de liaison moyen

pulido de alto brillo, verde amarillo

diamante, PUR
tamaño de grano fino
goma de dureza media



H/HP/PM ISO 803 104 ...	9962/110 372 512 110	9964/040 243 512 040	9963/260 303 512 260	9965/170 543 512 170	
Unmontiert / unmounted / non-monté / sin montar ISO 803 900					9966/170 372 512 170
L mm	2,0	13,0	2,0	1,6	2,5



diamantdurchsetzt/diamond interspersed/imprégné de diamant/impregnado de diamante



2-stufiges diamantdurchsetztes Poliersystem für Zirkonoxid
2-step diamond interspersed polishing system for zirconia
Système de polissage en 2 étapes imprégné de diamant pour l'oxyde de zirconium
Sistema de pulimento en 2 etapas impregnado de diamante para óxido de circonio

Vorpolitur, türkis gelb

Diamant, PUR
Korngröße mittel
Bindungshärte hart

pre-polishing,
turquoise yellow

diamond, PUR
grit size medium
bond hardness hard

prépolissage,
turquoise jaune

diamant, PUR
taille de grain moyen
dureté de liaison dure

prepulido,
turquesa amarillo

diamante, PUR
tamaño de grano media
goma de dureza dura



H/HP/PM ISO 803 104 ...	9852/110 372 524 110	9854/040 243 524 040	9853/260 303 524 260	9855/170 543 524 170	
Unmontiert / unmounted / non-monté / sin montar ISO 803 900					9856/170 372 524 170
L mm	2,0	13,0	2,0	1,6	2,5

Hochglanzpolitur,
rosa gelb

Diamant, PUR
Korngröße fein
Bindungshärte hart

high shine-polishing,
pink yellow

diamond, PUR
size fine
bond hardness hard

polissage haute
brillance, rose jaune

diamant, PUR
taille de grain fin
dureté de liaison dure

pulido de alto brillo,
rosa amarillo

diamante, PUR
tamaño de grano fino
goma de dureza dura



H/HP/PM ISO 803 104 ...	9862/110 372 514 110	9864/040 243 514 040	9863/260 303 514 260	9865/170 543 514 170	
Unmontiert / unmounted / non-monté / sin montar ISO 803 900					9866/170 372 514 170
L mm	2,0	13,0	2,0	1,6	2,5



diamantdurchsetzt/diamond interspersed/imprégné de diamant/impregnado de diamante

3-stufiges Poliersystem für Kunststoff
3-step polishing system for acrylic
Système de polissage en 3 étapes pour acrylique
3 etapas de pulimento para acrílico

Vorpolitur, grün

Siliziumkarbid (SiC), Silikon
Korngröße grob
Bindungshärte mittel

pre-polishing, green

silicon carbide (SiC), silicone
grit size coarse
bond hardness medium

prépolissage, vert

carbure de silicium (SiC), silicone
taille de grain gros
dureté de liaison moyenne

prepulido, verde

carburo de silicio (SiC), silicona
tamaño de grano grueso
dureza de la ligazón media



H/HP/PM ISO 658 104 ...	9626G/055 243 533 055	9626G/100 300 533 100	9626G/120 257 533 120	9628G/065 274 533 065	9628G/100 275 533 100
L mm	16,0	20,0	22,0	17,0	24,0

Glanzpolitur, anthrazit

Siliziumkarbid (SiC), Silikon
Korngröße mittel
Bindungshärte mittel

shine-polishing,,
anthrazite

silicon carbide (SiC), silicone
grit size medium
bond hardness medium

polissage brillant,
anthrazite

carbure de silicium (SiC), silicone
taille de grain moyen
dureté de liaison moyenne

pulido brillante,
antracita

carburo de silicio (SiC), silicona
tamaño de grano medio
dureza de la ligazón media



H/HP/PM ISO 658 104 ...	9626/055 243 523 055	9626/100 300 523 100	9626/120 257 523 120	9628/065 274 523 065	9628/100 275 523 100
L mm	16,0	20,0	22,0	17,0	24,0

Hochglanzpolitur,
khaki

Siliziumkarbid (SiC),
Silikon, Korngröße fein
Bindungshärte mittel

high shine-polishing,
khaki

silicon carbide (SiC),
Silicone, grit size fine
bond hardness medium

polissage haute
brillance, kaki

carbure de silicium (SiC),
silicone, taille de grain fin
dureté de liaison moyenne

pulido de alto brillo,
caqui

carburo de silicio (SiC), silicona
tamaño de grano fino
dureza de la ligazón media



H/HP/PM ISO 658 104 ...	9622/055 243 513 055	9622/100 300 513 100	9622/120 257 513 100	9624/065 274 513 065	9624/100 275 513 100
L mm	16,0	20,0	22,0	17,0	24,0

SOFT WHEELS, imprägnierte Baumwollschwabbel für Metalle und Kunststoffe (Einsatz ohne Polierpaste)

SOFT WHEELS, impregnated buffs for metals and acrylics(application without polishing paste)

SOFT WHEELS, meulettes coton imprégnées pour métaux et acrylique(utilisation sans pâte à polir)

SOFT WHEELS, discos de algodón impregnados para pulir metales y acrílico(sin uso de pasta para pulir)

Vorpolitur, grün

Edelkorund (Al₂O₃)
Korngröße mittel

prépolissage,vert

corindon affiné (Al₂O₃)
taille de grain moyen

Glanzpolitur, pink

Edelkorund (Al₂O₃)
Korngröße extra fein

polissage brillant, rose

corindon affiné (Al₂O₃)
taille de grain extra fin

pre-polishing, green

high-grade corundum (Al₂O₃)
grit size medium

prepulido, verde

corindon fino (Al₂O₃)
tamaño de grano medio

shine-polishing, pink

high-grade corundum (Al₂O₃)
grit size extra fine

pulido brillante, fucsia

corindon fino (Al₂O₃)
tamaño de grano extra fino

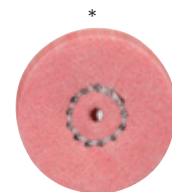
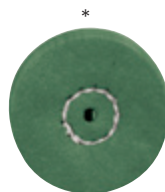

Unmontiert / unmounted / non-monté / sin montar ISO 019 900 ...	9544M/220 372 511 220
L mm	3,0



Unmontiert / unmounted / non-monté / sin montar ISO 019 900 ...	9544F/220 372 501 220
L mm	3,0

* Träger siehe Seite 136/mandrels see page 136/mandrins voir page 136/mandriles vea página 136



Schwabbel
Polishing buffs
Disques à polir
Discos de trapos

für Hochglanzpolitur mit
Diamantpaste

Cambric, feiner Nesselstoff

pour le polissage
spéculaire avec la pâte
de diamants

cambrai, mousseline

for high-lustre polishing with
diamond paste

cambric, fine nettle cloth

para el pulimento de alto
brillo con pastas
de diamante

cambrayón, fino

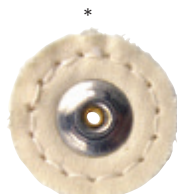

für Hochglanzpolitur
nach dem Pasteneinsatz

Wildleder

pour le polissage
spéculaire après
l'utilisation de la pâte

suède

for high-lustre polishing
after the use of paste

suede

para el pulimento de
alto brillo tras la
utilización de pastas

gamuza



Unmontiert/unmounted/
non-monté/sin montar

ISO

9641/220

050 900 373 000 220



Unmontiert/unmounted/
non-monté/sin montar

ISO

9642/220

040 900 373 000 220

Bohrung Ø 1,7 mm/Ø of centre hole 1,7 mm/alésage Ø 1,7 mm/perforación Ø 1,7 mm

für abschließende Hoch-
glanzpolitur nach dem
Pasteneinsatz

Baumwolle
cotton
coton
algodón

for the final high-lustre poli-
shing after the use of paste



pour le polissage spéculaire
de finition après l'utilisation
de la pâte

Microfaser
microfiber
microfibre
micro fibra

para el pulimento de alto brillo
de acabado tras la utilización
de pastas



Montiert/mounted
monté/montado



Unmontiert/unmounted/
non-monté/sin montar

ISO

9643/220

050 900 373 000 220



H/HP/PM

9644/250

Bohrung Ø 1,7 mm/Ø of centre hole 1,7 mm/
alésage Ø 1,7 mm/perforación Ø 1,7 mm

* Träger siehe Seite 136/mandrels see page 136/mandrins voir page 136/mandriles vea página 136

Polierpaste

Diamant (3µ), 5ml
Hochglanz für Metalle,
Keramik und Komposit
(Sparsame Anwendung)

polishing paste

Diamond (3µ), 5ml
high-lustre for metals,
ceramics and composites
(economical application)

pâte à polir

Diamant (3µ), 5ml
brillant pour métaux,
céramiques et composites
(application économique)

pasta de pulir

Diamante (3µ), 5ml
alto brillo para metales,
cerámica y composites
(utilización económica)

9646



für die Politur mit
Paste

for the polishing with
paste

pour le polissage
avec la pâte

para el pulimento
con pasta

Chungking, harte Borsten
chungking, hard bristles
chungking, durs
chungking, duras



Pferdehaar, harte Borsten
horsehair, hard bristles
poils de cheval, durs
cerdas de caballo, duras



Unmontiert / unmounted /
non-monté / sin montar
ISO

9636/190
100 900 543 000 190



H/HP/PM
ISO

9736/140
100 104 543 000 140

Bohrung Ø 1,7 mm/Ø of centre hole 1,7 mm/
alésage Ø 1,7 mm/perforación Ø 1,7 mm

Ziegenhaar, weiche Borsten
goat hair, soft bristles
poils de chèvre, doux
cerdas de cabra, blandas



Unmontiert / unmounted /
non-monté / sin montar
ISO

9638/190
090 900 543 000 190

Bohrung Ø 1,7 mm/Ø of centre hole 1,7 mm/
alésage Ø 1,7 mm/perforación Ø 1,7 mm

Ziegenhaar, weiche Borsten
goat hair, soft bristles
poils de chèvre, doux
cerdas de cabra, blandas



H/HP/PM
ISO

9738/140
090 104 543 000 140

9738/220
090 104 543 000 220

* Träger siehe Seite 136/mandrels see page 136/mandrins voir page 136/mandriles vea página 136

Zahntechnik

Dental Technology • Prothese Dentaire • Protesis Dental



Schleifkörper

Abrasives • Abrasifs • Abrasivos

Schleifkörper für Keramik, Kunststoffe, CERA-PLUS Schleifkörper
und Metall-Legierungen

Abrasives for ceramic, acrylics, CERA-PLUS abrasives
et metal alloys

Abrasifs pour céramique, acrylique, Abrasifs CERA-PLUS
et alliages métalliques

Abrasivos para cerámica, acrílico, Abrasivos CERA-PLUS
y aleaciones metálicas

152+153

ALOX Schleifkörper, Schleifkörper für mittelharte Metall-Legierungen
und Chrom-Kobalt

ALOX abrasives, Abrasives for medium hard metal alloys
and chrome-cobalt

Abrasifs ALOX, Abrasifs pour alliages métalliques moyen-durs
et chrome-cobalt

Abrasivos ALOX, Abrasivos para aleaciones metálicas media duras
y cromo-cobalto

154+155

Schleifräder und Trennscheiben

Abrasive wheels and Separating discs

Meules abrasives et Disques à séparer

Ruedas abrasivas y Discos para separar

156-161

für Keramik/
Silikatkeramik und
Zirkonoxid

Diamant, grau grün
synthetisch gebunden, ohne
Wasserkühlung verwendbar
Korngröße grob
Bindungshärte hart
Formschleifen

for ceramics/silicate
ceramics and zirconia

diamond, grey green
synthetic bond, to be used
without water cooling
grit size coarse
bond hardness hard moulding

pour la céramique/la
céramique silicatée et
l'oxyde de zirconie

diamant, gris vert
liaison synthétique utilisable
sans refroidissement par eau
taille de grain gros
dureté de liaison dur
meulage façonné

para cerámica/cerámica
de silicatos y dióxido
de circonio

diamante, gris verde
ligar sintética, para el uso sin
enfriamiento con agua
tamaño de grano grueso
dureza de la ligazón dura
rectificado

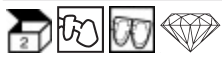

diamantdurchsetzt
diamond interspersed
imprégné de diamant
impregnado de diamante

H/HP/PM ISO 805 104 ...	D712/120 372 534 120	D733/040 173 534 040	D732/050 107 534 050
L mm	2,0	10,0	13,0

Diamant, rosa
synthetisch gebunden, ohne
Wasserkühlung verwendbar
Korngröße mittel
Bindungshärte hart
Formschleifen

diamond, pink
synthetic bond, to be used
without water cooling
grit size medium
bond hardness hard moulding

diamant, rose
liaison synthétique utilisable
sans refroidissement par eau
taille de grain moyen
dureté de liaison dur
meulage façonné

diamante, rosa
ligar sintética, para el uso sin
enfriamiento con agua
tamaño de grano medio
dureza de la ligazón dura
rectificado

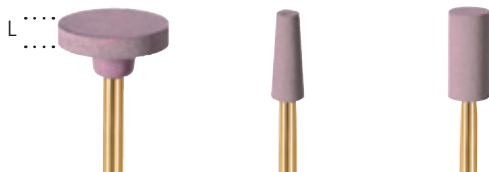

diamantdurchsetzt
diamond interspersed
imprégné de diamant
impregnado de diamante

H/HP/PM ISO 805 104	D702/120 372 524 120	D723/040 173 524 040	D722/050 107 524 050
L mm	2,0	10,0	13,0

CERA-PLUS Schleifkörper/CERA-PLUS abrasives/Abrasifs CERA-PLUS/Abrasivos CERA-PLUS

für Keramik

Siliziumkarbid
Schleifkörper (SiC), grün
Keramische Bindung
Korngröße fein
Bindungshärte mittel

for ceramics

silicon carbide abrasives
(SiC), green
ceramic bond
grit size fine
bonding hardness medium

pour céramique

abrasifs en carbure
de silicium (SiC), vert
liaison céramique
taille de grain fin
dureté de liaison moyenne

para cerámica

abrasivos de carburo
de silicio (SiC), verde
ligazón cerámica
tamaño de grano fino
dureza de la ligazón media



H/HP/PM ISO 655 104 ...	CP613/065 014 512 065	CP649R/025 197 512 025	CP652R/033 199 512 033	CP671/050 260 512 050	CP732/050 107 512 050	CP728/170 023 512 170
L mm	3,0	6,0	10,5	10,0	12,0	7,0

für Keramik, Kunststoffe,
 Metall-Legierungen

for ceramic, acrylics,
 metal alloys

pour céramique, acrylique,
 alliages métalliques

para cerámica, acrílico,
 aleaciones metálicas

Siliziumkarbid
 Schleifkörper (SiC), grün
 Keramische Bindung
 Korngröße mittel
 Bindungshärte mittel

silicon carbide
 abrasives (SiC), green
 ceramic bond
 Grit size medium
 bonding hardness medium

abrasifs en carbure
 de silicium (SiC), vert
 liaison céramique
 taille de grain moyenne
 dureté de liaison moyenne

abrasivos de carburo
 de silicio (SiC), verde
 ligazón cerámica
 tamaño de grano medio
 dureza de la ligazón media



H/HP/PM ISO 655 104 ...	601/030 001 523 030	602/040 001 523 040	613/065 014 523 065	622/060 042 523 060	628/060 069 523 060	632/065 304 523 065	633/085 304 523 085
L mm	-	-	3,0	3,4	4,4	2,8	3,8



H/HP/PM ISO 655 104 ...	637/025 110 523 025	639/035 110 523 035	649/025 171 523 025	661/030 243 523 030	662/035 243 523 035	665/065 273 523 065
L mm	6,0	6,0	6,0	6,5	7,5	13,0



H/HP/PM ISO 655 104 ...	671/050 260 523 050	743/135 254 523 135	744/110 273 523 110	731/065 107 523 065	732/050 107 523 050	733/035 168 523 035	734/090 316 523 090
L mm	10,0	18,0	17,0	13,0	12,0	10,5	3,9

ALOX Schleifkörper/ALOX abrasives/Abrasifs ALOX/Abrasivos ALOX

für edelmetallreduzierte
und edelmetallfreie
Metalle

Edelkorund Schleifkörper
(Al₂O₃), blau
Keramische Bindung
Korngröße mittel
Bindungshärte mittel

for semi-precious
and non-precious metals

high-grade corundum
abrasives (Al₂O₃), blue
ceramic bond
grit size medium
bonding hardness medium

pour alliages
semi-précieux et
non-précieux

abrasifs en corindon
affiné (Al₂O₃), bleu
liaison céramique
taille de grain moyen
dureté de liaison moyenne

para aleaciones
semi-preciosas y
no-preciosas

abrasivos de corindon fino
(Al₂O₃), azul
ligazón cerámica
tamaño de grano medio
dureza de la ligazón media



H/HP/PM ISO 635 104 ...	B601/030 001 523 030	B649R/025 197 523 025	B652R/033 199 523 033	B671/050 260 523 050	B732/050 107 523 050
L mm	-	6,0	10,5	10,0	12,0

für mittelharte Metall-
Legierungen

Edelkorund Schleifkörper
(Al₂O₃), rosa
Keramische Bindung
Korngröße mittel
Bindungshärte mittel

for medium hard
metal alloys

high-grade corundum
abrasives (Al₂O₃), pink
ceramic bond
grit size medium
bonding hardness medium

pour alliages métalliques
moyen-durs

abrasifs en corindon
affiné (Al₂O₃), rose
liaison céramique
taille de grain moyen
dureté de liaison moyenne

para aleaciones
metálicas media duras

abrasivos de corindon
fino (Al₂O₃), rosa
ligazón cerámica
tamaño de grano medio
dureza de la ligazón media



H/HP/PM ISO 625 104 ...	601/030 001 523 030	602/040 001 523 040	603/050 012 523 050	609/060 012 512 060	613/065 014 523 065	619/050 045 230 050	620/050 043 523 050	623/060 043 523 060	624/060 109 523 060	627/060 068 523 060
L mm	-	-	-	6,5	3,0	2,9	3,0	3,0	5,0	2,9



H/HP/PM ISO 625 104 ...	632/065 304 523 065	633/085 304 523 085	636/025 109 523 025	637/025 110 523 025	638/030 110 523 030	639/035 110 523 035	640/050 110 523 050	646/018 169 523 018	648/020 171 523 020	649/025 171 523 025
L mm	2,8	3,9	4,0	6,0	6,0	6,0	6,0	3,0	6,0	6,0



H/HP/PM ISO 625 104 ...	650/028 171 523 028	651/033 171 523 033	652/033 173 523 033	656/040 254 523 040	657/050 254 523 050	658/065 254 523 065	661/030 243 523 030	662/035 243 523 035	663/050 243 523 050	665/065 273 523 065	666/033 257 523 033
L mm	6,0	6,0	10,5	4,8	5,5	8,8	6,5	7,5	9,5	13,0	6,0



H/HP/PM ISO 625 104 ...	667/040 257 523 040	671/050 260 523 050	677/050 237 523 050	682/060 280 523 060	701/080 041 523 080	703/130 041 523 130	711/080 042 523 080	712/095 042 523 095	716/160 372 523 160
L mm	7,0	10,0	9,5	6,0	3,6	3,3	5,1	5,1	5,0



H/HP/PM ISO 625 104 ...	721/125 304 523 125	722/160 304 523 160	743/135 254 523 135	744/110 273 523 110	749/130 175 523 130	755/060 001 523 060	760/065 112 523 065
L mm	4,2	4,6	18,0	17,0	15,0	-	10,0

für Chrom-Kobalt

Edelkorund Schleifkörper
 (Al₂O₃), rosa
 Keramische Bindung
 Korngröße mittel
 Bindungshärte mittel

for chrome-cobalt

high-grade corundum
 abrasives (Al₂O₃), pink
 ceramic bond
 grit size medium
 bonding hardness medium

pour chrome-cobalt

abrasifs en corindon
 affiné (Al₂O₃), rose
 liaison céramique
 taille de grain moyen
 dureté de liaison moyenne

para cromo-cobalto

abrasivos de corindon
 fino (Al₂O₃), rosa
 ligazón cerámica
 tamaño de grano medio
 dureza de la ligazón media



H/HP/PM ISO 625 104 ...	731/065 107 523 065	732/050 107 523 050	733/035 168 523 035
L mm	13,0	12,0	10,5

für kühles, trockenes
Schleifen von Keramik
und Metall-Legierungen

for heatless and dry
grinding of ceramics
and metal alloys

pour le meulage froid
et sec de céramique et
alliages métalliques

esmerilar frío y seco
cerámica y aleaciones
metálicas

Siliziumkarbid Schleifräder (SiC)
Magnesitbindung
Unmontiert
Bohrung Ø 1,8 mm
Stärke 2,0/3,0/4,5 mm
Korngröße mittel
Bindungshärte weich
Trocken schleifen, nicht
desinfizieren oder sterilisieren;
trocken lagern

silicon carbide abrasive
wheels (SiC)
magnesite bond
unmounted
Ø of centre hole 1,8 mm
thickness 2,0/3,0/4,5 mm
grit size medium
bonding hardness soft
dry grinding, no disinfection,
no sterilization; dry storage

meules abrasives en carbure
de silicium (SiC)
liaison magnésite
non-monté
alésage Ø 1,8 mm
épaisseur 2,0/3,0/4,5 mm
taille de grain moyen
dureté de liaison doux
meuler au sec, ni désinfecter,
ni stériliser; stocker au sec

ruedas abrasivas de
carburo de silicio (SiC)
ligazón magnesita
sin montar
agujero Ø 1,8 mm
espesor 2,0/3,0/4,5 mm
tamaño de grano medio
dureza de la ligazón blanda
esmerilar en seco, ni desinfectar,
ni esterilizar; almacenar en seco



ISO 654 900 ...	761/130 371 522 130	762/130 372 522 130	766/160 371 522 160	767/160 372 522 160
L mm	2,0	3,0	2,0	3,0



ISO 654 900 ...	771/190 371 522 190	772/190 372 522 190	773/190 373 522 190
L mm	2,0	3,0	4,5

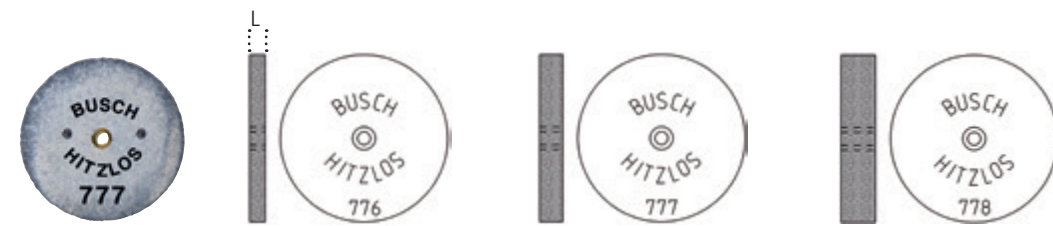

ISO 654 900 ...	776/220 371 522 220	777/220 372 522 220	778/220 373 522 220
L mm	2,0	3,0	4,5



ISO 654 900 ...	782/250 372 522 250	783/250 373 522 250
L mm	3,0	4,5

Träger siehe Seite 136/mandrels see page 136/
mandrins voir page 136/mandriles vea página 136

SILENT Schleifräder
 SILENT abrasive wheels
 SILENT meules abrasives
 SILENT ruedas abrasivas

Zahntechnik
 Dental Technology
 Prothese Dentaire
 Protésis Dental

für feinstes Schleifen
 von Keramik und
 Metall-Legierungen

Siliziumkarbid
 Schleifräder (SiC)
 Magnesitbindung
 Unmontiert
 Bohrung Ø 1,8 mm
 Stärke 2,0/3,0/4,5 mm
 Korngröße fein
 Bindungshärte weich
 Trocken schleifen, nicht
 desinfizieren oder sterilisieren;
 trocken lagern

for finest grinding
 of ceramics and
 metal alloys

silicon carbide abrasive
 wheels (SiC)
 magnesite bond
 unmounted
 Ø of centre hole 1,8 mm
 thickness 2,0/3,0/4,5 mm
 grit size fine
 bonding hardness soft
 dry grinding, no disinfection,
 no sterilization; dry storage

pour le meulage très fin
 de céramique et alliages
 métalliques

meules abrasives en
 carbure de silicium (SiC)
 liaison magnésite
 non-monté
 alésage Ø 1,8 mm
 épaisseur 2,0/3,0/4,5 mm
 Taille de grain fin
 dureté de liaison doux
 meuler au sec, ni désinfecter,
 ni stériliser; stocker au sec

esmerilar de forma fina
 la cerámica y aleaciones
 metálicas

ruedas abrasivas de
 carburo de silicio (SiC)
 ligazón magnesita
 sin montar
 agujero Ø 1,8 mm
 espesor 2,0/3,0/4,5 mm
 tamaño de grano fino
 dureza de la ligazón blanda
 esmerilar en seco, ni
 desinfectar, ni esterilizar;
 almacenar en seco

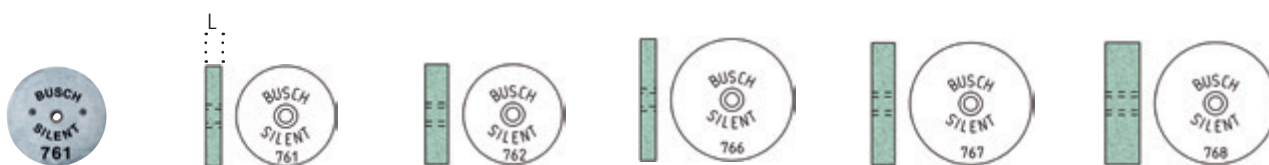

ISO 654 900 ...	761/130 371 512 130	762/130 372 512 130	766/160 371 512 160	767/160 372 512 160	768/160 373 512 160
L mm	2,0	3,0	2,0	3,0	4,5



ISO 654 900 ...	771/190 371 512 190	772/190 372 512 190	773/190 373 512 190
L mm	2,0	3,0	4,5

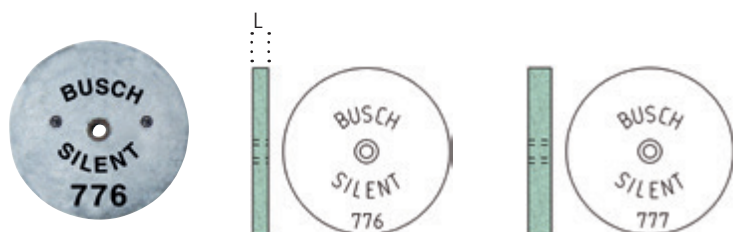

ISO 654 900 ...	776/220 371 512 220	777/220 372 512 220
L mm	2,0	3,0



für Kunststoffe und Metall-Legierungen

Siliziumkarbid Schleifräder (SiC), grün
Keramische Bindung
Unmontiert
Bohrung Ø 6,5 mm
Stärke 6,5 mm
Korngröße mittel, grob
Bindungshärte mittel

for acrylics and metal alloys

silicon carbide abrasive wheels (SiC), green
ceramic bond unmounted
Ø of centre hole 6,5 mm
thickness 6,5 mm
grit size medium, coarse
bonding hardness medium

pour résines et alliages métalliques

meules abrasives en carbure de silicium (SiC), vert
liaison céramique non-monté
alésage Ø 6,5 mm
épaisseur 6,5 mm
taille de grain moyen, gros dureté de liaison moyenne

para acrílico y aleaciones metálicas

ruedas abrasivos de carburo de silicio (SiC), verde
ligazón cerámica sin montar
agujero Ø 6,5 mm
espesor 6,5 mm
tamaño de grano medio, gruesodureza de la ligazón media

mittel/medium/moyen/medio

grob/coarse/gros/grueso



ISO 655 920 ...	798/750 375 523 750	798/750 375 533 750
L mm	6,5	6,5

für mittelharte Metall-Legierungen wie Chrom-Kobalt

Edelkorund Schleifräder (Al₂O₃), rosa
Keramische Bindung
Unmontiert
Bohrung Ø 1,8 mm
Korngröße mittel
Bindungshärte mittel

for medium hard metal alloys like chrome-cobalt

high-grade corundum abrasive wheels (Al₂O₃), pink
ceramic bond unmounted
Ø of centre hole 1,8 mm
grit size medium
bonding hardness medium

pour alliages métalliques moyen-durs comme chrome-cobalt

meules abrasives en corindon affiné (Al₂O₃), rose
liaison céramique non-monté
alésage Ø 1,8 mm
taille de grain moyen
dureté de liaison moyenne

para aleaciones metálicas media-duras como cromo-cobalto

abrasivos de corindon fino (Al₂O₃), rosa
ligazón cerámica sin montar
agujero Ø 1,8 mm
tamaño de grano medio
dureza de la ligazón media



ISO 625 900 ...	767/160 372 523 160	772/190 372 523 190	777/220 372 523 220
L mm	3,0	3,0	3,0

Schleifräder
 Abrasive wheels
 Meules abrasives
 Ruedas abrasivas

Zahntechnik
 Dental Technology
 Prothese Dentaire
 Protesis Dental

für weiche Metall-
 Legierungen

Edelkorund Schleifkörper
 (Al_2O_3), weiß
 Keramische Bindung
 Unmontiert
 Bohrung \varnothing 1,8 mm
 Korngröße mittel
 Bindungshärte hart

for soft metal alloys

high-grade corundum
 abrasives (Al_2O_3), white
 ceramic bond
 unmounted
 \varnothing of centre hole 1,8 mm
 grit size medium
 bonding hardness hard

pour alliages
 métalliques doux

abrasifs en corindon
 affiné (Al_2O_3), blanc
 liaison céramique
 non-monté
 alésage \varnothing 1,8 mm
 taille de grain moyen
 dureté de liaison dure

para aleaciones
 metálicas blandas

abrasivos de corindon fino
 (Al_2O_3), blanda
 ligazón cerámica
 sin montar
 agujero \varnothing 1,8 mm
 tamaño de grano medio
 dureza de la ligazón dura

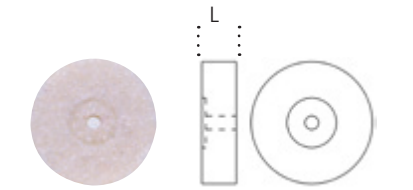

ISO 635 900 ...	768/160 373 524 160
L mm	4,5



Trennscheiben
Cutting-off discs
Disques à séparer
Discos separadores

für Metall-Legierungen

Faserverstärkt
Unmontiert
Bohrungen Ø 1,8mm

for metal alloys

fiber-reinforced
unmounted
Ø of centre hole 1,8mm

pour alliages métalliques

renforcé de fibres
non-monté
alésage Ø 1,8mm

para aleaciones metálicas

reforzado con fibra
sin montar
orificio Ø 1,8mm



	438/220	438/220	438/400	438/400
L mm	0,2	0,3	0,5	1,0

für Titan und Kunststoff

Unmontiert
Bohrungen Ø 1,8mm

for titanium and acrylic

unmounted
Ø of centre hole 1,8mm

pour titane et résine

non-monté
alésage Ø 1,8mm

para titanio y resina

sin montar
orificio Ø 1,8mm



	438T/260
L mm	0,4

Trennscheiben
Cutting-off discs
Disques à séparer
Discos separadores

für Keramik und Zirkon

for ceramics and zirconia

pour céramique et pour l'oxyde de zirconium

para cerámica y óxido de circonio

Faserverstärkt
Diamantdurchsetzt
Unmontiert
Bohrungen Ø 1,8mm

fiber-reinforced
diamond interspersed
unmounted
Ø of centre hole 1,8mm

renforcé de fibres
imprégné de diamant
non-monté
alésage Ø 1,8mm

reforzado con fibra
impregnado de diamante
sin montar
orificio Ø 1,8mm



Empfohlene Träger

recommended mandrel

recommended mandrin

recommended mandril

TOP MANDREL

Scheibenträger
disc mandrels
porto-disque
portadisco



303



303RS*

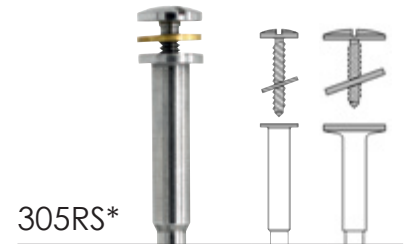

305RS*

	H/HP/PM ISO 300 104 603 391...	050
--	-----------------------------------	-----

	US-No W/RA/CA ISO 330 204 603 391...	303 050
	H/HP/PM ISO 330 104 603 391...	050

	US-No W/RA/CA ISO 330 204 604 391...	321 050	
	H/HP/PM ISO 330 104 604 391...	050	080

Set, Bohrerständler, Sonstiges

Set, bur bloc, Miscellaneous • Set, porte-fraises, Autres • Set, fresero Otros

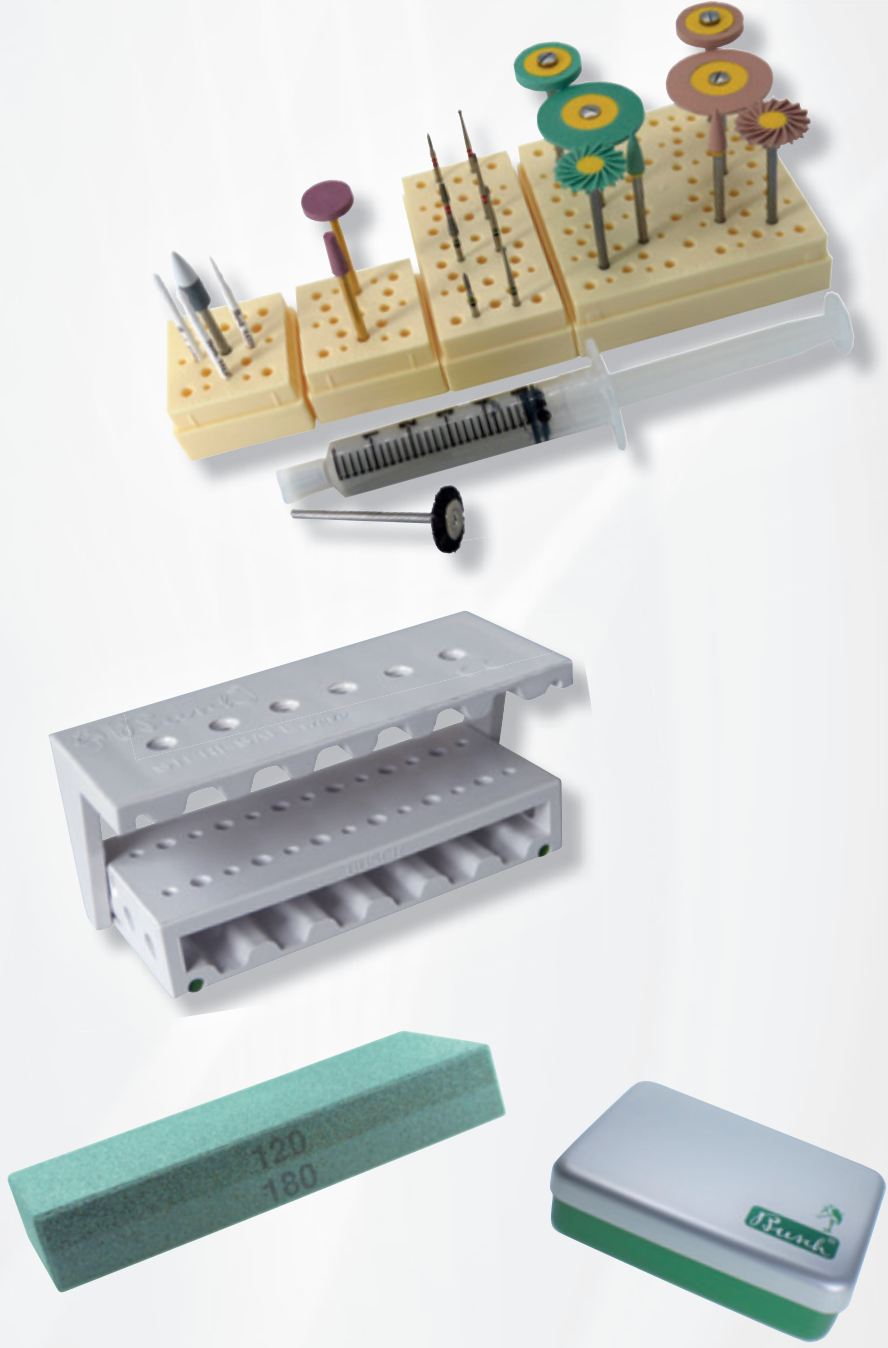

Set, Bohrerständer, Sonstiges

Set, Bur bloc, Miscellaneous • Set, Porte-fraises, Autres • Set, Fresero, Otros

Zirkon Workflow Set 164-165

STERI-SAFE 166-170

Bohrerständer, Alubox
Bur bloc, Alubox
Porte-fraises, Alubox
Fresero, Alubox 171

EVERCLEAR Mundspiegel, Abrichtdiamant
EVERCLEAR mouth mirrors, dressing diamond
Miroirs à bouche EVERCLEAR, diamant à dresser
Espejos de boca EVERLCEAR, recortador diamantado 172

Keramik Block, Reinigungsstein
ceramic block, dressing stone
bloque céramique, pierre à débouurrer
bloque de cerámica, piedra de limpieza 173



Push®

Zirkon Workflow Set

Let's workflow it...

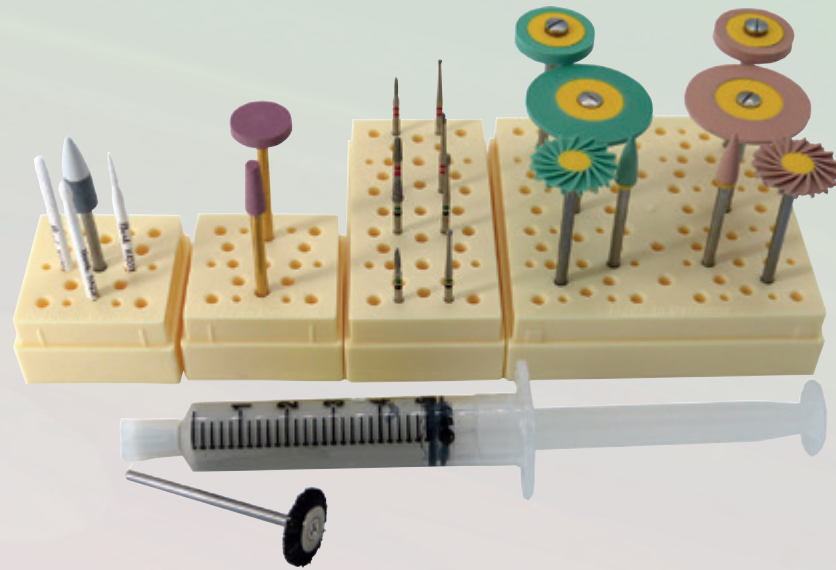

... mit dem Zirkon Workflow Set von der Weißlingsbearbeitung bis zur Politur alles in einem Set.

... with the zircon workflow set from processing pre-sintered zirconia to polishing all in one set.

... avec le workflow set de la zircone, du traitement de la zircone pré-frittée au polissage, tout en un.

... con el workflow set de zirconia, desde el procesamiento de zirconia presinterizada hasta el pulido, todo en uno.

Weißlingspolierer/
KERA Keramik-Fräser

- Raustrennen, Verputzen, Strukturieren mit Keramik-Fräsern
- Polieren mit dem 2 in 1 Polierer mittel/fein

polisher for pre-sintered zirconia/ KERA ceramic cutters

- separating, smoothing, structuring with ceramic cutters
- polishing with the 2 in 1 polisher medium/fine

polissoir pour zircone pré-frittée/ KERA fraises céramiques

- séparation, lissage, façonnage avec des fraises céramiques
- Polissage avec le polissoir 2 en 1 (moyen/fin)

Pulidor para zirconia presinterizada/ KERA fresas cerámicas

- separación, alisado, modelado con fresas cerámicas
- pulido con el pulidor 2 en 1 (medio/fino)

Step 1



HST/HP	9800	K433X	K426X	K423FX
ISO Ø	055	016	023	023

Diamantdurchsetzte Schleifkörper

- ohne Wasserkühlung einsetzbar
- Ausdünnen von Rändern, Formkorrekturen

diamond interspersed abrasives

- to be used **without** water cooling
- thinning of edges, shape corrections

abrasifs imprégnés de diamant

- à utiliser **sans** refroidissement à l'eau
- amincissement des bords, corrections de forme

abrasivos impregnados de diamante

- para uso **sin** refrigeración por agua
- afinamiento de bordes, correcciones de forma

Step 2

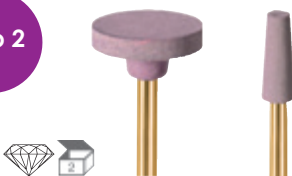

HST/HP	D702	D723
ISO Ø	120	040

Zirkon Workflow Set

ZIRAMANT Schleifer mit Spezialdiamantierung

filigrane Feinkorrekturen:
 • grün, schwarz: grobe Körnung
 • rot, rot: feine Körnung

ZIRAMANT instruments with special diamond coating

filigrée fine corrections:
 • green, black: coarse grit
 • red, red: fine grit

instruments ZIRAMANT avec revêtement spécial en diamant

corrections fines de filigrane
 • vert, noir: grain gros
 • rouge, rouge: grain fin

instrumentos ZIRAMANT con revestimiento especial de diamante

correcciones finas de filigrana
 • verde, negro: grano grueso
 • rojo, rojo: grano fino

Step 3



FG lg	6855Z	6860Z	8855Z	8860Z	FG x-lg	6801LZ	6838LZ	8801LZ	8838LZ
ISO Ø	025	014	021	010	ISO Ø	014	012	011	009

2-stufiges diamantdurchsetztes Poliersystem

1. türkis, gelb: mittel
 2. rosa, gelb: fein

2-step diamond interspersed polishing system

1. turquoise, yellow: medium
 2. pink, yellow: fine

systeme de polissage imprégné de diamant en 2 étapes

1. turquoise, jaune: moyen
 2. rose, jaune: fin

sistema de pulido impregnado de diamante en 2 etapas

1. turquesa, amarillo: medio
 2. rosa, amarillo: fino

Step 4

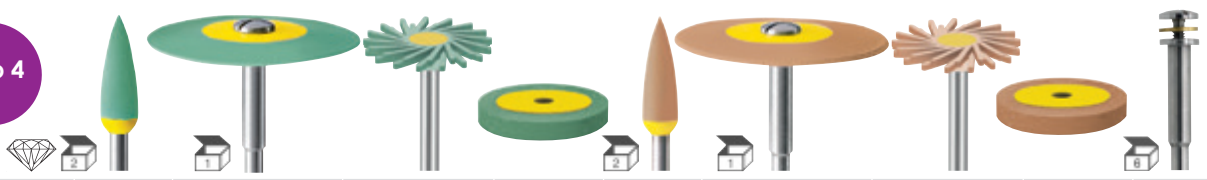

HST/HP	9854	9853	9855		9864	9863	9865		305RS
unmontiert				9856				9866	
unmounted									
ISO Ø	040	260	170	170	040	260	170	170	050

Bürste und Diamant-Polierpaste

• Hochglanzpolitur mit 3µ Diamantpaste

brush and diamond-polishpaste

• high shine polishing with 3µ diamond paste

brosse et pâte à polir diamantée

• polissage haute brillance avec pâte à polir diamantée 3µ

cepillo y pasta de pulir diamantada

• pulido de alto brillo con pasta de diamante 3µ

Step 5



HST/HP	9736
ISO Ø	140

Pferdehaarbürste, harte Borsten

horsehair brush, hard bristles

brosse en crin de cheval poils rigides

cepillo de crin de caballo cerdas duras



HST/HP	9646
--------	------

Hochglanzpolierpaste, Diamant (3µ)

High shine polishing paste, diamond (3µ)

pâte de polissage haute brillance diamant (3µ)

pasta de pulir diamantada de alto brillo (3µ)



Bush[®]

STERI-SAFE

Die STERI-SAFE Bohrerständer aus Medical Kunststoff mit den überzeugenden Vorteilen in Anwendung, Sicherheit und Hygiene:

- die offene Konstruktion für eine bessere Durchströmung im Sinne einer optimalen und effektiven Wiederaufbereitung
- der desinfizierbare und sterilisierbare Medical Kunststoff ist für alle praxisrelevanten Wiederaufbereitungsmaßnahmen geeignet
- der präzise schwenk- und arretierbare Sicherungsbügel für eine leichte Handhabung

The STERI-SAFE bur block of medical resin with outstanding advantages in respect of use, safety and hygiene:

- open design for better flow penetration ensuring optimum and effective reconditioning
- the medical resin material can be disinfected and sterilized with all reconditioning measures of practical relevance
- retaining clip can be precisely swivelled and locked in place for easy handling

Porte-fraises STERI-SAFE en résine médicale avec des avantages convaincants sur le plan de l'utilisation, de la sécurité et de l'hygiène:

- construction ouverte pour une meilleure circulation dans le cadre d'un reconditionnement optimal et efficace
- résine médicale pouvant être désinfectée et stérilisée avec toutes les mesures de retraitement dans les cabinets dentaires
- anse de sécurité précise pouvant être orientée et bloquée pour une utilisation aisée

Fresero STERI-SAFE, fabricado en resina medical, con ventajas que convencen en cuanto a aplicación, seguridad e higiene:

- la construcción abierta para un mejor perfusión en el sentido de una reutilización óptima y efectiva
- la resina medical se puede desinfectar y esterilizar con todas los métodos de reutilización relevantes en la práctica
- el arco de seguridad gira torio y bloqueable para un manejo fácil



ultraschallbeständig
resistant to ultrasound
résistant aux ultrasons
resistente para baños de ultrasonido



autoclavierbar bei 134°C
suitable for autoclaving at 134°C
peut être stérilisé dans l'autoclave à 134°C
resistente a autoclave con 134°C



thermodesinfektorbeständig
suitable for use in a thermal disinfectant
résistant à la désinfection thermique
resistente para el uso en aparatos de desinfección térmica



desinfektionsmittelbeständig
resistant to disinfectant
résistant aux désinfectants
resistente a medios de desinfección

STERI-SAFE_{pro}

Konzipiert für max. 24 Instrumente mit einer Gesamtlänge von 36 mm bis 56,5 mm
designed for max. 24 instruments with a total length of 36 mm to 56,5 mm
conçu pour max. 24 instruments d'une longueur totale de 36 mm à 56,5 mm
concebido para un máximo de 24 instrumentos con una longitud total entre 36 mm y 56,5 mm

5772+D



STERI-SAFE_{wave}

5773

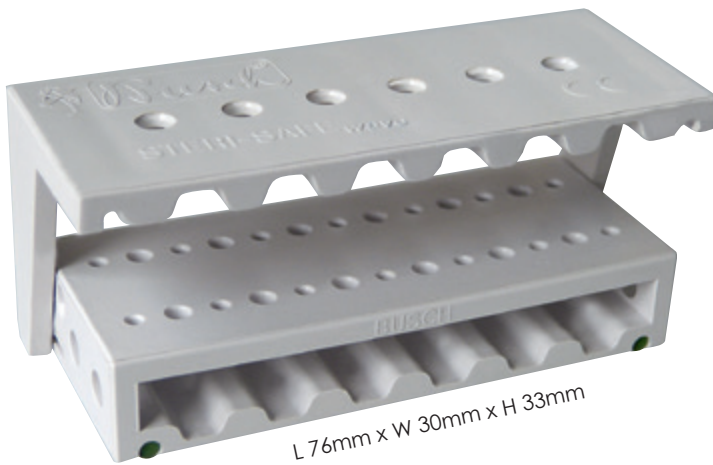

L 76mm x W 30mm x H 33mm

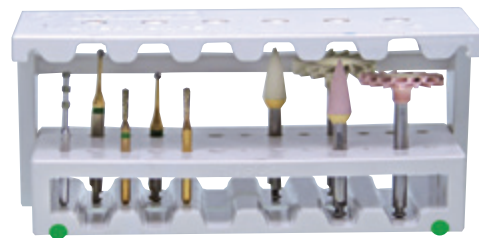

CE

Nicht nur ein Bohrerständer:

- bewahrt FG- und WST-Instrumente gleichzeitig auf
- einfacher und sicherer Transport
- anti-rutsch Farbkodiersystem
- geeignet für alle relevanten Aufbereitungsmethoden
- validiert durch ein unabhängiges Institut

Pas seulement un porte-fraises dentaires:

- stockage simultané des instruments FG et WST
- transport facile et sûr
- système antidérapant à code de couleur
- adapté à toutes les méthodes de retraitement pertinentes
- validé par un institut indépendant

Not just a bur block:

- holds FG and RA shank
- easy and safe transportation
- anti-slip colour coding system
- suitable for all relevant reconditioning methods
- validated by an independent institute

No sólo un soporte apra fresas dentales:

- almacena instrumentos FG y WST simultáneamente
- transporte sencillo y seguro
- sistema antideslizante de codificación por colores
- apto para todos los métodos de reprocesamiento relevantes
- validado por un instituto independiente



Push®

STERI-SAFE

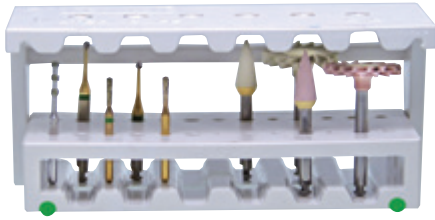

universell

Die innovative wave-Konstruktion dieses modernen sterilisierbaren Bohrerständers ermöglicht das sichere und gleichzeitige Handling von FG und WST Instrumenten in Standardlängen, vor, während und nach der Patientenbehandlung.

Von der Präparation bis zur abschließenden Politur haben Sie immer Ihre Instrumente beider Schaftarten griffbereit und übersichtlich in diesem Bohrerständer kombiniert.

max. 14 FG-Instrumente

mit einer Gesamt-Länge von 19 bis 24mm

max. 12 Wst-Instrumente

mit einer Gesamt-Länge von 22 bis 30mm

universal

The innovative wave design of this modern, sterilizable bur block permits safe handling of instruments with RA and FG shank in standard lengths before, while, and after treating patients.

From preparation to final polishing, all instruments with both types of shank are instantly at hand and clearly arranged together in this bur bloc.

max. 14 instruments with FG shank,

with an overall length from 19 mm to 24 mm

max. 12 instruments with RA shank,

with an overall length from 22 mm to 30 mm

universel

La nouvelle construction wave de ce porte-fraises moderne qui peut être stérilisé permet le maniement sûr des instruments avec tiges FG et CA de longueurs standards avant, pendant et après le traitement des patients.

De la préparation jusqu'au polissage final vous disposez toujours des instruments avec les deux tiges clairement arrangés à portée de main sur ce porte-fraises.

max. 14 instruments avec tige FG d'une longueur totale de 19 mm à 24 mm

max. 12 instruments avec tige CA d'une longueur totale de 22 mm à 30 mm

universal

STERI-SAFEwave es un fresero universal con un innovador soporte esterilizable que permite el manejo seguro y simultáneo de instrumentos rotatorios con mangos para turbinas y contra-ángulos.

Con este soporte para fresas de longitud estándar tendrá siempre todos sus rotatorios a mano, desde la preparación hasta el pulido final, y claramente identificados.

Espacio máximo para:

14 instrumentos FG con una longitud total de 19 a 24 mm;

12 instrumentos CA con una longitud total de 22 a 30 mm



sicher

Der Sicherungsbügel arriert im geschlossenen Zustand und sichert so alle Instrumente gegen Herausfallen, natürlich auch im Wiederaufbereitungskreislauf.

Zudem wird der Verschleiß der Arbeitsteile reduziert, da diese sich nicht berühren und gegenseitig schädigen. Klappen Sie den Sicherungsbügel nach hinten, um die gewünschten Instrumente zu entnehmen.

safe

The closing bracket is locked in place when closed and securely prevents the combination of instruments with RA and FG shanks from falling out, naturally also during the reprocessing cycle.

Swing the closing bracket to the rear in order to remove the required instruments.

sûr

L'anse de sécurité à l'état fermée est bloquée et évite les instruments avec tiges CA et FG de tomber, bien sûr aussi durant le procès de retraitement.

L'usure des parties travaillantes est en outre réduite, car celles-ci ne se touchent pas et ne peuvent pas s'endommager mutuellement. Rabattre l'anse de sécurité vers l'arrière pour prélever les instruments.

seguro

El fresero cuenta con un bloqueo de seguridad para cerrarlo, y así poder asegurar que los rotatorios no se caigan en ningún proceso del trabajo.

Utilizar STERI-SAFEwave reduce el desgaste de los instrumentos, ya que evitamos que se rocen entre sí.

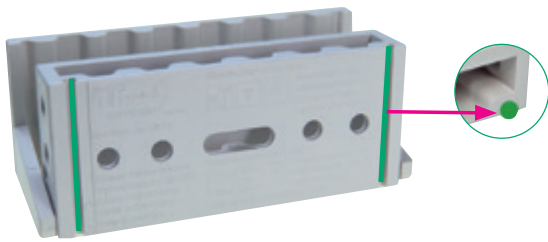

Art.-Nr. 5773-03
grün/green/
vert/verdes

systematisierbar

Der STERI-SAFEwave bietet Ihnen die Möglichkeit einer Farbkodierung.

Die in 5 Farben erhältlichen Silikonbänder haben einen doppelten Nutzen. Neben der Farbcodierung sichern sie einen rutschfesten Stand.

organized

The STERI-SAFEwave can also be colour-coded.

Available in five colours, the coloured strips serve a two-fold purpose. In addition to permitting colour-coding, they also enhance the non-slip stability of the bur bloc.



5773-01 STERI-SAFEwave SILIKONBAND ROT with silicone strip red, avec trait en silicone rouge, con tiras de silicona rojas

5773-02 STERI-SAFEwave SILIKONBAND GELB with silicone strip yellow, avec trait en silicone jaune, con tiras de silicona amarillos

5773-03 STERI-SAFEwave SILIKONBAND GRÜN with silicone strip green, avec trait en silicone vert, con tiras de silicona verdes

5773-04 STERI-SAFEwave SILIKONBAND BLAU with silicone strip blue, avec trait en silicone bleu, con tiras de silicona azules

5773-05 STERI-SAFEwave SILIKONBAND SCHWARZ with silicone strip black, avec trait en silicone noir, con tiras de silicona negras



Ersatz Silikonbänder/spare silicone strips
remplacement de traits en silicone/
tiras de silicona de recambio

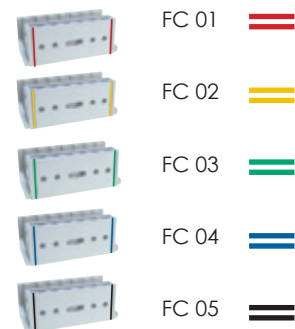

hygienisch

Im Rahmen des Wiederaufbereitungsprozesses profitieren Sie zum einen vom desinfizier- und sterilisierbaren Medical Kunststoff des STERI-SAFEwave und zum anderen von der Möglichkeit, ihn aufgrund seiner kompakten Abmessung im geschlossenen Zustand in bestehende Hygienekonzepte einzubinden (Sterilgutverpackung/ - Container).

Die offene Konstruktion des STERI-SAFEwave sowie der Verzicht auf spülschattenbildende und verschleißende Silikonrippen zur Instrumentenfixierung unterstützt eine bessere Durchströmung im Sinne einer optimalen und effektiven Wiederaufbereitung.

hygienic

In conjunction with the hygiene process, benefit from the advantages of the medical resin material of the STERI-SAFEwave allowing it to be disinfected and sterilized as well as the fact that its' size allows it to be integrated into existing hygiene concepts (sterile packaging / containers).

The open design of the STERI-SAFEwave ensures a better flow for optimum and effective reprocessing.

systematisé

Le STERI-SafeWave vous offre la possibilité d'un code couleur. Les traits en silicone disponibles dans 5 couleurs ont un double avantage. Outre le codage couleur, les traits en silicone garantissent un antidérapant.

organizable

STERI-SAFEwave le ofrece cintas de silicona de 5 colores diferentes para clasificar los rotatorios.

Además estas cintas para el código de colores, tienen una doble función, también hace que el soporte sea antideslizante.

hygienique

Dans le cadre du procès de retraitement vous profitez de la résine médicale STERI-SafeWave, qui peut être désinfecté et stérilisé et d'autre part de la possibilité de l'intégrer aux concepts d'hygiène existants en raison de ses dimensions (conditionnement/conteneur à articles stériles).

higiénico

El fresero STERI-SAFEwave está fabricado con plástico de uso médico que es completamente desinfectable y esterilizable. Por lo tanto, puede ser integrado en los protocolos de limpieza y desinfección de la clínica dental.

validiert



Die Reinigungsfähigkeit des STERI-SAFE_{wave} in Kombination mit den darin einbezogenen vorkontaminierten BUSCH Medizinprodukten wurde durch ein externes Institut validiert.

validé



L'aptitude au nettoyage du porte-fraises STERI-SAFE_{wave} en combinaison avec les instruments médicaux BUSCH précontaminés a été validée par un institut externe.

validated



The cleanability of STERI-SAFE_{wave} itself and in combination with typical BUSCH dental burs, grinders and cutters has been validated by an independent external institute.

validado



El proceso de limpieza del STERI-SAFE_{wave}, en combinación con los rotatorios Busch precontaminados y colocados en el fresero, ha sido validado y certificado por un instituto externo.

customized
& exclusive
set

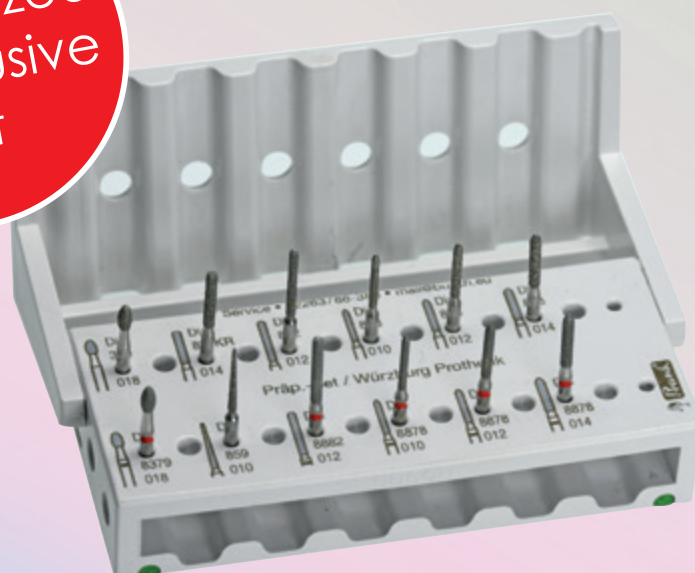

Auf Anfrage erstellen wir individuelle Sets mit Wunschbeschriftung.

On request, we can create individual sets with your favourite print.

Sur demande, nous créons des sets individuels avec l'inscription de votre choix.

Si lo desea, podemos crear juegos individuales con el etiquetado que desee.

Bohrerständer, Alubox
 bur bloc, Alubox
 porte-fraises, Alubox
 fresero, Alubox

Socket-System

Material: Polystyrol,
 Farbe: Elfenbein
 Aufnahmemöglichkeit:
 Zweifachsocket 5762:
 29 Löcher H/W +
 12 Löcher FG
 Vierfachsocket 5764:
 62 Löcher H/W +
 24 Löcher FG

stand-system

material: polystyrene,
 colour: ivory
 possible assortments:
 double stand 5762:
 29 holes HP/RA +
 12 holes FG
 quadruple stand 5764:
 62 holes HP/RA +
 24 holes FG

système de socles

matériau: polystyrène,
 couleur: Ivoire
 assortiments possibles:
 socle double 5762:
 29 orifices PM/CA +
 12 orifices FG
 socle quadruple 5764:
 62 orifices PM/CA +
 24 orifices FG

sistema de soportes

material: polistireno,
 color: marfil
 clasificación posible:
 zócalo doble 5762:
 29 agujeros PM/CA +
 12 agujeros FG
 zócalo cuadruple 5764:
 62 agujeros PM/CA +
 24 agujeros FG



5762



33 x 66 x 58 mm



5764



66 x 66 x 58 mm

Alubox

für Lager und Transport, Material: Aluminium eloxiert
 for carriage and storage, Material: Aluminium anodisé
 pour le stockage et le transport, Material: Aluminium anodized
 pard transportación y almacenar, Material: Aluminium anodizado



5780



120 x 86 x 36 mm

EVERCLEAR
 Mundspiegel

Bleiben nach kurzem
 Anwärmen längere Zeit klar
 Höchste Reflektion
 Desinfizierbar, sterilisierbar

EVERCLEAR
 mouth mirrors

stay clear longer if shortly
 warmed
 maximum reflection
 disinfectable, sterilizable

miroirs à bouche
EVERCLEAR

après un court préchauf-
 fage les miroirs restent plus
 longtemps clair
 réflexion maximale
 peut être désinfecté et stérilisé

espejos de boca
EVERCLEAR

no se empañarán por buen
 espacio de tiempo si se
 calienten brevemente
 reflexión máxima se puede
 desinfectar y esterilizar

442



plan
 plain
 plat
 plano

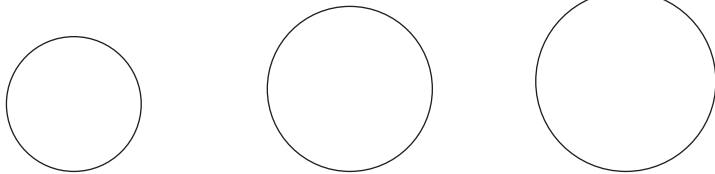



Ø mm	2 18	4 22	5 24
------	---------	---------	---------

443



hohl
 concave
 concave
 cóncavo







Ø mm		4 22	5 24
------	--	---------	---------

Abrichtdiamant
dressing diamond
diamant à dresser
recortador diamantado

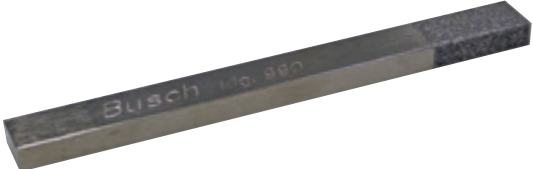
990





120 x 12 x 6 mm

Abziehen= Reinigen von zugesetzten Schleifkörpern und Polierern/sharpening= cleaning of clogged abrasives and polishers/
 dresser= nettoyer des abrasifs et polissoirs encrassés/afilarse= limpieza de abrasivos y pulidores

Abrichten= Formen von Schleifkörpern und Polierern/dressing= shaping of abrasives and polishers/
 rectifier= façonnage des abrasifs et polissoirs/recortar= dar forma/tallar abrasivos y pulidores

Keramik Block, Reinigungsstein
ceramic block, dressing stone
bloque céramique, pierre à débourrer
bloque de cerámica, piedra de limpieza

Keramik Block

ceramic block

zum Abrichten und Abziehen von Polierern und Schleifkörpern
for dressing of polishers and abrasives

bloque céramique

pour dresser et rectifier les polissoirs et abrasifs

bloque de cerámica

para recortar y afilar pulidores y abrasivos

groß, grün, feine und mittlere Körnung
large, green, fine and medium grit
grand, vert, taille de grain fin et moyen
grande, verde, grano fino y medio

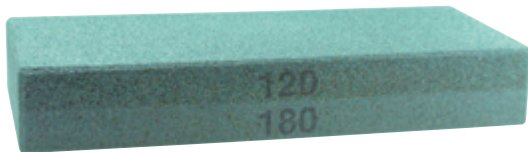

440



120 x 50 x 20 mm

klein, hellblau, grobe Körnung
small, light blue, coarse grit
petit, bleu clair, taille de grain gros
pequeño, azul claro, grano grueso

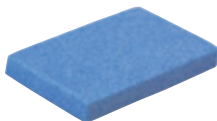

441



20 x 33 x 4 mm

Reinigungsstein

vor der Anwendung anfeuchten
Entfernen von festhaftenden Partikeln an Diamantschleifer bei einer Drehzahl von 1.000 - 5.000 min⁻¹

dressing stone

dampen before use for the removal of particles sticking to diamond instruments at an instrument speed of 1.000-5.000 rpm.

pierre à débourrer

mouiller avant l'utilisation pour enlever les particules adhérentes aux instruments diamantés, en travaillant à une vitesse entre 1.000 et 5.000 tours/min⁻¹.

piedra de limpieza

mojar antes de la utilización para eliminar partículas pegadas en los instrumentos diamantados, trabajando con una velocidad de 1.000-5.000 revoluciones/minuto



599



100 x 25 x 14 mm

Basisinformationen

Basic information • Informations de base • Información básica



Basisinformationen

Basic information • Informations de base • Información básica

Medizinproduktrecht Sicherheits-, Gebrauchs- und Hygiene-Empfehlungen Medical Devices Law Safety, usage and hygiene recommendations Droit des dispositifs médicaux Recommandations de sécurité, d'utilisation et d'hygiène Derecho de productos sanitarios Recomendaciones de seguridad, uso e higiene	176
Aufbereitung und Reinigung Preparation and cleaning Traitement et nettoyage Desinfección y limpieza	177
Pictogramme Pictographs Pictographies Pictogramas	178
Schaffdaten, Produktetikett Data of shanks Product label Donnés de tiges, Étiquette du produit Datos de los mangos, Etiquetas de los productos	179
Technische Daten Technical data Données techniques Datos técnicos	180-183
Drehzahlempfehlungen Polierer, Bürsten und Schleifkörper recommended r.p.m. polishers, brushes and abrasives recommandations de vitesse polissoirs, brosses et abrasives recomendaciones de velocidad pulidores, cepillos y abrasivos	184-185
Diamant Körnung Diamond grit Diamantés grain Diamantados grano	186
ZIRAMANT Körnung ZIRAMANT grit Grain ZIRAMANT Grano ZIRAMANT	187



Medizinprodukterecht/Medical Devices Law/Droit des dispositifs médicaux/
Derecho de productos sanitarios

Grundlage für Medizinprodukte (CE-Kennzeichnung)

Auf Basis der EG-Richtlinie 93/42/EWG – auch MDD genannt – wurde 1994 in Deutschland das Medizinproduktegesetz (MPG) verabschiedet. Dieses Gesetz und die daran anknüpfenden Verordnungen galten bis zum 25. Mai 2021 und wurden durch die europäische Verordnung (EU)2017/745 des Europäischen Parlaments und des Rates – auch MDR genannt – ersetzt. Die Forderungen an ein Qualitätsmanagementsystem gemäß der Norm DIN EN ISO 13485 erfüllt BUSCH & CO. GmbH & Co. KG seit 1998. Eine erfolgreiche Umsetzung wird regelmäßig im Rahmen eines jährlichen Audits bestätigt.

Auf Grund dieses Verfahrens ist BUSCH & CO. GmbH & Co. KG gesetzlich verpflichtet und berechtigt, für ihre Medizinprodukte das CE-Zeichen zu verwenden.

Bei allen BUSCH Instrumenten für die Zahnmedizin handelt es sich um Medizinprodukte, die als solche durch das CE-Zeichen mit der 4-stelligen Nummer 0124 als Konformitätsnachweis auf dem Etikett jeder einzelnen Verpackung erkennbar sind.

Basis for medical devices (CE marking)

Based on EC directive 93/42/EEC – Medical Devices Directive, or MDD – the Medizinproduktegesetz (Medical Devices Act) was passed into law in Germany in 1994. This law and its associated regulations remained in force until 25 May 2021, when they were replaced by European Regulation (EU)2017/745 of the European Parliament and of the Council, known as the MDR.

BUSCH & CO. GmbH & Co. KG has satisfied the requirements for a compliant quality management system according to the DIN EN ISO 13485 standard since 1998.

The successful implementation of the system is confirmed regularly as part of an annual audit. By virtue of this procedure, BUSCH & CO. GmbH & Co. KG is legally obliged and entitled to use the CE mark for its medical devices.

All instruments manufactured by BUSCH for dentistry are medical devices which are identifiable as such from the CE marking and the four-digit number 0124 on the label of each individual package that provide proof of conformity.

La loi sur les produits médicaux en tant que base pour les produits médicaux (marquage CE)

Sur la base de la directive européenne 93/42/CEE – également appelée MDD (Medical Device Directive) – l'Allemagne a adopté en 1994 la loi sur les dispositifs médicaux (Medizinproduktegesetz ou MPG). Cette loi et les règlements y afférents étaient en vigueur jusqu'au 25 mai 2021, date à laquelle ils ont été remplacés par le règlement européen (UE)2017/745 du Parlement européen et du Conseil – également appelé MDR (Medical Device Regulation). BUSCH & CO. GmbH & Co. KG répond aux exigences d'un système de gestion de la qualité conforme à la norme DIN EN ISO 13485 depuis 1998. Une mise en œuvre réussie est régulièrement confirmée dans le cadre d'un audit annuel. Sur la base de cette procédure, BUSCH & CO. GmbH & Co. KG est légalement tenue et autorisée à utiliser le marquage CE pour ses produits médicaux. Tous les instruments BUSCH pour la odontologie sont des dispositifs médicaux, identifiables en tant que tels par le marquage CE avec le numéro à 4 chiffres 0124 apposé sur l'étiquette de chaque emballage individuel comme preuve de conformité.

La Ley de Productos Sanitarios como base para los productos medicos (marcado CE)

La ley sobre productos sanitarios se aprobó en Alemania en 1994 tomando como base la Directiva CE 93/42/CEE, también denominada MDD por sus siglas en inglés. Tanto esta ley como los reglamentos asociados se aplicaron hasta el 25 de mayo de 2021. Fue entonces cuando entró en vigor el Reglamento Europeo (EU)2017/745 del Parlamento Europeo y del Consejo, también denominado MDR por sus siglas en inglés. Desde 1998, en BUSCH & CO. GmbH & Co. KG cumplimos los requisitos de un sistema de gestión de calidad conforme a la norma DIN EN ISO 13485. Nuestras auditorías anuales confirman la correcta implementación del sistema.

Este procedimiento nos obliga y nos autoriza a usar la marca CE para nuestros productos sanitarios. Todos los instrumentos BUSCH para odontología productos sanitarios que pueden identificarse mediante la marca CE y el número de cuatro cifras 0124 que figuran en las etiquetas de todos los envases a modo de certificado de conformidad.

WICHTIG! • IMPORTANT! • IMPORTANT! • IMPORTANTE!

Die aktuellen Aufbereitungs-Empfehlungen für rotierende Instrumente finden Sie immer unter www.busch.eu



The current reprocessing recommendations for rotating instruments can always be found at www.busch.eu



Las recomendaciones actuales para el reprocesamiento de los instrumentos rotatorios pueden consultarse en www.busch.eu



Las recomendaciones actuales para el reprocesamiento de los instrumentos rotatorios pueden consultarse en www.busch.eu



Aufbereitung/Reinigung (manuell) • Preparation/Cleaning (manual)
Traitement/Nettoyage (à la main) • Desinfección/Limpieza (a mano)

Wichtige Hinweise:

Angemessene Auswahl von qualifizierten Reinigern/Desinfektionsmittel unter besonderer Beachtung der Materialfreundlichkeit; kein Einsatz von Haushaltsreinigern; keine Säuren/Laugen.

Konsequente Dosierung (keine Überdosierung) entsprechend den Herstellerangaben; Verdunstung bei mehrtägiger Verwendung von Reiniger-/Desinfektionsmittel-Bädern berücksichtigen (dabei verdunstet nicht nur das Wasser, die chemischen Inhaltsstoffe nehmen zu).
Fertiglösungen sind gegenüber Konzentraten vorzuziehen.

Einhaltung der maximal zulässigen Verweilzeiten in Reinigern/Desinfektionsmitteln entsprechend der Herstellerangaben.

Bei Missachtung droht Korrosion an den Instrumenten, die die Leistung, Stabilität und Oberflächenbeschaffenheit beeinträchtigen kann und ein vorzeitiges Aussondern erfordert.

Important information:

Select appropriate qualified cleaners/ disinfectants giving special regard to material friendliness; do not use any household detergents; do not use acids or alkaline solutions

Use consistent dosing (no overdose) according to the manufacturer's specifications; take evaporation into account when using cleaner/ disinfectant baths for several days (not only water evaporates, the concentration of chemical ingredients will increase).

Ready-to-use solutions are preferable compared to concentrates.

Comply with the maximum permissible dwell times in cleaners/disinfectants according to the manufacturer's specifications.

Failure to observe this warning may result in corrosion of the instruments, which will affect their performance, stability and surface texture requiring them to be discarded prematurely.

Informations importantes:

Choix adéquat de nettoyeurs/ désinfectants adaptés sous prise en considération particulière de la compatibilité avec les matériaux ; pas d'utilisation de nettoyeurs domestiques ; pas d'acides/lessives.

Dosage conséquent (pas de surdosage) selon les indications des fabricants ; tenir compte de l'évaporation lors d'une utilisation sur plusieurs jours des bains nettoyeurs/désinfectants (l'eau ne s'évapore ici pas seulement, les substances chimiques augmentent).
La préférence doit être donnée aux solutions prêtes à l'emploi plutôt qu'à des produits concentrés.

Respect des temps de séjour maximaux admissibles dans les nettoyeurs/ désinfectants conformément aux indications des fabricants.

Simon, les instruments pourraient se corroder, ce qui pourrait nuire aux performances, à la stabilité et à la finition et nécessiter une élimination prématurée.

Indicaciones importantes:

Selección adecuada de productos de limpieza calificados o desinfectantes prestando especial atención a las características del material; no se pueden utilizar productos de limpieza domésticos; ácidos ni soluciones alcalinas.

Dosificación coherente (sin sobredosis) de acuerdo con los datos del fabricante; tener en cuenta la evaporación en caso de utilizar durante varios días desinfectantes o productos de limpieza para baños (no solo se evapora el agua, sino que también aumentan las sustancias químicas).
Es preferible usar soluciones listas para su uso a concentrados.

Cumplimiento de los tiempos de permanencia máximos permitidos en productos de limpieza o desinfectantes de acuerdo con las instrucciones del fabricante.







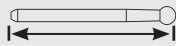
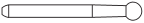

En caso de incumplimiento, los instrumentos pueden corroerse, cosa que puede afectar la eficacia, la estabilidad y el acabado profesional. Puede adelantar el apartamiento de la fresa.

Symbole/symbols/symboles/signos

	Kavitätenpräparation cavity preparation préparation cavitaire preparación de cavidades		Prophylaxe prophylaxis prophylaxie profilaxia
	Kronenpräparation crown preparation préparation coronaire preparación coronaria		Aufbohren alter Füllungen removal of old fillings retrait des vieilles obturations extracción de obturaciones
	Füllungsbearbeitung working on fillings préparation des obturations preparación de obturaciones		Kronentrennen crown cutting séparation des couronnes separación de coronas
	Kunststofftechnik acrylic technique technique acrylique técnica de plásticos para prótesis		Kieferchirurgie jaw surgery chirurgie maxillo-faciale cirugía maxilofacial
	Wurzelglättung root planing surfaçage radiculaire alisamiento de raíces		Modellherstellung model fabrication fabrication de modèles fabricación de modelos
	Kieferorthopädie orthodontics orthodontie ortodoncia		Feinwerktechnik precision technique technique de fraisage técnica fresado de precisión
	Kronen- und Brückentechnik crown and bridge technique technique de couronnes et bridges técnica de coronas y puentes		Nicht schneidende Spitze non cutting tip pointe non coupante punta roma (sin filos cortantes)
	Modellherstellung model fabrication fabrication de modèles fabricación de modelos		Abgesetzte nicht schneidende Spitze stapped non cutting tip pointe décalé non coupante escalonada punta no cortante
	Modellgusstechnik model casting technique technique de squelette técnica de colado de metal		Nicht zur Wiederverwendung do not reuse ne pas réutiliser no reutilizable
	Wurzelkanalaufbereitung root canal preparation traitement endodontique tratamiento endodóntico		Diamantdurchsetzt diamond interspersed imprégné de diamant impregnado de diamante
	Bearbeiten von Zirkonoxid working on zirconia traitement de l'oxyde de zirconium elaboración del óxido de zirconio		Packungseinheit packing unit unité d'emballage cantidad de envase
	Verblend-/Keramiktechnik veneer and ceramic technique technique de revêtement et céramique técnica de revestimiento y cerámica		

Schafftdaten, Produktetikett
 data of shanks, product label
 donnés des tiges, étiquette de produit
 datos de los mangos, etiquetas de los productos

Schafftdaten/data of shanks/donnés des tiges/datos de los mangos

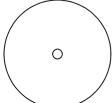
Arten/ types/ tipos/ tipos		∅		ISO
FG		1,60 mm	19 mm	314
FG lg		1,60 mm	21 mm	315
FG x-lg		1,60 mm	25 mm	316
W/RA/CA/CA		2,35 mm	22 mm	204
W lg/RA lg/CA lg/CA lg		2,35 mm	26 mm	205
W x-lg/RA x-lg/CA x-lg/CA x-lg		2,35 mm	34 mm	206
H kurz/HP short/PM courte/PM corta		2,35 mm	34 mm	103
H/HP/PM/PM		2,35 mm	44,5 mm	104
H lg/HP lg/PM lg/PM lg		2,35 mm	64,5 mm	105
	 unmontiert unmounted non-monté sin montar	mit Bohrung/with hole/ avec alésage/con perforación 1,7 mm/1,8 mm		900

Konstruktionsbedingte Längenabweichungen vorbehalten/Constructional length differences reserved/divergences de longueur conditionnées par la fabrication sont réservées/divergencias de la longitud por razones de fabricación reservadas

Produktetikett/product label/étiquette de produit/etiquetas de los productos



Wir versehen jede unserer Verpackungen mit einem ausführlichen Produkt-Etikett:

- a+b UDI/HIBC-Code
- c BUSCH Artikel-Nr.
- d1 UDI-Symbol
- d2 CE-Zeichen
- d3 Medizinprodukt-Symbol
- e-g Hersteller-Adresse (BUSCH)
- h LOT-Nummer
- i maximal zulässige Umdrehungszahl;
- j Material- und Schafftbezeichnung
- k Referenzsymbol, BUSCH-Nr. und Größe
- L Herstellungsdatum, Hinweis auf weitere Infos in BUSCH-Katalogen, homepage

We provide each of our packagings with a detailed product label:

- a+b UDI/HIBC-Code
- c BUSCH Part-No.
- d1 UDI-Symbol
- d2 CE-mark
- d3 symbol for medical device
- e-g manufacturer's address
- h LOT-number
- i max. admissible rpm
- j material-and shank description
- k reference symbol, BUSCH-number and size
- L date of manufacture, advice of further information in BUSCH-catalogues; homepage

Sur chacun de nos emballages se trouve une étiquette détaillée:

- a+b UDI/le code HIBC
- c BUSCH numero d'article
- d1 sybole UDI
- d2 marquage CE
- d3 symbole de dispositif médical
- e-g adresse du fabricant
- h numéro du lot
- i la vitesse de rotation max. admissible
- j désignation du matériel et de la tige figure et taille
- k symbole de référence, figure et taille BUSCH
- L date de fabrication, indications pour plus d'informations dans les catalogues BUSCH; site d'internet

En cada caja mencionamos los datos siguientes:

- a+b código UDI/HIBC
- c BUSCH número de artículo
- d1 símbolo UDI
- d2 marcado CD
- d3 símbolo de producto sanitario
- e-g dirección del fabricante
- h número de lote
- i no. de revoluciones máximas admisible
- j tipo de material y del mango
- k símbolo de referencia, código de BUSCH y tamaño
- L fecha de fabricación, indicaciones para mayor información en nuestros catálogos; pagina web



Technische Daten
technical data
données techniques
datos técnicos

Diamant/diamond/diamant/diamante

Diamant

Synthetisches blockiges Korn oder Naturkorn in anwendungsspezifischer Größe

Schaftmaterial

Rostsicherer Stahl

Bindungsaufbau

Dämpfungsschicht
Bindeschicht
Hart- und Glanzschicht

Schaft-Durchmesser

FG 1,6 mm (ISO 314)
FG lg 1,6 mm (ISO 315)
FG-xlg 1,6 mm (ISO 316)
W 2,35 mm (ISO 204)
H 2,35 mm (ISO 104)

Arbeitsteil-Durchmesser

0,7-30 mm

Rundlaufgenauigkeit

Besser als Normen

Normen

DIN, EN, ISO

Max. zul. Umdrehungszahl

Auf jeder Packung angegeben

diamond

synthetic block-like grits or natural grit in a size suitable for specific applications

material of shank

stainless steel

bonding structure

damping layer
bonding layer
hard and brilliance layer

Shank diameter

FG 1,6 mm (ISO 314)
FG lg 1,6 mm (ISO 315)
FG-x-long 1,6 mm (ISO 316)
RA 2,35 mm (ISO 204)
HP 2,35 mm (ISO 104)

working part diameter

0,7-30 mm

exact concentricity

Superior to standards

standards

DIN, EN, ISO

maximum admissible speed

Indicated on each package

diamant

grains synthétiques ou grains naturels aux dimensions spécifiques en fonction des applications.

matériau de la tige

acier inoxydable

structure de l'adhésion

couche d'amortissement
couche de liage
couche dure et brillante

diamètre de la tige

FG 1,6 mm (ISO 314)
FG lg 1,6 mm (ISO 315)
FG-x-longue 1,6 mm (ISO 316)
CA 2,35 mm (ISO 204)
PM 2,35 mm (ISO 104)

diamètre de la partie travaillante

0,7-30 mm

concentricité

supérieure aux normes

normes

DIN, EN, ISO

vitesse maximale admissible

indiquée sur chaque boîte

diamante

granos sintéticos o granos naturales en dimensiones adecuadas para las aplicaciones

material del mango

Acero inoxidable

estructura de unión

capa de amortiguación
capa de fijación
capa dura y de brillo

diámetro del mango

FG 1,6 mm (ISO 314)
FG lg 1,6 mm (ISO 315)
FG-x-largo 1,6 mm (ISO 316)
CA 2,35 mm (ISO 204)
PM 2,35 mm (ISO 104)

diámetro de la parte de fresa-

do 0,7-30 mm

concentricidad

Superior a las normas

normas

DIN, EN, ISO

velocidad máxima admitida

de revolución
indicada en cada cajita

Polierer, Bürsten, Schwabbel und Träger/polishers, brushes, polishing buffs and mandrels/ polissoirs, brosses, disques à polir mandrins/pulidores, cepillos, discos de trapos mandriles

Material Polierer

Silikon, Polyurethan (PUR), Polyester

Material Bürsten

Zahnmedizin: Polyamid
Zahntechnik: Naturborsten

Schwabbel

Zahntechnik
Cambric, Wildleder,
Baumwolle, Microfaser

Träger

hochwertiger Spezialstahl,
rostsicher oder vernickelt

Bindungshärte

supersoft, soft, weich, mittel,
hart

Schleifmittel

Siliziumkarbit (SiC)
Diamant
Edelkorund (Al₂O₃)
Bims

Korngröße

extra fein, fein,
mittel, grob

Schaftmaterial

rostsicherer Stahl oder
vernickelt
Kunststoff

material polishers

silicone, polyurethan (PUR),
polyester

material brushes

dentistry: polyamide
dental technique: bristle

polishing buffs

dental technique
cambric, suede,
cotton microfiber

mandrels

high-grade special steel,
stainless or nickel plated

bond hardness

super soft, soft,
medium, hard

abrading medium

silicone carbide (SiC)
diamond
high grade corundum
pumice

grit size

extra fine, fine, medium,
coarse

shank material

stainless steel or
nickel-plated
plastic

matériaux polisseurs

silicone, polyuréthane (PUR),
polyester

matériaux brosses

odontologie: polyamide
prothèse dentaire: poils naturels

disques à polir

prothèse dentaire
cambrai, suède,
coton micro-fibre

mandrins

acier de qualité supérieure,
inoxydable ou nickelage

dureté de liaison

super soft, soft, doux,
moyen, dur

composites abrasifs

carbure de silicium (SiC)
diamant
corindon affiné (Al₂O₃)
ponce

taille de grain

extra fin, fin, moyen, gros

matériaux de la tige

Acier inoxydable ou nickelage
Matière plastique

material pulidores

silicona, poliuretano (PUR),
poliéster

material cepillos

odontología: poliamid protesís
dental: cerdas naturales

discos pulidores

protesis dental
cambayón, gamuza,
algodón micro fibra

mandriles

acero especial de alta calidad,
inoxidable o niquelado

dureza de la ligazón

muy suave, suave, blanda,
media, dura

material abrasivo

carburo de silicio (SiC)
diamante
corindón fino (Al₂O₃)
piedra pómez

tamaño de grano

extra fino, fino, medio, grueso

material del mango

Acero inoxidable o
niquelado
Plástico

Gesamtlängen, Schaft ISO
 H 47,0 - 58,0 mm 104
 W 22,0 - 31,0 mm 204
 FG 21,0 - 25,0 mm 314

Schaft-Durchmesser
 H 2,35 mm - 0,016 mm
 W 2,35 mm - 0,016 mm
 FG 1,60 mm - 0,010 mm

Arbeitsteil-Durchmesser
 3,0 - 26,0 mm
 Die Angabe ISO Ø erfolgt
 in 1/10 mm.

Normen
 DIN, EN, ISO

Max. zul. Umdrehungszahl
 auf jeder Packung angege-
 ben

total length, shank ISO
 HP 47,0 - 58,0 mm 104
 RA 22,0 - 31,0 mm 204
 FG 21,0 - 25,0 mm 314

shank diameter
 HP 2,35 mm - 0,016 mm
 RA 2,35 mm - 0,016 mm
 FG 1,60 mm - 0,010 mm

working part diameter
 3,0 - 26,0 mm
 the ISO diameter is mentioned
 in one 10th of a millimetre.

standards
 DIN, EN, ISO

max. admissible speed
 mentioned on each package

longueur totale, tige ISO
 PM 47,0 - 58,0 mm 104
 CA 22,0 - 31,0 mm 204
 FG 21,0 - 25,0 mm 314

diamètres des tiges
 PM 2,35 mm - 0,016 mm
 CA 2,35 mm - 0,016 mm
 FG 1,60 mm - 0,010 mm

**diamètres de la partie
 travaillante**
 3,0 - 26,0 mm L'indication ISO
 Ø en 1/10 mm

normes
 DIN, EN, ISO

vitesse maximum admise
 indiquée sur chaque boîte

longitud total, mango ISO
 PM 47,0 - 58,0 mm 104
 CA 22,0 - 31,0 mm 204
 FG 21,0 - 25,0 mm 314

diámetro del mango
 PM 2,35 mm - 0,016 mm
 CA 2,35 mm - 0,016 mm
 FG 1,60 mm - 0,010 mm

**diámetro de la parte de
 fresado**
 3,0 - 26,0 mm El diámetro
 ISO Ø significa 1/10 mm.

normas
 DIN, EN, ISO

**velocidad máxima
 admisible**
 indicada en cada cajita

Schleifkörper/abrasives/abrasifs/abrasivos

Schleifmittel
 Siliziumkarbid (SiC)
 Edelkorund (Al₂O₃)
 Diamant

Korngröße
 extra fein, fein, mittel,
 grob

Bindungsart
 Keramisch, Magnesit,
 Kunstharz
 synthetisch

Bindungshärte
 weich, mittel, hart,
 extra-hart

Formgebung
 Pressen, Schleifen

Schaftmaterial
 rostsischerer Stahl

Gesamtlängen
 H 44,3 - 51,0 mm
 W 22,7 - 29,5 mm
 FG 21,0 - 25,0 mm

Schaft-Durchmesser
 H 2,35 - 0,016 mm
 W 2,35 - 0,016 mm
 FG 1,60 - 0,010 mm

Arbeitsteil-Durchmesser
 1,8 - 75,0 mm
 Die Angabe ISO Ø erfolgt
 in 1/10 mm.

Normen
 DIN, EN, ISO

Max. zul. Umdrehungszahl
 auf jeder Packung
 angegeben

abrasive
 silicon carbide (SiC)
 high-grade corundum (Al₂O₃)
 diamond

grit size
 extra fine, fine, medium,
 coarse

bonding
 ceramic, magnesite, resin
 resin
 synthetic

bonding hardness
 soft, medium, hard
 x-hard

shaping
 pressing, grinding

material of shanks
 stainless steel

total length
 HP 44,3 - 51,0 mm
 RA 22,7 - 29,5 mm
 FG 21,0 - 25,0 mm

shank diameter
 HP 2,35 - 0,016 mm
 RA 2,35 - 0,016 mm
 FG 1,60 - 0,010 mm

working part diameter
 1,8 - 75,0 mm
 The ISO diameter is
 mentioned in one 10th
 of a millimetre.

standards
 DIN, EN, ISO

max. admissible speed
 mentioned on each
 package

produits abrasifs
 carbure de silicium (SiC)
 corindon affiné (Al₂O₃)
 diamant

taille de grain
 extra fin, fin, moyen,
 gros

liaison
 céramique, magnésite,
 résine
 synthétique

dureté de liaison
 doux, moyen, dur
 extra dur

façonnage
 presser, meuler

matériau des tiges
 acier inoxydable

longueur totale
 PM 44,3 - 51,0 mm
 CA 22,7 - 29,5 mm
 FG 21,0 - 25,0 mm

diamètres des tiges
 PM 2,35 - 0,016 mm
 CA 2,35 - 0,016 mm
 FG 1,60 - 0,010 mm

**diamètres de la partie
 travaillante**
 1,8 - 75,0 mm
 l'indication ISO Ø
 en 1/10 mm

normes
 DIN, EN, ISO

vitesse maximum admise
 indiquée sur chaque boîte

material abrasivo
 carburo de silicio (SiC)
 corindón fino (Al₂O₃)
 diamante

tamaño de grano
 extra fino, fino, medio,
 grueso

ligazón
 Cerámica, magnesita,
 resina
 sintética

dureza de la ligazón
 blanda, media, dura
 extra dura

dar forma
 presionar, amolar

material del mango
 Acero inoxidable

longitud total
 PM 44,3 - 51,0 mm
 CA 22,7 - 29,5 mm
 FG 21,0 - 25,0 mm

diámetro del mango
 PM 2,35 - 0,016 mm
 CA 2,35 - 0,016 mm
 FG 1,60 - 0,010 mm

**diámetro de la parte de
 fresado**
 1,8 - 75,0 mm
 el diámetro ISO Ø significa
 1/10 mm.

Normas
 DIN, EN, ISO

**velocidad máxima
 admisible**
 indicada en cada cajita



Busch[®]

Schaffkennzeichnung/Technische Daten
Shank of labelling/Technical data
Inscription des tiges/Données techniques
Denominación de mangos/Datos técnicos

Schaffkennzeichnung/shank of labelling/inscription des tiges/denominación de mangos

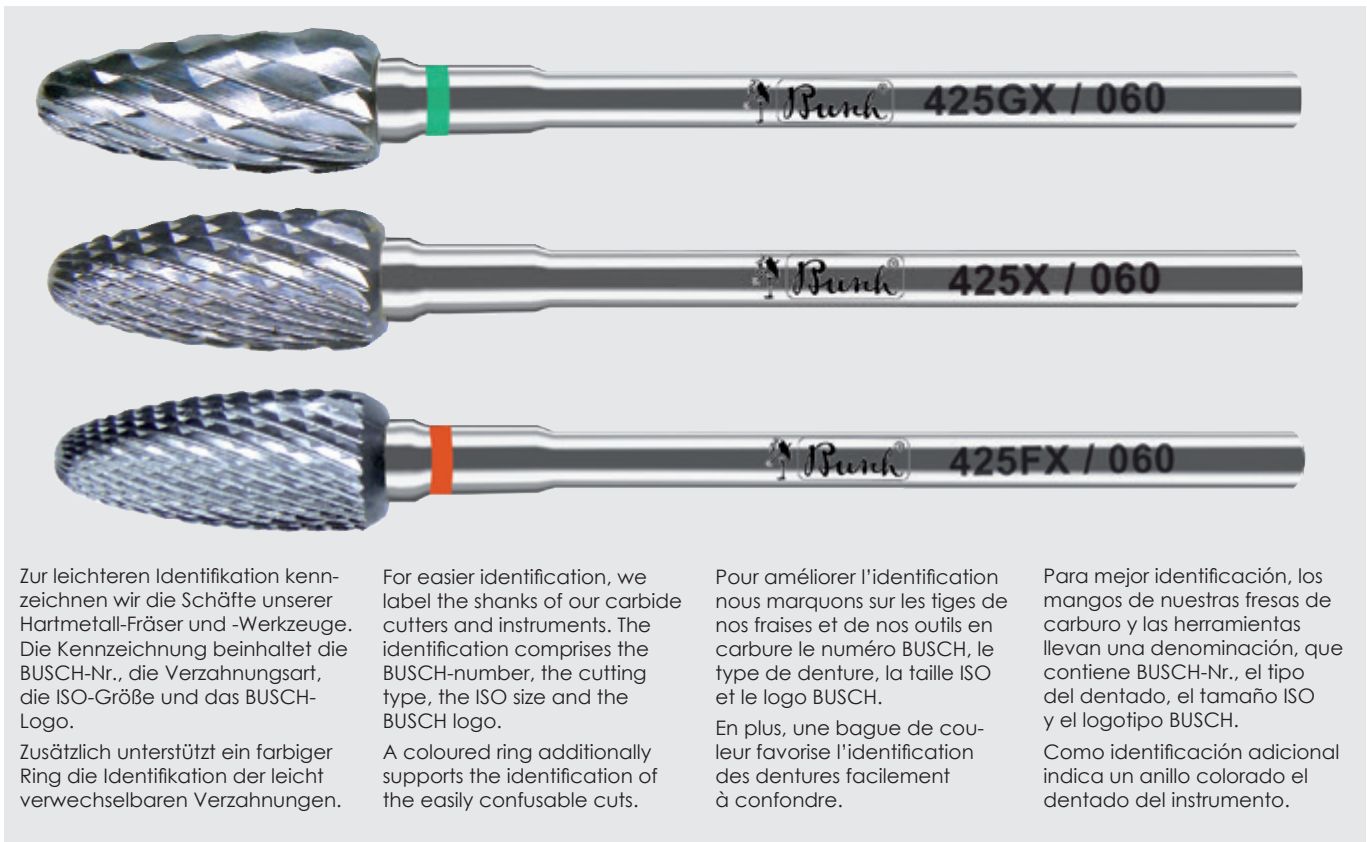

Zur leichteren Identifikation kennzeichnen wir die Schäfte unserer Hartmetall-Fräser und -Werkzeuge. Die Kennzeichnung beinhaltet die BUSCH-Nr., die Verzahnungsart, die ISO-Größe und das BUSCH-Logo.
Zusätzlich unterstützt ein farbiger Ring die Identifikation der leicht verwechselbaren Verzahnungen.

For easier identification, we label the shanks of our carbide cutters and instruments. The identification comprises the BUSCH-number, the cutting type, the ISO size and the BUSCH logo.
A coloured ring additionally supports the identification of the easily confusable cuts.

Pour améliorer l'identification nous marquons sur les tiges de nos fraises et de nos outils en carbure le numéro BUSCH, le type de denture, la taille ISO et le logo BUSCH.
En plus, une bague de couleur favorise l'identification des dentures facilement à confondre.

Para mejor identificación, los mangos de nuestras fresas de carburo y las herramientas llevan una denominación, que contiene BUSCH-Nr., el tipo del dentado, el tamaño ISO y el logotipo BUSCH.
Como identificación adicional indica un anillo colorado el dentado del instrumento.

Hartmetall/carbide/carbure/carburo (ISO 500)

Arbeitsteil
Feinstkorn-Qualität
Schaffmaterial
Hochlegierter Stahl oder Hartmetall
Verbindung Schaff/Arbeitsteil
sofern nicht aus massivem Vollhartmetall, dann geschweißt oder gelötet für höchste Bruchsicherheit
Schleifverfahren
Präzisions-Diamant-Tiefschliff
Schaffdurchmesser
FG, FG x-Ig.:
1,60 mm +0/-0,010 mm
W, W Ig., W x-Ig.:
2,35 mm +0/-0,016 mm
H, H Ig.:
2,35 mm +0/-0,016 mm
Arbeitsteil-Durchmesser
0,3 – 8,0 mm
Rundlaufgenauigkeit
besser als Normen
Normen
DIN, EN, ISO
Max. zul. Umdrehungszahl
auf jeder Packung angegeben
Verzahnungsarten
siehe Kapitaleingangsseiten

working part
finest grain quality
shank material
high alloyed steel or Carbide
connecting shank/working part
unless not out of solid carbide, then welded or soldered for highest security against fracture
grinding method
Diamond precision deep grinding
shank diameters
FG, FG x-Ig.:
1,60 mm +0/-0,010 mm
RA, RA Ig., RA x-Ig.:
2,35 mm +0/-0,016 mm
HP, HP Ig.:
2,35 mm +0/-0,016 mm
working part diameters
0,3 – 8,0 mm
concentricity
superior to standards
standards
DIN, EN, ISO
maximum admissible speed
mentioned on each package
type of cuts
chapter entry pages

partie travaillante
Qualité de grain très fin
matériaux de la tige
Acier fortement allié ou Carbure
joint tige/partie travaillante
si ne pas en carbure massif, alors soudé ou brasé pour une résistance à la rupture maximale
procédé de meulage
Meulage de précision en plongée à l'aide de diamant
diamètres des tiges
FG, FG x-Ig.:
1,60 mm +0/-0,010 mm
CA, CA Ig., RA x-Ig.:
2,35 mm +0/-0,016 mm
PM, PM Ig.:
2,35 mm +0/-0,016 mm
diamètres des parties travaillantes
0,3 – 8,0 mm
concentricité
supérieure aux normes
normes
DIN, EN, ISO
vitesse maximale admissible
indiquées sur chaque boîte
type de denture
pages d'entrée de chapitre

la parte de trabajo
calidad de granos finos
material del mango
acero de alta aleación o de carburo
unión mango/parte de activo
de no ser de carburo puro/ soldada para la mejor resistencia a la rotura
método de amolar
tallado profundo de precisión con diamante
diámetros de los mangos
FG, FG x-Ig.:
1,60 mm +0/-0,010 mm
CA, CA Ig., RA x-Ig.:
2,35 mm +0/-0,016 mm
PM, PM Ig.:
2,35 mm +0/-0,016 mm
diámetros de la parte de fresado
0,3 – 8,0 mm
cocentricidad
Superior a las normas
normas
DIN, EN, ISO
velocidad máxima admitida
indicada en cada caja
tipos de dentado
páginas de entrada de los capítulos

Keramik/ceramic/céramique/cerámica

Arbeitsteil:
 Hochleistungskeramik

Schaftmaterial:
 rostsischerer Stahl
 und Keramik

Schaft-Durchmesser
 H: 2,35 mm +0/-0,016 mm

Arbeitsteil-Durchmesser
 1,4-6,0 mm

Rundlaufgenauigkeit
 besser als Normen

Normen
 DIN, EN, ISO

Max. zul. Umdrehungszahl
 auf jeder Packung angege-
 ben

Verzahnungsarten
 siehe Kapitaleingangsseiten

Nicht geeignet
 für Metalle!

working part:
 high performance ceramic

shank material:
 stainless steel
 and ceramic

shank diameters
 HP: 2,35 mm +0/-0,016 mm

working part diameters
 1,4-6,0 mm

concentricity
 superior to standards

standards
 DIN, EN, ISO

maximum admissible speed
 mentioned on each package

type of cuts
 chapter entry pages

Not suitable
 for metals!

partie travaillante:
 céramique haute performance

mat. de la tige:
 acier inoxydable
 et céramique

diamètres des tiges
 PM: 2,35 mm +0/-0,016 mm

**diamètres des parties
 travaillantes**
 1,4-6,0 mm

concentricité
 Supérieure aux normes

normes
 DIN, EN, ISO

vitesse maximale admissible
 Indiquées sur chaque boîte

type de denture
 pages d'entrée de chapitre

Ne pas utiliser
 pour de métaux!

la parte de trabajo:
 la parte activa cerámica
 de alto rendimiento

mat. d. mango:
 acero inoxidable
 y cerámica

diámetros de los mangos
 PM: 2,35 mm +0/-0,016 mm

diámetro de la parte activa
 1,4-6,0 mm

cocentricidad
 superior a las normas

normas
 DIN, EN, ISO

velocidad máxima admitida
 indicada en cada cajita

tipos de dentado
 páginas de entrada de los
 capítulos

No debe usar estas
 fresas para metales!

Stahl/steel/acier/acero

Material
 ISO 300: Automatenstahl
 ISO 310: Werkzeugstahl
 ISO 311: Werkzeugstahl,
 vernickelt
 ISO 330: Stahl, rostsischer

Härtung
 unter Schutzgas

Schaft-Durchmesser
 FG: 1,60 mm +0/-0,010 mm
 W/Wlg/Wxlg/H:
 2,35 mm +0/-0,016 mm

Arbeitsteil-Durchmesser
 0,5 mm - 12,0 mm

Rundlaufgenauigkeit
 besser als Normen

Normen
 DIN, EN, ISO

Max. zul. Umdrehungszahl
 auf jeder Packung angege-
 ben

Verzahnungsarten
 siehe Kapitaleingangsseiten

material
 ISO 300: free cutting steel
 ISO 310: cold work tool steel
 ISO 311: cold work tool steel,
 nickel plated
 ISO 330: stainless steel

tempering
 with protective gas

shank diameters
 FG: 1,60 mm +0/-0,010 mm
 RA/RAIg/RAXlg/HP:
 2,35 mm +0/-0,016 mm

working part diameters
 0,5 mm - 12,0 mm

concentricity
 Superior to standards

standards
 DIN, EN, ISO

maximum admissible speed
 mentioned on each package

type of cuts
 chapter entry pages

matériau
 ISO 300: acier de décolletage
 rapide
 ISO 310: acier outil
 ISO 311: acier outil, nickelé
 ISO 330: acier inoxydable

trempe
 au gaz protecteur

diamètres des tiges
 FG: 1,60 mm +0/-0,010 mm
 CA/CAIg/CAxlg/PM:
 2,35 mm +0/-0,016 mm

**diamètres des parties
 travaillantes**
 0,5 mm - 12,0 mm

concentricité
 supérieure aux normes

normes
 DIN, EN, ISO

vitesse maximale admissible
 indiquées sur chaque boîte

type de denture
 pages d'entrée de chapitre

material
 ISO 300: acero automático
 ISO 310: acero para
 herramientas
 ISO 311: acero niquelado
 ISO 330: acero inoxidable

temple
 bajo gas de protección

diámetro del mango
 FG: 1,60 mm +0/-0,010 mm
 CA/CAIg/CAxlg/PM:
 2,35 mm +0/-0,016 mm

diámetro de la parte activa
 0,5 mm - 12,0 mm

cocentricidad
 superior a las normas

normas
 DIN, EN, ISO

velocidad máxima admitida
 indicada en cada cajita

tipos de dentado
 páginas de entrada de los
 capítulos



Bush[®]

Drehzahlempfehlungen Polierer und Bürsten
recommended r.p.m. polishers and brushes
recommandations de vitesse polissoirs et brosses
recomendaciones de velocidad pulidores y cepillos

Zahnmedizin/dentistry/odontologie/odontología

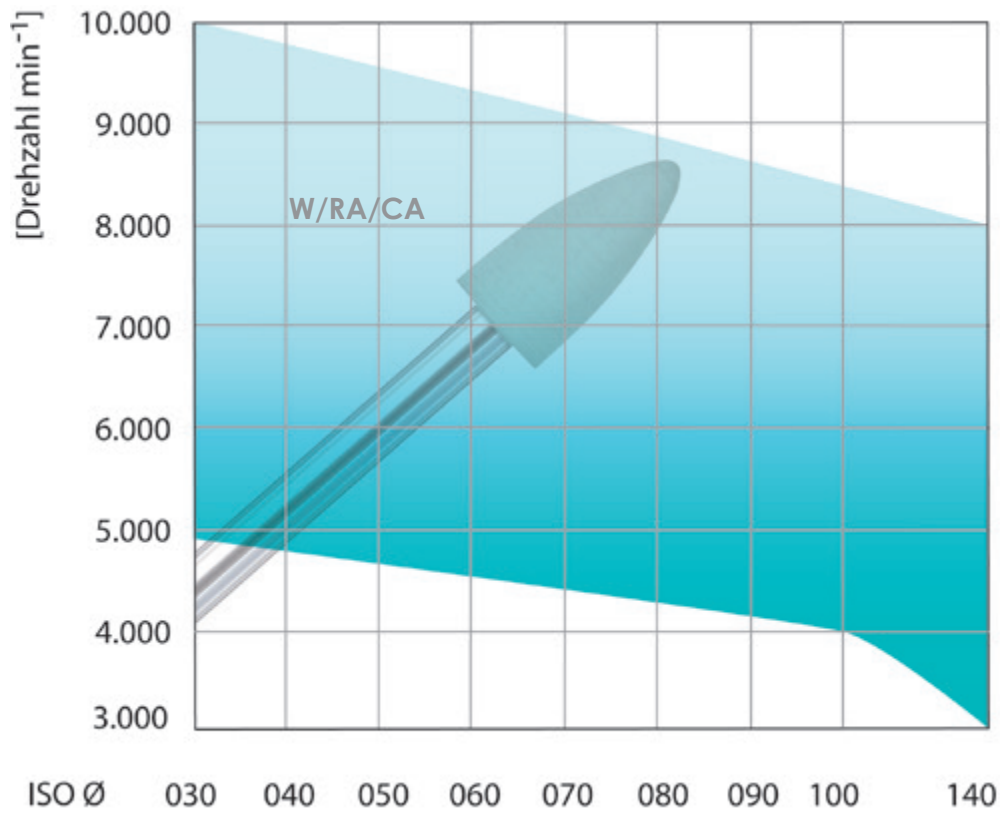

(FG Ø030: 3.000–8.000 min⁻¹)
mit Wasserkühlung.
Bei unzureichender Wasserkühlung kann es zu irreversiblen Schädigungen des Zahnes und des umliegenden Gewebes kommen.

(FG Ø030: 3.000–8.000 min⁻¹)
with water spray.
If not sufficient cooling medium is used, irreversible damages of the teeth and the surrounding tissue can happen.

(FG Ø030: 3.000–8.000 min⁻¹)
avec refroidissement à l'eau.
En cas d'un refroidissement à l'eau insuffisant les dents ainsi que les gencives peuvent être nuis d'une façon irréversible.

(FGØ030: 3.000–8.000 min⁻¹)
con refrigeración del spray (agua).
En caso de refrigeración con agua insuficiente podría causar daños irreversibles en los dientes y alrededor del tejido/encia.

Zahntechnik/dental technique/prothèse dentaire/protesis dental

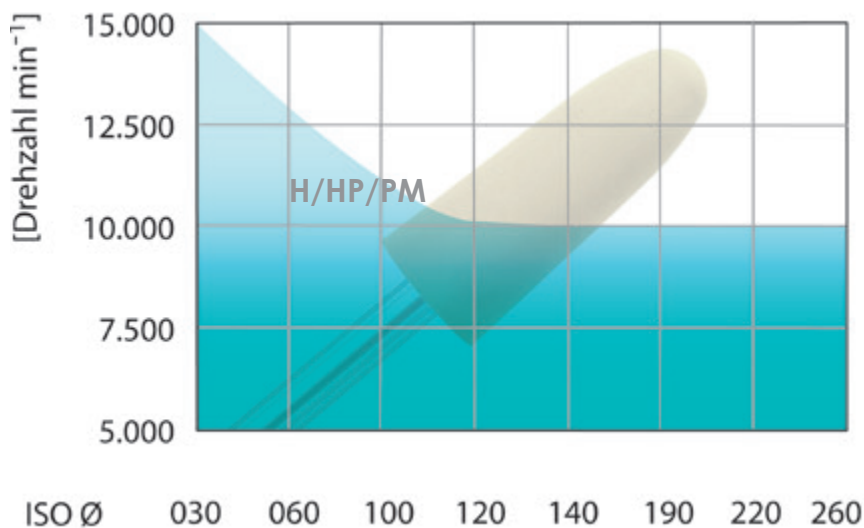

Drehzahlempfehlungen Schleifkörper
 recommended r.p.m. abrasives
 recommandations de vitesse abrasives
 recomendaciones de velocidad abrasivos

Zahnmedizin/dentistry/odontologie/odontología

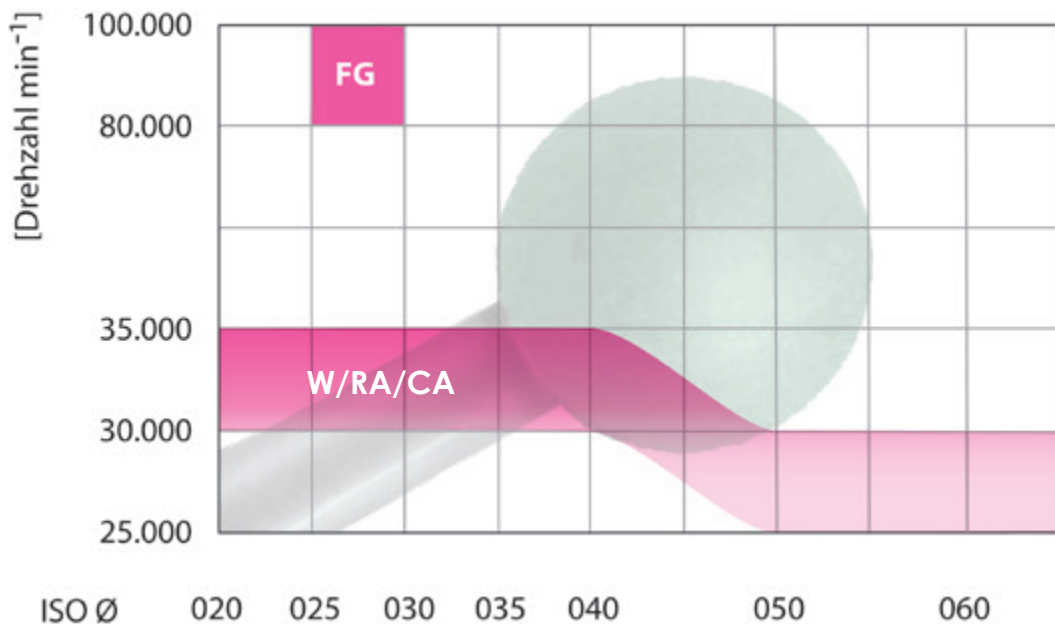



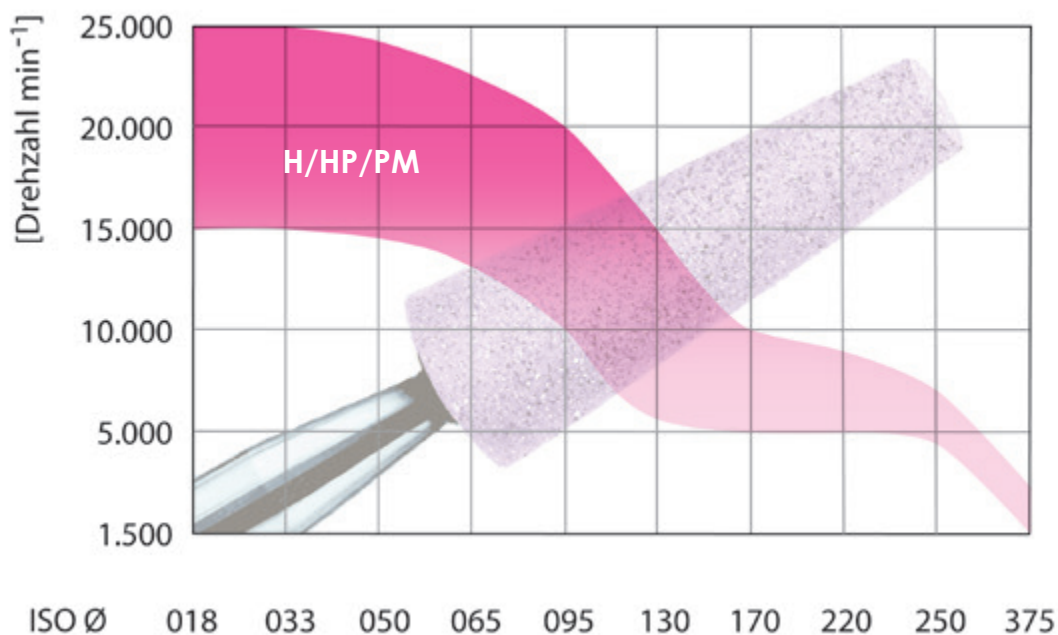

Zahntechnik/dental technique/prothèse dentaire/protesis dental

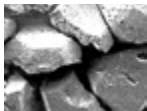

Diamantdurchsetzte Schleifkörper
 diamond interspersed abrasives
 abrasifs imprégnés de diamant
 abrasivos impregnado de diamante

040-120: 8.000-12.000 min⁻¹
 040-120: 8.000-12.000 r.p.m.
 040-120: 8.000-12.000 min⁻¹
 040-120: 8.000-12.000 min⁻¹

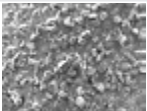
Diamant Körnung Zahnmedizin/diamond grit dentistry/diamantés grain odontologie/
diamantados grano odontologia

Körnung grit grain grano	R.E.M. (30x) D.S.M. (30x) M.E.B. (30x) M.E.R. (30x)	*) Korngröße (µm), Mittelwert *) grit size (µm), mean value *) taille de grain (µm), valeur moyenne *) tamaño de grano (µm), valor medio	ISO-Nr. ISO-No. ISO-No. ISO-No.	Farbkennzeichnung color code code couleurs marcado de colores	Anwendung application application aplicación
sehr grob very coarse très gros muy grueso		181	544	schwarzer Ring ● black ring bague noire anillo negro	zügiges Vorschleifen quick pregrinding dégrossissage rapide tallado inicial rápido
grob coarse gros grueso		151	534	grüner Ring ● green ring bague verte anillo verde	Vorschleifen pregrinding dégrossissage tallado inicial
mittel medium moyen medio		107	524	ohne Ring without ring sans bague sin anillo	Formschleifen shape grinding façonnage rectificado de forma
fein fine fin fino		46	514	roter Ring ● red ring bague rouge anillo rojo	Feinschleifen fine grinding abrasion de précision rectificado fino
extra fein extra fine extra fin extra fino		25	504	gelber Ring ● yellow ring bague jaune anillo amarillo	Finieren finishing finition acabado

Diamant Körnung Zahntechnik/diamond grit dental technique/diamantés grain prothèse dentaire/
diamantados grano protesis dental

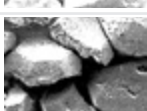
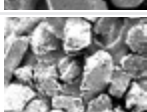
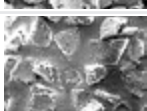
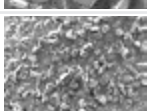
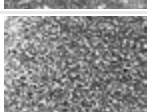
Körnung grit grain grano	R.E.M. (30x) D.S.M. (30x) M.E.B. (30x) M.E.R. (30x)	*) Korngröße (µm), Mittelwert *) grit size (µm), mean value *) taille de grain (µm), valeur moyenne *) tamaño de grano (µm), valor medio	ISO-Nr. ISO-No. ISO-No. ISO-No.	Farbkennzeichnung color code code couleurs marcado de colores	Anwendung application application aplicación
mega grob mega coarse mega gros hiper grueso		500	-	2 schwarze Ringe ●● 2 black rings 2 bagues noire 2 anillos negros	zügiges Vorschleifen quick pregrinding dégrossissage rapide rectificado inicial rápido
super grob super coarse super gros super grueso		300	-	schwarzer Ring ● black ring bague noire anillo negro	Vorschleifen pregrinding dégrossissage rectificado inicial
grob coarse gros grueso		151	534	grüner Ring ● green ring bague verte anillo verde	Vorschleifen pregrinding dégrossissage rectificado inicial
mittel medium moyen medio		107	524	ohne Ring without ring sans bague sin anillo	Formschleifen shape grinding façonnage rectificado de forma
fein fine fin fino		46	514	roter Ring ● red ring bague rouge anillo rojo	Feinschleifen fine grinding abrasion de précision rectificado fino
extra fein extra fine extra fin extra fino		25	504	gelber Ring ● yellow ring bague jaune anillo amarillo	Finieren finishing finition acabado

ZIRAMANT Körnung zur Bearbeitung von Zirkonoxid in der Zahnmedizin

ZIRAMANT grit for work on zirconia in dentistry

Grain ZIRAMANT pour le traitement de l'oxyde de zirconium dans l'ontologie

Grano ZIRAMANT para el tratamiento de circonio (ZrO₂) en la odontología

Körnung grit grain grano	R.E.M. (30x) D.S.M. (30x) M.E.B. (30x) M.E.R. (30x)	*) Korngröße (µm), Mittelwert *) grit size (µm), mean value *) taille de grain (µm), valeur moyenne *) tamaño de grano (µm), valor medio	ISO-Nr. ISO-No. ISO-No. ISO-No.	Farbkennzeichnung color code code couleurs marcado de colores	Anwendung application application aplicación
grob coarse gros grueso		91 – 151	535	2 Ringe ●● 1 blauer + 1 grüner 2 rings 1 blue + 1 green 2 bagues 1 bleue + 1 verte 2 anillos 1 azul + 1 verde	Trepanieren, Entfernen von Zirkonoxid trepaning removal of zirconium oxide trépanation, retrait de l'oxyde de zirconium trépanación, eliminación del óxido de circonio
mittel medium moyen medio		91 – 126	525	2 blaue Ringe ●● 2 blue rings 2 bagues bleues 2 anillos azules	Korrektur von Zirkonoxid corrections of zirconium oxide correction de l'oxyde de zirconium retoque del óxido de circonio
fein fine fin fino		40 – 60	515	2 rote Ringe ●● 2 red rings 2 bagues rouges 2 anillo rojos	Feinkorrektur von Zirkonoxid fine corrections of zirconium oxide correction de précision de l'oxyde de zirconium retoques precisos del óxido de circonio

ZIRAMANT Körnung zur Bearbeitung von Zirkonoxid in der Zahntechnik mit Laborturbine

ZIRAMANT grit for work on zirconia in dental technique with laboratory turbine

Grain ZIRAMANT pour le traitement de l'oxyde de zirconium avec turbine laboratoire pour les prothèses dentaires

Grano ZIRAMANT para el tratamiento de óxido de circonio con la turbina de uso en laboratorios dentales

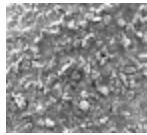
Körnung grit grain grano	R.E.M. (30x) D.S.M. (30x) M.E.B. (30x) M.E.R. (30x)	*) Korngröße (µm), Mittelwert *) grit size (µm), mean value *) taille de grain (µm), valeur moyenne *) tamaño de grano (µm), valor medio	ISO-Nr. ISO-No. ISO-No. ISO-No.	Farbkennzeichnung color code code couleurs marcado de colores	Anwendung application application aplicación
grob coarse gros grueso		107 – 151	535	2 Ringe ●● 1 grüner + 1 schwarzer 2 rings 1 green + 1 black 2 bagues 1 verte + 1 noire 2 anillos 1 verde + 1 negro	Punktförmiges, flächiges Ausschleifen grinding individual points and larger areas abrasion ponctuelle et de surfaces lisado en punta y bidimensional
fein fine fin fino		40 – 60	515	2 rote Ringe ●● 2 red rings 2 bagues rouges 2 anillos rojos	Feinstbearbeitung von Zirkonoxid finest work on zirconium oxide traitement de précision de l'oxyde de zirconium tratamientos precisos de óxido de circonio

*) Die Korngröße ist optimal abgestimmt auf übliche Anwendungsgebiete, Umdrehungszahlen, Formen und Größen der Diamantschleifer und kann im Mittelwert bei einzelnen Instrumenten abweichen.

*) Most favourable grit size for the usual applications, speed and as well as for sizes and shapes of the diamond instruments may differ from the mean value of individual instruments.

*) La taille de grain est adaptée de façon optimale aux différentes applications, vitesses de rotation, formes et diamètres des instruments diamantés, et peut différer de la moyenne dans le cas de certains instruments.

*) El tamaño de grano está adaptado, de manera óptima, a las aplicaciones, velocidades, formas y diámetros de los instrumentos diamantados y su valor medio puede diferir en algunos instrumentos en particular.

ZAHNMEDIZIN
DENTISTRY
ODONTOLOGIE
ODONTOLOGIA

Diamant

COOL DIAMANT

CD03	9
CD06	9
CD09	9
CD12	9
CD15	9
CD18/CD18G	9
CD19/CD19G	9
CD21/CD21G	11
CD24/CD24G	11
CD25/CD25G	11
CD27/CD27G	11
CD30/CD30G	11
CD33/CD33G/CD33F	11
CD34/CD34G	11
CD36	12
CD37	12
CD39/CD39G	12
CD42/CD42G	12
CD45	12
CD48/CD48G	12
CD51/CD51G	12
CD54/CD54G	13
CD55/CD55G/CD55F	13
CD57	13
CD60/CD60G/CD60F	13
CD61/CD61G/CD61F	13
CD63	10
CD66/CD66G/CD66F	10
CD69/CD69G/CD69F	10
CD72/CD72G/CD72F	10
CD78/CD78G	13
CD80/CD80G/CD80F	13

sehr grobe Körnung

very coarse grit

grain très gros

grano muy grueso

5368	29
5379	29
5801	15
5811	29
5831	16
5836	18
5837	18
5848	24
5850	26
5856	26
5862	28
5863	28
5878	19
5878K	25
5879	19
5879K	25
5881	21
5909	31

grobe Körnung

coarse grit

grain gros

grano grueso

6368	29
6379	29
6801	15
6801L	15
6802	15
6805	16

6806	16
6830	16
6831	16
6831R	16
6835	18
6836KR	17
6836	18
6837KR	17
6837	18
6838	21
6846	24
6847	24
6847KR	22
6848	24
6848KR	22
6850	26
6852	27
6855	26
6856	26
6858	27
6859	27
6862	28
6863	28
6877	19
6878	19
6878K	25
6879	19
6879K	25
6880	21
6881	21
6882	21
6889	29
6909	31

mittlere Körnung

medium grit

grain moyen

grano mediano

368	29
379	29
390	29
801	15
801L	15
802	15
805	16
806	16
807	16
811	29
813	31
818	31
830	16
831	16
831R	16
833A	31
834	31
835	18
835KR	17
836	18
836KR	17
837	18
837L	18
837LKR	17
837KR	17
838	21
839	30
842	18
842KR	17
845	24
845KR	22
846	24
846KR	22
CI846	23
847	24
CI847	23
847KR	22

848	24
848KR	22
850	26
851	30
852	27
855	26
856	26
857	30
858	27
859	27
860	28
861	28
862	28
863	28
864	28
876	19
877	19
877K	25
878	19
878K	25
879	19
879K	25
879L	19
880	21
881	21
882	21
885	20
886	20
889	29
899	29
908	31
909	31
MI 801	33
MI 802	33
MI 806	33
MI 830	33
MI 838	33
MI 889	33

feine Körnung

fine grit

grain fins

grano fino

8801	15
8368	29
8390	29
8379	29
8392	30
8406LF	35
8407LF	35
8830	16
8831	16
8831R	16
8835	18
8835KR	17
8836	18
8836KR	17
8837	18
8837LKR	17
8837KR	17
8838	21
8845KR	22
8846	24
8846KR	22
8847	24
8847KR	22
8848	24
8848KR	22
8850	26
8852	27
8855	26
8856	26
8858	27
8859	27
8860	28

8861	28
8862	28
8863	28
8863GK	30
8864	28
8876	19
8877	19
8877K	25
8878	19
8878K	25
8879	19
8879L	19
8879K	25
8880	21
8881	21
8882	21
8886	20
8889	29
8899	29
MI 8802	33
MI 8806	33
MI 8830	33
MI 8838	33
MI 8889	33

x-fein Körnung

x-fine grit

grain x-fin

grano x-fino

368EF	29
379EF	29
390EF	29
801EF	15
835KREF	17
836KREF	17
837KREF	17
845KREF	22
846KREF	22
CI846EF	23
CI847EF	23
847KREF	22
852EF	27
856EF	26
858EF	27
859EF	27
860EF	28
862EF	28
863EF	28
863GKEF	30
878EF	19
879EF	19
881EF	21
957EF	30
8406LEF	35
8407LEF	35

ZIRAMANT

379Z	34
855Z	34
862Z	34
6801Z	34
6831RZ	34
6855Z	34
6880Z	34
8801LZ	34
8838LZ	34

**Hartmetall / Carbide
Carbure / Carburo**

Kavitäten- und Fissurenbohrer
Excavating and fissure burs
Fraises carbure pour cavités et
fraises à fissures
Fresas de carburo excavado-
ras y fisuras

1	40
1S	40
1SX	39
1SXM	39
2	40
7	41
21	41
21L	41
21R	41
23	42
23L	42
23R	42
23SR	42
25R	41
31	41
31L	42
31R	42
32HG	43
33	43
33L	43
33R	43
59	42
207	43
400LRA	43

Kronentrenner
Crown cutters
Fraises coupes-couronnes
Fresas corta-coronas

21RX	46
23RX	46
34	46
34D	45
36R	46
36RD	45
36RDL	45
38R	46
38RD	45
38RDL	45
6855Z	45
6880Z	45

Finierer
Finishing burs
Fraises à finir
Fresas para acabar

41	47
41F	50
44E	47
44E-F	50
44E-UF	51
45	47
45F	50
45UF	51
46	47
47L	47
48	47
48F	50
48L	47
48LF	50
48L-UF	51
50	48
243	49
243K	49
243KR	49
244	49

244K	49
244KR	49
245	49
245K	49
332	48
333	48
334	48
334F	50
334UF	51
335	48
335F	50
335UF	51
375R	49
448	48

LongLife PERIO-PRO

406	52
406L	52
407	52
407L	52

Chirurgie-Instrumente
Surgical instruments
Instruments chirurgicaux
Fresas la cirugía,

1S	53
31RL	55
33RL	55
141	53
141A	53
161	54
162	54
166	54
267	55
269	55
700XXL	55

Knochenfräser
Bone cutters
Fraises à os
Fresas para huesos

162A	54
164LA	54
166A	54

Endo Erweiterer
Endo reamer
Endo élargisseurs
Endo (ampliación del canal)
152Z

152Z	55
------	----

**Stahl / Steel
Acier / Acero**

Kavitäten-Bohrer
Excavating burs
Fraises pour cavités
Fresas excavadoras

1	59
2	59
38	59

Finierer
Plug finishing burs
Fraises à finir
Fresas de acabar

41	60
47	60
48	60

Chirurgie-Instrumente
Surgical instruments
Instruments chirurgicaux
Instrumentos quirúrgicos

1RS	61
161RS	61
162RS	61
166RS	61
167RS	61

Prophylaxe-Instrumente
Prophylaxis instruments
Instruments prophylactiques
Instrumentos profilácticos

401	60
402	60
403	60
404	60

**Polierer / Polishers /
Polissoirs / Pulidores**

9577	65
9578	65
9579	65
9581	65
9583	65
9578	65
9588	65
9589	65
9591	65
9593	65
9604	67
9607	67
9608	67
9609	67
9607G	64
9608G	64
9609G	64
9611	67
9617	67
9618	67
9619	67
9621	67
9631	72
9633S	72
9635	73
9635H	73
9635S	73
9650	72
9667	66
9668	66
9669	66
9677	66
9678	66
9679	66
9730	73
9730H	73
9730S	73
9731	73
9731H	73
9731S	73
9735SiC	70
9730SiC	70
9731SiC	70
9807	68
9808	68
9809	68
9811	68
9817	68
9818	68
9819	68
9821	68
9907	69

9908	69
9909	69
9911	69
9917	69
9918	69
9919	69
9921	69

Soft Disc

9590G	71
9590M	71
9590F	71
9590EF	71
312RS	71
9590/100 Set	71
9590/140 Set	71

**Schleifkörper / Abrasives
Abrasisifs / Abrasivos**

grün/green/vert/verde

601	76
602	76
603	76
619	76
622	76
626	76
627	76
637	76
648	76
649	76
661	76
662	76
666	76
667	76
671	76

Arkansas
weiss/white/blanc/blanco

601	77
638	77
649	77
653	77
661	77

ZAHNTECHNIK		893.....	.89	8838LZ.....	.91	426MQS.....	108
DENTAL TECHNIQUE		894.....	.89	8855Z.....	.91	426SGX.....	105
PROTHESE DENTAIRE		909.....	.88	8860Z.....	.91	426X.....	110+111
PROTESIS DENTAL						427.....	108
Diamant		feine Körnung		Hartmetall		427FX.....	111
mega grobe Körnung		8368.....	.87	Carbide		427X.....	110
mega coarse grit		8390.....	.87	Carbure		428.....	108
grain mega gros		8850.....	.86	Carburo		428FX.....	111
grano hiper grueso		8854.....	.85	Kavitäten- und Fissurenbohrer		428X.....	110+111
DT4854R.....		8854R.....	.85	Excavating and fissure burs		429.....	108
DT4880.....		8858.....	.86	Fraises carbure pour cavités et		429FFX.....	112
super grobe Körnung		8859.....	.87	fraises à fissures		429FX.....	111+112
super coarse grit		8860.....	.87	Fresas de carburo excavado-		429G.....	107
grain extra gros		8863.....	.87	ras y fisuras		429GX.....	106
grano super grueso		8893.....	.89	1.....		429GXA.....	107
5369.....		8894.....	.89	1SXM.....		429MQS.....	108
5405.....		x-fein Körnung		2.....		429SGX.....	105
DT5854R.....		x-fine grit		3.....		429SGXA.....	106
DT5880.....		grain x-fin		21.....		429X.....	110+112
5893.....		grano x-fino		21L.....		429XTi.....	109
5894.....		390EF.....	.87	21R.....		431FX.....	111
grobe Körnung		850EF.....	.86	23.....		431X.....	111
coarse grit		858EF.....	.86	23L.....		432.....	109
grain gros		863EF.....	.87	23R.....		432FX.....	111
grano grueso		893EF.....	.89	23SR.....		432X.....	111
6850.....		Diamantscheiben		23SRF.....		433.....	109
6854.....		Diamond Discs		23SRX.....		433FFX.....	112
6854R.....		Disques diamantés		31.....		433FX.....	111
6862.....		Discos diamantados		31L.....		433MQS.....	108
6863.....		902.....	.93	31R.....		433X.....	110+111
6863.....		910.....	.93	33.....		515.....	109
6893.....		911.....	.93	33L.....		Laborfräser, klein	
6894.....		911H.....	.92	33R.....		Cutters, small	
mittlere Körnung		911HH.....	.92	41.....		Carbure, petit	
medium grit		911H.....	.92	45.....		Carburo, pequeño	
grain moyen		911S.....	.93	231.....		MIDIS	
grano mediano		911PS.....	.93	Laborfräser, groß		M426FFX.....	115
368.....		916.....	.93	Cutters, large		M426FX.....	115
369.....		918PB.....	.93	Carbure, grand		M426FXK.....	114
379.....		919P.....	.93	Carburo, grueso		M426GQSR.....	113
390.....		943.....	.92	421.....		M426MQS.....	114
801.....		7911.....	.92	421GQSR.....		M426X.....	115
805.....		7912.....	.92	421X.....		M426XTi.....	114
807.....		LONGLIFE-		423FX.....		M428FFX.....	115
812.....		- Sinter Diamant-Schleifer		423X.....		M428FX.....	115
818.....		- Sintered Diam. Instruments		424.....		M428FXK.....	114
825.....		- Diamant dans la masse		424FX.....		M428MQS.....	114
830.....		- Instrumentos diamantados		424G.....		M428X.....	115
835.....		1351.....	.94	424GQSR.....		M428XTi.....	114
836.....		1837.....	.95	424GX.....		M433FFX.....	115
837.....		1850.....	.94	424MQS.....		M433FX.....	115
842.....		1881.....	.95	424SGX.....		M433FXK.....	114
845.....		1893.....	.95	424X.....		M433GQSR.....	113
846.....		1941.....	.95	425.....		M433MQS.....	114
847.....		3351.....	.94	425FFX.....		M433X.....	115
848.....		3368.....	.94	425FX.....		M433XTi.....	114
849.....		3818.....	.94	425G.....		SHORTIES	
850.....		3850.....	.94	425GQRS.....		S420FFX.....	118
852.....		3859.....	.94	425GX.....		S420FX.....	117
854.....		ZIRAMANT		425GXA.....		S421FX.....	117
854R.....		6379Z.....	.91	425MQS.....		S421X.....	116
855.....		6801LZ.....	.90	425SG.....		S422FFX.....	118
856.....		6838LZ.....	.90	425SGX.....		S422FX.....	117
858.....		6855Z.....	.91	425SGXA.....		S422X.....	116
859.....		6860Z.....	.91	425X.....		S423FFX.....	118
860.....		8379Z.....	.91	426.....		S423FX.....	117
862.....				426FFX.....		S423MQS.....	116
863.....				426FX.....		S423X.....	116
880.....				426GQSR.....		S423XTi.....	116
				426GX.....		S426FFX.....	118

Inhalt / Index / Index / Indice

S426FX	117
S426X	117
S427FFX	118
S427FX	117
S427MQS	116
S427X	117
S428FFX	118
S428FX	117
S428FXK	116
S428X	117
S428XTi	116
S430FX	118
S430X	117
S431FX	118
S431X	117
S433FFX	118
S433FX	118
S433X	117
S433XTi	116

Linkshänder-Fräser
Left-handed cutters
Fraise pour gaucher
Fresa para zurdos

425FX060L	112
429FX045L	112
429FX060L	112
425X060L	112
429X045L	112
429X060L	112

Hartmetallwerkzeuge
für die Frästechnik
Carbide tools for Milling technique
Instruments carbure pour technique de fraisage
Instrumentos de carburo para la técnica de fresado

1	122
21XL	122
294	123
296X	123
408	121
408FX	120
408H	121
408R	121
408RFX	120
408RH	121
408RX	120
408X	120
410	121
410R	121
410RFX	120
410RH	121
410RX	120
410X	120
444FR	119
445FR	119
445SR	119
4203S	122

Keramik

Céramic

Ceramique

Cerámica

Fräser für Kunststoffe und Zirkonoxid-Weißlinge
Cutters for acrylics and pre-sintered zirconia
Fraises pour la résine et la zircone non frittée
Fresas para resinas y dióxido de zirconio presinterizado

K423FX	127
K424GQSR	127
K425GQSR	127
K429GQSR	127
K432GQSR	127
K433GQSR	127
K424X	127
K425X	127
K426X	127
K429X	127
K432X	127
K433X	127

Stahl

Steel

Acier

Acero

Kavitäten-Bohrer
Excavating burs
Fraises pour cavités
Fresas excavadoras

1	131
2	131
3	131
36	132
38	132

Finierer
Finishing burs
Fraises à finir
Fresas de acabar

41	132
48	132

Fräser für Kunststoff und Gips
Cutters for acrylic and plaster
Fraises pour résine et plâtre
Fresas para resina y yeso

71	133
72	133
75	133
76	133
77	133
78	133
79	133
81	134
82	134
85	134

Spezial-Instrumente
Special instruments
Instruments spéciaux
Instrumentos especiales

203	135
-----	-----

219	135
452S	135
452RS	135

Träger (ZM + ZT)

Mandrels (ZM + ZT)

Mandrins (ZM + ZT)

Mandriles (ZM + ZT)

301LRS	136
303	136,160
303RS	136,160
305RS	136,160
312RS	136
313RS	137
314RS	137
315RS	137
316RS	137
318RS	137
324RS	136
329	136

Polierer

Polishers

Polissoirs

Pulidores

9602	141
9603	141
9605	141
9602G	140
9603G	140
9612	141
9613	141
9615	141
9622	147
9624	147
9626	146
9628	146
9626G	146
9628G	146
9660	140
9690G	143
9690M	143
9702	141
9704	141
9706	141
9702G	140
9706G	140
9712	141
9716	141
9800	142
9852	145
9853	145
9854	145
9855	145
9856	145
9862	145
9863	145
9864	145
9865	145
9866	145
9952	144
9953	144
9954	144
9955	144
9956	144
9962	144
9963	144
9964	144
9965	144
9966	144

Bürsten, Schwabbel
Brushes, polishing buffs
Brosses, Disques à polir
Cepillos, Discos pulidores

9544M	147
9544F	147
9636	149
9638	149
9641	148
9642	148
9643	148
9646	148
9644	148
9736	149
9738	149

Schleifkörper

Abrasives

Abrasifs

Abrasivos

D702	152
D712	152
D722	152
D723	152
D733	152
D732	152

grün/green/vert/verde

601	153
602	153
613	153
622	153
628	153
632	153
633	153
637	153
639	153
649	153
661	153
662	153
665	153
671	153
731	153
732	153
733	153
734	153
743	153
744	153
798	158
CP613	152
CP649R	152
CP652R	152
CP671	152
CP732	152
CP728	152

rosa/pink/rose/rosa

601	154
602	154
603	154
609	154
613	154
619	154
620	154
623	154
624	154
627	154

ZAHNTECHNIK
DENTAL TECHNIQUE
PROTHESE DENTAIRE
PROTESIS DENTAL

Schleifkörper

Abrasives

Abrasifs

Abrasivos

632	154	weiss/white/blanc/blanco	
633	154	768	159
636	154	blau/blue/bleu/azul	
637	154	B601	154
638	154	B649R	154
639	154	B652R	154
640	154	B671	154
646	154	B732	154
648	154		
649	154		
650	155		
651	155		
652	155		
656	155		
657	155		
658	155		
661	155		
662	155	Trennscheiben	
663	155	Separating discs	
665	155	Disques à separer	
666	155	Discos de separados	
667	155	braun/brown/marron/marrón	
671	155	438	160
677	155	438D	161
682	155	438T	160
701	155		
703	155		
711	155	Hitzlos Schleifräder	
712	155	Hitzlos abrasive wheels	
716	155	Hitzlos meules abrasives	
721	155	Hitzlos ruedas abrasivas	
722	155	761	156
731	155	762	156
732	155	766	156
733	155	767	156
743	155	771	156
744	155	772	156
749	155	773	156
755	155	776	156
760	155	777	156
767	158	778	156
772	158	782	156
777	158	783	156

Silent Schleifräder
Silent abrasive wheels
Silent meules abrasives
Silent ruedas abrasivas

761	157
762	157
766	157
767	157
768	157
771	157
772	157
773	157
776	157
777	157

Set, Bohrerständer,

Sonstiges

Set, Bur bloc,

Miscellaneous

Set, Porte-fraises, Autres

Set, Fresero, Otros

Zirkon Workflow Set	164,165
STERI-SAFEpro 5772+D	166
STERI-SAFEwave 5773	167-170
5762	171
5764	171
5780	171
442	172
443	172
990	172
440	173
441	173
599	173

Basisinformationen

Basic information

Informations de base

Informaciones básicas

. 178-189

Index US-No

Dentistry

Carbide

Excavating . . . and fissure burs

2SXM	39
3SXM	39
4SXM	39
5SXM	39
6SXM	39
7SXM	39
8SXM	39
10SXM	39
1SX	39
2SX	39
3SX	39
4SX	39
5SX	39
6SX	39
7SX	39
8SX	39
10SX	39
2S	40
3S	40
4S	40
5S	40
6S	40
7S	40
8S	40
10S	40
¼	40
½	40
¾	40
1	40
1½	40
2	40
3	40
4	40
5	40
6	40
7	40
8	40
9	40
10	40
33½	40
34	40
34½	40
35	40
36	40
37	40
38	40
330	41
331	41
332	41
333	41
55	41
56	41
57	41
58	41
59	41
60	41
1157	41
1158	41
1159	41
57L	41

58L	41
555	41
557	41
558	41
559	41
560	41
1557	42
1558	42
1559	42
557L	42
558L	42
168	42
170	42
171	42
1170	42
1171	42
1172	42
170L	42
171L	42
699	43
700	43
701	43
702	43
1700	43
1701	43
699L	43
700L	43
701L	43
702L	43
958	43
7004	47
7005	47
7006	47
7008	47
7009	47
7102	47
7104	47
7106	47
7108	47
7303	47
7304	47
7675	49
7686	49

Surgical instruments

2S	53
4S	53
6S	53
8S	53
10S	53
557X	55
558X	55
701X	55
702X	55
703X	55

Steel

Excavating burs	
¼	59
½	59
1	59
1½	59
2	59
3	59
4	59
5	59

6	59
7	59
8	59
9	59
10	59
11	59
33½	59
35	59
700	59
701	59
702	59
703	59
Finishing burs	
7002	60
7004	60
7005	60
7006	60
7006	60
7008	60
242	60
Surgical burs	
¼RS	61
1½Rs	61
2RS	61
3RS	61
4RS	61
5RS	61
6RS	61
7RS	61
8RS	61
Dental technique	
Carbide	
Burs	
¼	101
½	101
¾	101
1	101
1½	101
2	101
3	101
4	101
5	101
6	101
7	101
8	101
10	101
1SXM	101
3SXM	101
4SXM	101
5SXM	101
6SXM	101
7SXM	101
8SXM	101
33½	101
34	101
34½	101
35	101
36	101
37	101
38	101
39	101
41	101
14	101
55	102
56	102
57	102
58	102
59	102
60	102

61	102
62	102
63	102
1157	102
1158	102
1159	102
57L	102
58L	102
59L	102
555	102
556	102
557	102
558	102
559	102
560	102
561	102
562	102
563	102
1556	102
1557	102
1558	102
1559	102
1560	102
1561	102
557L	102
558L	102
Excavating, fissure burs, finishing burs	
168	103
169	103
170	103
171	103
172	103
1168	103
1170	103
1171	103
1172	103
170L	103
171L	103
698	104
699	104
700	104
701	104
702	104
703	104
704	104
1700	104
1701	104
1702	104
1703	104
700L	104
701L	104
702L	104
7004	104
Steel	
burs	
¼	131
½	131
¾	131
1	131
1½	131
2	131
3	131
4	131
5	131
6	131
7	131
8	131
9	131
10	131
11	131
19	131
20	131
33½	131
34	131
34½	131
35	131
36	131
37	131
38	131

Abbildungen und Fotos sind urheberrechtlich geschützt. Nachdruck oder Reproduktionen in irgendwelcher Form, auch auszugsweise, sind nur mit schriftlicher Genehmigung der BUSCH & CO. GmbH & Co. KG Engelskirchen, gestattet. Programm- und Konstruktionsänderungen im Sinne des Fortschrittes sind Tradition des Hauses und bleiben vorbehalten.

Illustrations and photos are protected by copyright. Reproductions, also by extract in any form, are only permitted with written authorization of BUSCH & CO. GmbH & Co. KG Engelskirchen. To reserve the right to modify our range of products and their design in the sense of progress are traditions of our company.

Les illustrations et photos sont protégés par le droit de l'auteur. Toutes sortes de reproductions, même partielles sont seulement permises avec l'autorisation écrite de la société BUSCH & CO. GmbH & Co. KG Engelskirchen. Nous nous réservons le droit aux modifications du programme et de la construction dans le sens du progrès qui sont la tradition de notre société.

Ilustraciones y fotografías protegidas por el derecho del autor. Reproducción también en extracto sólo se permite con la autorización escrita de la compañía BUSCH & CO. GmbH & Co. KG Engelskirchen. Las variaciones que respecten el programa y el diseño en el sentido del progreso son tradición de nuestra empresa y quedan reservadas.



BUSCH & CO. GmbH & Co. KG

Postfach 1152
D-51751 Engelskirchen

Unterkaltenbach 17-27
D-51766 Engelskirchen
GERMANY

Telefon: +49 (0) 2263 86-0
Telefax: +49 (0) 2263 20741
mail@busch.eu
www.busch.eu